

# Charleston Area Regional Transportation Authority (CARTA)



## 40-Foot Electric Bus Request For Proposals

Charleston, South Carolina  
Date: November 21, 2019

---

**Due Date:** January 03, 2020  
**Time:** 3:00 P.M. EST

**Receipt Location:**  
BCD Council of Governments  
Attn: Jason McGarry  
5790 Casper Padgett Way  
North Charleston, SC 29406

# Contents

<b>SECTION 1: NOTICE OF REQUEST FOR PROPOSALS</b> .....	<b>11</b>
<b>NR 1. Description of the Work to be Done</b> .....	<b>11</b>
<b>NR 2. Obtaining Proposal Documents</b> .....	<b>11</b>
<b>NR 3. Proposal Due Date and Submittal Requirements</b> .....	<b>11</b>
<b>NR 4. Validity of Proposals</b> .....	<b>11</b>
<b>SECTION 2: INSTRUCTIONS TO PROPOSERS</b> .....	<b>12</b>
<b>IP 1. Quantities</b> .....	<b>12</b>
<b>IP 2. Proposed Schedule for the Procurement</b> .....	<b>12</b>
<b>IP 3. Obtaining Proposal Documents</b> .....	<b>12</b>
<b>IP 4. Questions, Clarifications and Omissions</b> .....	<b>12</b>
<b>IP 5. Addenda to RFP</b> .....	<b>12</b>
<b>IP 6. DBE Requirements for Transit Vehicle Manufacturers</b> .....	<b>13</b>
<b>IP 7. Buy America Certification</b> .....	<b>13</b>
<b>IP 8. Conditions, Exceptions, Reservations or Understandings</b> .....	<b>13</b>
<b>IP 9. Protest Procedures</b> .....	<b>14</b>
IP 9.1 Address .....	14
IP 9.2 Pre-Proposal Protests .....	14
IP 9.3 Protests on the Recommended Award .....	14
IP 9.4 FTA Review.....	14
<b>IP 10. Preparation of Proposals</b> .....	<b>14</b>
IP 10.1 Use of Proposal Forms.....	14
IP 10.2 Proposal Format Requirements.....	15
IP 10.3 Agency Treatment of Proprietary/Confidential Information .....	16
IP 10.4 Signing of Proposal Forms.....	16
IP 10.5 Modification or Withdrawal of Proposals.....	17
IP 10.6 Ownership and Cost of Proposal Development .....	17
<b>IP 11. Proposal Evaluation, Negotiation and Selection</b> .....	<b>17</b>
IP 11.1 Confidentiality of Proposals .....	17
IP 11.2 Duration of the Validity of Proposals .....	17
IP 11.3 Evaluation Committee .....	18
IP 11.4 Review of Proposals for Responsiveness and Proposers for Responsibility .....	18
IP 11.5 Proposal Selection Process .....	18
IP 11.6 Evaluation Procedures .....	19
IP 11.7 Evaluations of Competitive Proposals .....	19
<b>IP 12. Response to Proposals</b> .....	<b>21</b>
IP 12.1 Single Proposal Response.....	21
IP 12.2 Availability of Funds .....	21
IP 12.3 Agency Rights.....	21
IP 12.4 Execution of Contract .....	21
<b>IP 13. Conflicts of Interests and Gratuities</b> .....	<b>21</b>
<b>SECTION 3: GENERAL CONDITIONS</b> .....	<b>22</b>
<b>GC 1. Definitions</b> .....	<b>22</b>
<b>GC 2. Materials and Workmanship</b> .....	<b>23</b>
<b>GC 3. Conformance with Specifications and Drawings</b> .....	<b>23</b>
<b>GC 4. Inspection, Testing and Acceptance</b> .....	<b>23</b>
GC 4.1 General.....	23
GC 4.2 Risk of Loss .....	24
<b>GC 5. Title and Warranty of Title</b> .....	<b>24</b>

<b>GC 6. Intellectual Property Warranty</b> .....	<b>24</b>
<b>GC 7. Data Rights</b> .....	<b>25</b>
GC 7.1 Proprietary Rights/Rights in Data .....	25
GC 7.2 Access to Onboard Operational Data .....	25
<b>GC 8. Changes</b> .....	<b>25</b>
GC 8.1 Contractor Changes .....	25
GC 8.2 Agency Changes .....	25
<b>GC 9. Legal Clauses</b> .....	<b>26</b>
GC 9.1 Indemnification .....	26
GC 9.2 Suspension of Work .....	26
GC 9.3 Excusable Delays/Force Majeure .....	27
GC 9.4 Termination .....	28
GC 9.5 Compliance with Laws and Regulations .....	29
GC 9.6 Changes of Law .....	29
GC 9.7 Governing Law and Choice of Forum .....	29
GC 9.8 Disputes .....	30
GC 9.9 Maintenance of Records; Access by Agency; Right to Audit Records .....	31
GC 9.10 Confidential Information .....	32
GC 9.11 Conflicts of Interest, Gratuities .....	33
GC 9.12 General Nondiscrimination Clause .....	33
GC 9.13 Amendment and Waiver .....	33
GC 9.14 Remedies Not Exclusive .....	33
GC 9.15 Counterparts .....	33
GC 9.16 Severability .....	33
GC 9.17 Third-Party Beneficiaries .....	33
GC 9.18 Assignment of Contract .....	34
GC 9.19 Independent Parties .....	34
GC 9.20 Survival .....	34
<b>SP 1. Inspection, Tests and Repairs</b> .....	<b>35</b>
SP 1.1 Repair Performance .....	35
SP 1.2 Configuration and Performance Approval .....	35
SP 1.3 First Article Inspection – Production .....	36
SP 1.4 Post-Delivery Tests .....	36
SP 1.5 Repairs after Non-Acceptance .....	36
<b>SP 2. Deliveries</b> .....	<b>36</b>
SP 2.1 Bus Delivery .....	36
SP 2.2 Delivery Schedule .....	36
SP 2.3 Contract Deliverables .....	36
<b>SP 3. Options and Option Pricing</b> .....	<b>39</b>
<b>SP 4. Assignability of Options</b> .....	<b>40</b>
<b>SP 5. Payment</b> .....	<b>40</b>
SP 5.1 Payment Terms .....	40
SP 5.2 Payment of Taxes .....	40
<b>SP 6. Service and Parts</b> .....	<b>41</b>
SP 6.1 Contractor Service and Parts Support .....	41
SP 6.2 Documentation .....	41
SP 6.3 Parts Availability Guarantee .....	41
SP 6.4 Agency-Furnished Property .....	41
<b>SP 7. Federal Motor Vehicle Safety Standards (FMVSS)</b> .....	<b>42</b>
<b>SP 8. Insurance</b> .....	<b>42</b>
<b>SP 9. Software Escrow Account</b> .....	<b>42</b>
<b>SP 10. Sustainability</b> .....	<b>43</b>

<b>FR 1. Access to Records.....</b>	<b>44</b>
FR 1.1 Local Governments.....	44
FR 1.2 State Governments.....	44
<b>FR 2. Federal Funding, Incorporation of FTA Terms and Federal Changes .....</b>	<b>44</b>
<b>FR 3. Federal Energy Conservation Requirements .....</b>	<b>44</b>
<b>FR 4. Civil Rights Requirements.....</b>	<b>45</b>
<b>FR 5. No Government Obligation to Third Parties .....</b>	<b>45</b>
<b>FR 6. Program Fraud and False or Fraudulent Statements or Related Acts.....</b>	<b>46</b>
<b>FR 7. Suspension and Debarment .....</b>	<b>46</b>
<b>FR 8. Disadvantaged Business Enterprise (DBE) .....</b>	<b>46</b>
<b>FR 9. Clean Water Requirements .....</b>	<b>47</b>
<b>FR 10. Clean Air Requirements.....</b>	<b>47</b>
<b>FR 11. Compliance with Federal Lobbying Policy .....</b>	<b>47</b>
<b>FR 12. Buy America.....</b>	<b>47</b>
<b>FR 13. Testing of New Bus Models.....</b>	<b>48</b>
<b>FR 14. Pre-Award and Post-Delivery Audits .....</b>	<b>48</b>
<b>FR 15. Cargo Preference .....</b>	<b>48</b>
<b>FR 16. Fly America .....</b>	<b>49</b>
<b>FR 17. Contract Work Hours and Safety Standards Act.....</b>	<b>49</b>
<b>SECTION 6: TECHNICAL SPECIFICATIONS .....</b>	<b>51</b>
<b>TS 1. Scope.....</b>	<b>51</b>
<b>TS 2. Definitions .....</b>	<b>51</b>
<b>TS 3. Referenced Publications .....</b>	<b>55</b>
<b>TS 4. Legal Requirements .....</b>	<b>56</b>
<b>TS 5. Overall Requirements.....</b>	<b>56</b>
TS 5.1 Weight.....	56
TS 5.2 Capacity .....	56
TS 5.3 Service Life.....	56
TS 5.4 Maintenance and Inspection .....	56
TS 5.5 Interchangeability .....	57
TS 5.6 Training.....	57
<b>TS 5.7 Technical/Service Representatives .....</b>	<b>57</b>
TS 5.8 Operating Environment.....	57
TS 5.9 Noise .....	58
TS 5.10 Fire Safety.....	58
TS 5.11 Fire Suppression .....	58
TS 5.12 Respect for the Environment .....	58
<b>TS 6. Physical Size.....</b>	<b>59</b>
TS 6.1 Bus Length.....	59
TS 6.2 Bus Width .....	59
Body width shall be 102 in. (+0, -1 in.).....	59
TS 6.3 Bus Height .....	59
TS 6.4 Step Height .....	60
TS 6.5 Underbody Clearance .....	60
TS 6.6 Ramp Clearances .....	60
TS 6.7 Ground Clearance .....	60
TS 6.8 Floor Height.....	60
TS 6.9 Interior Headroom.....	60
TS 6.10 Aisle Width.....	61
<b>TS 7. Power Requirements.....</b>	<b>61</b>
TS 7.1 Top Speed .....	61

TS 7.2 Gradability .....	61
TS 7.3 Acceleration .....	61
TS 7.4 Operating Range .....	62
<b>TS 8. Fuel Economy (Design Operating Profile) .....</b>	<b>62</b>
<b>TS 9. Propulsion System .....</b>	<b>62</b>
<b>TS 10. Cooling Systems .....</b>	<b>65</b>
TS 10.1 Propulsion Cooling .....	65
TS 10.2 Charge Air Cooling .....	66
TS 10.3 Transmission Cooling .....	66
<b>TS 11. Transmission .....</b>	<b>66</b>
<b>TS 12. Regenerative Braking .....</b>	<b>67</b>
<b>TS 13. Engine Brake .....</b>	<b>67</b>
<b>TS 14. Mounting .....</b>	<b>67</b>
TS 14.1 Service .....	67
<b>TS 15. Hydraulic Systems .....</b>	<b>67</b>
TS 15.1 Fluid Lines .....	68
TS 15.2 Fittings and Clamps .....	68
TS 15.3 Charge Air Piping .....	68
<b>TS 16. Radiator .....</b>	<b>68</b>
<b>TS 17. Oil and Hydraulic Lines .....</b>	<b>68</b>
<b>TS 18. Fuel .....</b>	<b>69</b>
<b>TS 19. Emissions and Exhaust .....</b>	<b>69</b>
<b>TS 20. General .....</b>	<b>69</b>
TS 20.1 Design .....	69
<b>TS 21. Altoona Testing .....</b>	<b>69</b>
TS 21.1 Structural Validation .....	69
<b>TS 22. Distortion .....</b>	<b>69</b>
<b>TS 23. Resonance and Vibration .....</b>	<b>69</b>
TS 23.1 Motor Compartment Bulkheads .....	69
TS 23.2 Crashworthiness .....	70
<b>TS 24. Corrosion .....</b>	<b>70</b>
<b>TS 25. Towing .....</b>	<b>70</b>
<b>TS 26. Jacking .....</b>	<b>70</b>
<b>TS 27. Hoisting .....</b>	<b>71</b>
<b>TS 28. Floor .....</b>	<b>71</b>
TS 28.1 Design .....	71
TS 28.2 Strength .....	71
TS 28.3 Construction .....	71
<b>TS 29. Platforms .....</b>	<b>71</b>
TS 29.1 Driver’s Area .....	71
TS 29.2 Driver’s Platform .....	72
TS 29.3 Farebox .....	72
TS 29.4 Rear Step Area to Rear Area .....	72
<b>TS 30. Wheel Housing .....</b>	<b>73</b>
TS 30.1 Design and Construction .....	73
<b>TS 31. Suspension .....</b>	<b>73</b>
TS 31.1 General Requirements .....	73
TS 31.2 Alignment .....	73
TS 31.3 Springs and Shock Absorbers .....	73
<b>TS 32. Wheels and Tires .....</b>	<b>74</b>
TS 32.1 Wheels .....	74

TS 32.2 Tires .....	74
<b>TS 33. Steering .....</b>	<b>75</b>
TS 33.1 Steering and Tag Axles.....	75
TS 33.2 Steering Wheel.....	75
<b>TS 34. Drive Axle .....</b>	<b>76</b>
TS 34.1 Non-Drive Axle .....	76
<b>TS 35. Tag Axles.....</b>	<b>77</b>
<b>TS 36. Turning Radius .....</b>	<b>77</b>
<b>TS 37. Brakes.....</b>	<b>77</b>
TS 37.1 Service Brake.....	77
TS 37.2 Actuation.....	77
TS 37.3 Friction Material .....	78
TS 37.4 Hubs and Drums/Discs .....	78
TS 37.5 Parking/Emergency Brake .....	78
<b>TS 38. Interlocks .....</b>	<b>78</b>
TS 38.1 Passenger Door Interlocks .....	78
<b>TS 39. Pneumatic System .....</b>	<b>79</b>
TS 39.1 General.....	79
TS 39.2 Air Compressor.....	79
TS 39.3 Air Lines and Fittings .....	79
TS 39.4 Air Reservoirs .....	80
TS 39.5 Air System Dryer .....	80
<b>TS 40. Overview .....</b>	<b>80</b>
TS 40.1 Modular Design .....	81
<b>TS 41. Environmental and Mounting Requirements.....</b>	<b>81</b>
TS 41.1 Hardware Mounting.....	82
<b>TS 42. General Electrical Requirements.....</b>	<b>82</b>
TS 42.1 Batteries .....	82
TS 42.2 Grounds.....	84
TS 42.3 Low Voltage/Low Current Wiring and Terminals.....	84
TS 42.4 Electrical Components .....	85
TS 42.5 Electrical Compartments.....	85
<b>TS 43. General Electronic Requirements .....</b>	<b>85</b>
TS 43.1 Wiring and Terminals .....	85
<b>TS 44. Multiplexing.....</b>	<b>86</b>
TS 44.1 General.....	86
TS 44.2 System Configuration .....	86
<b>TS 45. Data Communications .....</b>	<b>87</b>
TS 45.1 General.....	87
TS 45.2 Drivetrain Level.....	87
TS 45.3 Multiplex Level.....	88
TS 45.4 Electronic Noise Control .....	89
<b>TS 46. Driver’s Area Controls .....</b>	<b>89</b>
TS 46.1 General.....	89
TS 46.2 Glare .....	89
TS 46.3 Visors/Sun Shades .....	89
TS 46.4 Driver’s Controls .....	89
TS 46.5 Normal Bus Operation Instrumentation and Controls .....	90
TS 46.6 Driver Foot Controls.....	93
TS 46.7 Driver Foot Switches .....	94
<b>TS 47. Driver’s Amenities .....</b>	<b>94</b>

TS 47.1 Coat Hanger .....	94
TS 47.2 Drink Holder .....	94
TS 47.3 Storage Box .....	94
<b>TS 48. Windshield Wipers and Washers .....</b>	<b>94</b>
TS 48.1 Windshield Wipers .....	94
TS 48.2 Windshield Washers .....	95
<b>TS 49. Driver’s Seat .....</b>	<b>95</b>
TS 49.1 Dimensions .....	95
TS 49.2 Seat Belt (3-Point w/ Orange Webbing) .....	96
TS 49.3 Adjustable Armrest .....	97
TS 49.4 Seat Control Locations.....	97
TS 49.5 Seat Structure and Materials .....	97
TS 49.6 Pedestal .....	97
TS 49.7 Seat Options.....	97
TS 49.8 Mirrors .....	97
<b>TS 50. General.....</b>	<b>98</b>
<b>TS 51. Windshield.....</b>	<b>98</b>
TS 51.1 Glazing.....	98
<b>TS 52. Driver’s Side Window.....</b>	<b>98</b>
<b>TS 53. Side Windows .....</b>	<b>99</b>
TS 53.1 Configuration.....	99
TS 53.2 Emergency Exit (Egress) Configuration.....	99
TS 53.3 Rear Window .....	99
<b>TS 54. Capacity and Performance.....</b>	<b>99</b>
<b>TS 55. Controls and Temperature Uniformity.....</b>	<b>100</b>
TS 55.1 Auxiliary Heater .....	100
<b>TS 56. Air Flow .....</b>	<b>100</b>
TS 56.1 Passenger Area.....	100
TS 56.2 Driver’s Area .....	101
TS 56.3 Controls for the Climate Control System (CCS) .....	101
TS 56.4 Driver’s Compartment Requirements .....	101
TS 56.5 Driver’s Cooling .....	101
<b>TS 57. Air Filtration .....</b>	<b>102</b>
<b>TS 58. Roof Ventilators .....</b>	<b>102</b>
<b>TS 59. Maintainability .....</b>	<b>102</b>
<b>TS 60. Entrance/Exit Area Heating.....</b>	<b>102</b>
<b>TS 61. Floor-Level Heating .....</b>	<b>102</b>
TS 61.1 Transit Coach.....	102
<b>TS 62. Design .....</b>	<b>102</b>
TS 62.1 Materials .....	103
<b>TS 63. Pedestrian Safety.....</b>	<b>103</b>
<b>TS 64. Repair and Replacement .....</b>	<b>103</b>
TS 64.1 Side Body Panels .....	103
<b>TS 65. Rain Gutters .....</b>	<b>103</b>
<b>TS 66. License Plate Provisions .....</b>	<b>103</b>
TS 66.1 Rub rails.....	103
<b>TS 67. Fender Skirts .....</b>	<b>104</b>
TS 67.1 Splash Aprons.....	104
<b>TS 68. Service Compartments and Access Doors.....</b>	<b>104</b>
TS 68.1 Access Doors .....	104
<b>TS 69. Bumpers .....</b>	<b>104</b>
TS 69.1 Location .....	104

TS 69.2 Front Bumper.....	104
TS 69.3 Rear Bumper.....	104
TS 69.4 Bumper Material.....	105
<b>TS 70. Finish and Color.....</b>	<b>105</b>
TS 70.1 Appearance.....	105
<b>TS 71. Decals, Numbering and Signing.....</b>	<b>105</b>
TS 71.1 Passenger Information.....	106
<b>TS 72. Exterior Lighting.....</b>	<b>106</b>
TS 72.1 Backup Light/Alarm.....	106
TS 72.2 Doorway Lighting.....	106
TS 72.3 Turn Signals.....	106
TS 72.4 Headlights.....	106
TS 72.5 Brake Lights.....	107
TS 72.6 Service Area Lighting (Interior and Exterior).....	107
<b>TS 73. General Requirements.....</b>	<b>107</b>
<b>TS 74. Interior Panels.....</b>	<b>107</b>
TS 74.1 Driver Area Barrier.....	107
TS 74.2 Modesty Panels.....	107
TS 74.3 Front End.....	108
TS 74.4 Rear Bulkhead.....	108
TS 74.5 Headlining.....	108
TS 74.6 Fastening.....	109
TS 74.7 Insulation.....	109
TS 74.8 Floor Covering.....	109
TS 74.9 Interior Lighting.....	109
TS 74.10 Passenger.....	110
TS 74.11 Driver’s Area.....	110
TS 74.12 Seating Areas.....	110
TS 74.13 Vestibules/Doors.....	110
TS 74.14 Step Lighting.....	110
TS 74.15 Ramp Lighting.....	110
TS 74.16 Turntable Lighting.....	110
TS 74.17 Farebox Lighting.....	111
<b>TS 75. Fare Collection.....</b>	<b>111</b>
<b>TS 76. Interior Access Panels and Doors.....</b>	<b>111</b>
TS 76.1 Floor Panels.....	111
<b>TS 77. Passenger Seating.....</b>	<b>111</b>
TS 77.1 Arrangements and Seat Style.....	111
TS 77.2 Rearward Facing Seats.....	112
TS 77.3 Padded Inserts/Cushioned Seats.....	112
TS 77.4 Seat back fitness.....	112
TS 77.5 Drain Hole in Seats.....	112
TS 77.6 Hip-to-Knee Room.....	112
TS 77.7 Foot Room.....	112
TS 77.8 Aisles.....	112
TS 77.9 Dimensions.....	113
TS 77.10 Structure and Design.....	113
TS 77.11 Construction and Materials.....	114
<b>TS 78. Passenger Assists.....</b>	<b>115</b>
TS 78.1 Assists.....	115
TS 78.2 Front Doorway.....	115
TS 78.3 Vestibule.....	116



TS 78.4 Rear Doorway(s).....	116
TS 78.5 Overhead.....	116
TS 78.6 Longitudinal Seat Assists.....	116
TS 78.7 Wheel Housing Barriers/Assists .....	116
<b>TS 79. Passenger Doors .....</b>	<b>117</b>
TS 79.1 Transit Coach.....	117
TS 79.2 Materials and Construction.....	117
TS 79.3 Door Glazing .....	117
TS 79.4 Door Projection.....	117
TS 79.5 Door Height Above Pavement.....	117
TS 79.6 Closing Force.....	117
TS 79.7 Actuators.....	118
TS 79.8 Emergency Operation .....	119
TS 79.9 Door Control.....	119
TS 79.10 Door Controller.....	119
TS 79.11 Door Open/Close .....	119
<b>TS 80. Accessibility Provisions.....</b>	<b>119</b>
TS 80.1 Loading Systems.....	119
TS 80.2 Lift .....	119
TS 80.3 Wheelchair Accommodations.....	120
TS 80.4 Interior Circulation .....	120
<b>TS 81. Destination Signs (LED) .....</b>	<b>120</b>
<b>TS 82. Passenger Information and Advertising .....</b>	<b>120</b>
TS 82.1 Interior Displays .....	120
TS 82.2 Exterior Displays .....	121
<b>TS 83. Passenger Stop Request/Exit Signal .....</b>	<b>121</b>
TS 83.1 Signal Chime .....	121
<b>TS 84. Communications.....</b>	<b>121</b>
TS 84.1 Camera Surveillance System .....	121
TS 84.2 Public Address System .....	121
TS 84.3 Automatic Passenger Counter (APC) .....	121
TS 84.4 Radio Handset and Control System.....	122
<b>TS 85. Event Data Recorders (EDR).....</b>	<b>122</b>
<b>TS 86. Vehicle Charging Requirements .....</b>	<b>122</b>
<b>TS 86.1 Plug-In Charging.....</b>	<b>122</b>
TS 86.2 On-Route Charging .....	122
<b>TS 87. Approved Equals .....</b>	<b>122</b>
<b>SECTION 7: WARRANTY REQUIREMENTS .....</b>	<b>124</b>
<b>WR 1. Basic Provisions.....</b>	<b>124</b>
WR 1.1 Warranty Requirements .....	124
WR 1.2 Voiding of Warranty .....	126
WR 1.3 Exceptions and Additions to Warranty .....	126
WR 1.4 Fleet Defects .....	127
<b>WR 2. Repair Procedures.....</b>	<b>128</b>
WR 2.1 Repair Performance.....	128
WR 2.2 Repairs by the Contractor .....	128
WR 2.3 Repairs by the Agency .....	128
WR 2.4 Warranty after Replacement/Repairs .....	129
WR 2.5 Forms .....	130

WR 2.6 Return of Parts .....	130
WR 2.7 Timeframe.....	130
WR 2.8 Reimbursements.....	130
<b>SECTION 8: QUALITY ASSURANCE.....</b>	<b>131</b>
<b>QA 1. Contractor’s In-Plant Quality Assurance Requirements .....</b>	<b>131</b>
QA 1.1 Quality Assurance Organization.....	131
QA 1.2 Quality Assurance Organization Functions .....	131
<b>QA 2. Inspection.....</b>	<b>133</b>
QA 2.1 Inspection Stations.....	133
QA 2.2 Resident Inspectors.....	133
<b>QA 3. Acceptance Tests .....</b>	<b>134</b>
QA 3.1 Responsibility .....	134
QA 3.2 Pre-Delivery Tests .....	134
Pre-Production Meeting.....	136
Prototype/Pilot Vehicle Production.....	137
Resident Inspection Process for Serial Production.....	139
Communications.....	142
Vehicle Release for Delivery.....	143
<b>SECTION 9: FORMS AND CERTIFICATIONS .....</b>	<b>144</b>
<b>CER 1. Proposer’s Checklist.....</b>	<b>144</b>
<b>CER 2. Request for Pre-Offer Change or Approved Equal.....</b>	<b>145</b>
<b>CER 3. Acknowledgement of Addenda.....</b>	<b>146</b>
<b>CER 4. Contractor Service and Parts Support Data .....</b>	<b>147</b>
<b>CER 5. Form for Proposal Deviation.....</b>	<b>148</b>
<b>CER 6. Pricing Schedule .....</b>	<b>149</b>
<b>CER 7. Pre-Award Evaluation Data Form.....</b>	<b>150</b>
<b>CER 8. Federal Certifications.....</b>	<b>151</b>
CER 8.1 Buy America Certification.....	151
CER 8.2 Debarment and Suspension Certification for Prospective Contractor .....	152
CER 8.3 Debarment and Suspension Certification (Lower-Tier Covered Transaction) .....	153
CER 8.4 Non-Collusion Affidavit.....	154
CER 8.5 Lobbying Certification.....	155
CER 8.6 Certificate of Compliance with Bus Testing Requirement .....	156
CER 8.7 DBE Approval Certification .....	157
CER 8.8 Federal Motor Vehicle Safety Standards .....	158
CER 9.1 Proposal Form.....	159
CER 9.2 Notice of Award .....	160
CER 9.3 Certification of Compliance with Standards, Certifications and Regulations .....	161
<b>CER 10. Vehicle Technical Information .....</b>	<b>165</b>
<b>SECTION 10: APPENDIXES.....</b>	<b>182</b>
<b>Appendix A: Guidelines for Calculating Liquidated Damages .....</b>	<b>182</b>
<b>Appendix B: Guidelines for Calculating Early Delivery Incentives.....</b>	<b>184</b>
<b>Appendix C: Examples of Evaluation Criteria .....</b>	<b>185</b>
<b>References.....</b>	<b>187</b>
<b>Abbreviation and Acronyms.....</b>	<b>188</b>

## SECTION 1: NOTICE OF REQUEST FOR PROPOSALS

### NR 1. Description of the Work to be Done

The Agency requests Proposals for the manufacture and delivery of six (6) forty-foot Electric Buses in accordance with the terms and conditions set forth in RFP CARTA2019-04

### NR 2. Obtaining Proposal Documents

Proposal documents may be obtained from CARTA electronically at [www.ridecarta.com](http://www.ridecarta.com) or [www.bcdcog.com](http://www.bcdcog.com)

### NR 3. Proposal Due Date and Submittal Requirements

Proposals must be received by January 03, 2020 by 3:00PM EST

1. Sealed Proposals shall be submitted to the following address:
  - a. For courier delivery or hand delivery:

Charleston Area Regional Transportation Authority (CARTA)  
Attn: Jason McGarry, Procurement/Contracts Administrator  
5790 Casper Padgett Way  
North Charleston, SC 29406

2. Envelopes or boxes containing Proposals shall be sealed and clearly labeled with the Agency's Proposal number and the solicitation title: **CARTA2019-04, 40-Foot Electric Bus**
3. Proposers are requested to submit to the Agency one (1) hard copy marked "Original," four (4) additional printed copies, and one (1) electronic copy of the Proposal. A Proposal is deemed to be late if it is received by the Agency after the deadline stated above. Proposals received after the submission deadline will be rejected.

### NR 4. Validity of Proposals

Proposals and subsequent offers shall be valid for a period of 180 days.

## **SECTION 2: INSTRUCTIONS TO PROPOSERS**

### **IP 1. Quantities**

The Work under these Contract documents consists of the manufacture and delivery of six (6) Electric Buses and associated goods and services such as charging stations, infrastructure, training materials and manuals.

### **IP 2. Proposed Schedule for the Procurement**

The following is the solicitation schedule for Proposers:

- Proposer communications and requests: December 20, 2019
- Proposal Due Date: January 02, 2020

### **IP 3. Obtaining Proposal Documents**

Proposal documents may be obtained electronically at [www.bcdcog.com](http://www.bcdcog.com) or [www.ridecarta.com](http://www.ridecarta.com)

### **IP 4. Questions, Clarifications and Omissions**

All correspondence, communication and contact in regard to any aspect of this solicitation or offers shall be only with the Procurement/Contracts Administrator, Jason McGarry, [jasonm@bcdcog.com](mailto:jasonm@bcdcog.com). Unless otherwise instructed by the Procurement/Contracts Administrator, Proposers and their representatives shall not make any contact with or communicate with any member of the Agency, or its employees and consultants, other than the designated Procurement/Contracts Administrator, in regard to any aspect of this solicitation or offers.

At any time during this procurement up to the time specified in “Proposed Schedule for the Procurement,” Proposers may request, in writing, a clarification or interpretation of any aspect, a change to any requirement of the RFP, or any addenda to the RFP. Requests may include suggested substitutes for specified items and for any brand names, which whenever used in this solicitation shall mean the brand name or approved equal. Such written requests shall be made to the Procurement/Contracts Administrator. The Proposer making the request shall be responsible for its proper delivery to the Agency as identified on the form Request for Pre- Offer Change or Approved Equal. Any request for a change to any requirement of the Contract documents must be fully supported with technical data, test results or other pertinent information showing evidence that the exception will result in a condition equal to or better than that required by the RFP, without a substantial increase in cost or time requirements.

All responses to Request for Pre- Offer Change or Approved Equal shall be provided to all Proposers. Any response that is not confirmed by a written addendum shall not be official or binding on the Agency.

If it should appear to a prospective Proposer that the performance of the Work under the Contract, or any of the matters relating thereto, is not sufficiently described or explained in the RFP or Contract documents, or that any conflict or discrepancy exists between different parts of the Contract or with any federal, state, local or Agency law, ordinance, rule, regulation or other standard or requirement, then the Proposer shall submit a written request for clarification to the Agency within the time period specified above.

### **IP 5. Addenda to RFP**

The Agency reserves the right to amend the RFP at any time in accordance with “Proposed Schedule for the Procurement.” Any amendments to the RFP shall be described in written addenda. Notification of or the addenda also will be distributed to all such prospective Proposers officially known to have received the RFP. Failure of any prospective Proposer to receive the notification or addenda shall not relieve the Proposer from any obligation under the RFP therein. All addenda issued shall become part of the RFP. Prospective Proposers shall acknowledge the receipt of each individual addendum in their Proposals on the form Acknowledgement

of Addenda. Failure to acknowledge in the Proposal receipt of addenda may at the Agency's sole option disqualify the Proposal.

If the Agency determines that the addenda may require significant changes in the preparation of Proposals, the deadline for submitting the Proposals may be postponed no fewer than ten (10) days from the date of issuance of addenda or by the number of days that the Agency determines will allow Proposers sufficient time to revise their Proposals. Any new Due Date shall be included in the addenda.

## **IP 6. DBE Requirements for Transit Vehicle Manufacturers**

Pursuant to Title 49, Code of Federal Regulations, Part 26.49, a Proposer, as a condition of being authorized to respond to this solicitation, must certify by completing the form DBE Approval Certification that it has on file with the Federal Transportation Administration (FTA) an approved or not disapproved annual disadvantaged business enterprise (DBE) subcontracting participation goal.

## **IP 7. Buy America Certification**

This Contract is subject to the "Buy America" requirements of 49 United States Code (USC) §5323(j) and 49 Code of Federal Regulations (CFR) Part 661, as may be amended from time to time, and applicable federal regulations. Prospective Proposers' attention is directed to 49 CFR §661.11, "Rolling Stock Procurements." Prospective Proposers have the responsibility to comply with the cited and any governing statutes and regulations, including official interpretations.

A Proposer shall submit to the Agency the appropriate Buy America certification, included in this document, with all offers on FTA-funded contracts. Proposals that are not accompanied by a properly completed Buy America certification are subject to the provisions of 49 CFR 661.13 and will be rejected as nonresponsive.

The two signature blocks on the Buy America certificate are mutually exclusive. Proposers shall sign only one signature block on the certificate. Signing both signature blocks will make the Proposal nonresponsive. A false certification is a criminal act in violation of 18 USC §1001.

Any party may petition the FTA to investigate a successful Proposer's compliance with the Buy America certification. The procedures are set out in 49 CFR Part 661.15. If the FTA determines that the evidence indicates noncompliance, the FTA will require the Agency to initiate an investigation. The successful Proposer has the burden of proof to establish compliance with its certification. If the successful Proposer fails to so demonstrate compliance, then the successful Proposer will be required to substitute sufficient domestic materials without revision of the original Contract terms. Failure to do so will be a breach of the Contract and may lead to the initiation of debarment proceedings under 49 CFR Part 29.

## **IP 8. Conditions, Exceptions, Reservations or Understandings**

Proposers are cautioned to limit exceptions, conditions and limitations to the provisions of this RFP, as they may be determined to be so fundamental as to cause rejection of the Proposal for not responding to the requirements of the RFP.

Any and all Deviations must be explicitly, fully and separately stated in the Proposal by completing the Form for Proposal Deviation, setting forth at a minimum the specific reasons for each Deviation so that it can be fully considered and, if appropriate, evaluated by the Agency. All Deviations shall be evaluated in accordance with the appropriate evaluation criteria and procedures and may result in the Proposer receiving a less favorable evaluation than without the Deviation.

The Form for Proposal Deviations shall be included in the Technical package.

## **IP 9. Protest Procedures**

All protests must be in writing, stating the name and address of protestor, a contact person, Contract number and title. Protests shall specify in detail the grounds of the protest and the facts supporting the protest.

### **IP 9.1 Address**

All protests must be addressed as follows:

- Agency: BCD Council of Governments
- Address: 5790 Casper Padgett Way North Charleston, SC 29406

Protests not properly addressed to the address shown above may not be considered by the Agency.

### **IP 9.2 Pre-Proposal Protests**

Pre-Proposal protests are protests based upon the content of the solicitation documents. Three copies of Pre-Proposal protests must be received by the Agency's office no later than fifteen (15) calendar days prior to the Due Date. Protests will be considered and either denied or sustained in part or in whole, in writing, in a manner that provides verification of receipt, prior to the Due Date for Proposals. A written decision specifying the grounds for sustaining all or part of or denying the protest will be transmitted to the protestor prior to the Due Date for Proposals in a manner that provides verification of receipt prior to the Due Date for Proposals. If the protest is sustained, then the Proposal Due Date may be postponed and an addendum issued to the solicitation documents or, at the sole discretion of the Agency, the solicitation may be canceled. If the protest is denied, then Proposals will be received and opened on the scheduled date unless a protest is filed with FTA. See "FTA Review," below.

### **IP 9.3 Protests on the Recommended Award**

All Proposers will be notified of the recommended award. This notice will be transmitted to each Proposer at the address contained in its Proposal form in a manner that provides verification of receipt. Any Proposer whose Proposal has not lapsed may protest the recommended award on any ground not specified in "Pre-Proposal Protests," above. Three (3) copies of a full and complete written statement specifying in detail the grounds of the protest and the facts supporting the protest must be received by the Agency at the appropriate address in "Address," above, no later than fifteen (15) calendar days after the date such notification is received. Prior to the issuing of the Notice of Award, a written decision stating the grounds for allowing or denying the protest will be transmitted to the protestor and the Proposer recommended for award in a manner that provides verification of receipt.

### **IP 9.4 FTA Review**

After such administrative remedies have been exhausted, an interested party may file a protest with the Federal Transit Administration of the U.S. Department of Transportation pursuant to the procedures provided in the FTA C 4220.1For its successor. FTA review is limited to the alleged failure of the Agency to have written protest procedures, the alleged failure of the Agency to follow those procedures, the alleged failure of the Agency to review a protest or the alleged violation of federal law or regulation.

## **IP 10. Preparation of Proposals**

### **IP 10.1 Use of Proposal Forms**

Proposers are advised that the forms contained in this RFP are required to be used for submission of a Proposal.

## IP 10.2 Proposal Format Requirements

Proposals shall be submitted in four separately sealed packages identified below. Each package shall be marked as specified below and shall contain all the Proposal documents for which the package is required to be marked and shall include no other documents. These same requirements shall apply to any best and final offers (BAFOs) that may be requested.

Proposers shall submit one original (marked clearly as such), four (4) hard copies, and one (1) digital, each containing an electronic PDF copy of the Proposal to the Agency. In case of any discrepancies, the original will be considered by the Agency in evaluating the Proposal, and the electronic version is provided for the Agency's administrative convenience only.

The hard-copy Proposals shall be prepared double-sided on 8½ × 11 in. paper in at least 11-point font. Use of 11 × 17 in. foldout sheets for large tables, charts or diagrams is permissible but should be limited. Elaborate formatting is not necessary. Do not provide promotional or advertising information, unless this information is requested and/or is necessary to support the technical submittal.

### Package 1: Technical Proposal Requirements

1. Letter of Transmittal
2. Technical Proposal
3. Acknowledgement of Addenda
4. Contractor Service and Parts Support Data
5. Form for Proposal Deviation (without price data)
6. Vehicle Questionnaire
7. References and Non-Priced Information
8. Engineering organization chart, engineering change control procedure, field modification process
9. Manufacturing facilities plant layout, other contracts, staffing
10. Production and delivery schedule and other Contract commitments for the duration of this Contract
11. Management Plan

### Package 2: Price Proposal Requirements

Each Price Proposal shall be on the prescribed Proposal form(s) and shall be for the entire Contract, including all Proposal items.

1. Letter of Transmittal
2. Pricing Schedule, (including but not limited to such pricing elements as charging stations, option buses, spare parts package, manuals, training, special tools and test equipment)

The Proposer is required to complete and execute the Agency's Pricing Schedule, contained as part of the Proposal documents, and provide same in the Price Proposal. Charleston Area Regional Transportation Authority (CARTA) is tax –exempt and shall be reflected in the price proposal.

### Package 3: Qualification Package Requirements

1. Pre-Award Evaluation Data Form
2. A copy of the three (3) most recent financial statements audited by an independent third party or a statement from the Proposer regarding how financial information may be reviewed by the Agency
3. Letter for insurance, indicating the Contractor's ability to obtain the insurance coverage in accordance with the RFP requirements
4. All federal certifications: Buy America Certification, Debarment and Suspension Certification for Prospective Contractor, Debarment and Suspension Certification (Lower-Tier Covered Transaction),

Non-Collusion Affidavit, Lobbying Certification, Certificate of Compliance with Bus Testing Requirement, DBE Approval Certification, and Federal Motor Vehicle Safety Standards

#### **Package 4: Proprietary/Confidential Information Package Requirements**

The Proposer is directed to collect and submit any information it deems to be proprietary or confidential in nature in a separate marked and sealed package. If there is no confidential information, then the Proposer should include a statement to that effect. Subject package shall be submitted in accordance with the terms and conditions governing the submittal of Proposer's Proposal to this RFP. Blanket-type identification by designating whole pages or sections as containing proprietary information, trade secrets or confidential commercial and financial information will not ensure confidentiality. The specific proprietary information, trade secrets or confidential commercial and financial information must be clearly identified as such.

The Proposer is advised that the Agency is public and as such may be subject to certain state and/or local Public Records Act provisions regarding the release of information concerning this RFP. If a request is received by the Agency for the release of Proposer's proprietary/confidential information, then subject request will be referred to the Proposer for review and consideration. If Proposer chooses to declare the information proprietary/confidential and withhold it from release, then it shall defend and hold harmless the Agency from any legal action arising from such a declaration.

#### **IP 10.3 Agency Treatment of Proprietary/Confidential Information**

Access to government records is governed by the State of South Carolina. Except as otherwise required to be disclosed by applicable law, the Agency will exempt from disclosure proprietary information identified in Package 4.

Upon a request for records from a third party regarding this Proposal, the Agency will notify the Proposer in writing. The Proposer must respond within thirty business days with the identification of any and all "proprietary, trade secret or confidential commercial or financial" information. Failure to respond within the allowed period shall be deemed an approval to release. The Proposer shall indemnify the Agency's defense costs associated with its refusal to produce such identified information; otherwise, the requested information may be released.

The Agency shall employ sound business practices no less diligent than those used for the Agency's own confidential information to protect the confidence of all licensed technology, software, documentation, drawings, schematics, manuals, data and other information and material provided by Proposers and the Contractor pursuant to the Contract that contain confidential commercial or financial information, trade secrets or proprietary information as defined in or pursuant to the law against disclosure of such information and material to third parties, except as permitted by the Contract. The Contractor shall be responsible for ensuring that confidential commercial or financial information, trade secrets or proprietary information—with such determinations to be made by the Agency at its sole discretion—bears appropriate notices relating to its confidential character.

#### **IP 10.4 Signing of Proposal Forms**

Proposals shall include firm name (and, in the event that the Proposer is a joint venture, the names of the individual firms comprising the joint venture); business address; and the name, title, business address, telephone number, facsimile (fax) number and email address of the responsible individual(s) who may be contacted during the Proposal evaluation period for scheduling oral presentations and for receiving notices from the Agency. The Proposer shall submit with its Proposal a copy of the joint venture agreement.

Proposals shall be signed by those individual(s) authorized to bind the Proposer. The Proposer shall submit evidence of the official's authority to act for and bind the Proposer in all matters relating to the Proposal.(In



the event that the Proposer is a joint venture or consortium, a representative of each of the members of the joint venture or consortium shall execute the Proposal. Each joint venture or consortium member is jointly and severally liable for the joint venture or consortium.)

### **IP 10.5 Modification or Withdrawal of Proposals**

A modification of a Proposal already received will be accepted by the Agency only if the modification is received prior to the Proposal Due Date, is specifically requested by the Agency, or is made with a requested BAFO. All modifications shall be made in writing and executed and submitted in the same form and manner as the original Proposal.

A Proposer may withdraw a Proposal already received prior to the Proposal Due Date by submitting to the Agency, in the same manner as the original Proposal, a written request for withdrawal executed by the Proposer's authorized representative. After the Proposal Due Date, a Proposal may be withdrawn only if the Agency fails to award the Contract within the Proposal validity period prescribed in "Duration of the Validity of Proposals," or any agreed-upon extension thereof. The withdrawal of a Proposal does not prejudice the right of a Proposer to submit another Proposal within the time set for receipt of Proposals.

### **IP 10.6 Ownership and Cost of Proposal Development**

All proposals will become the property of the Agency.

This RFP does not commit the Agency to enter into a Contract, to pay any costs incurred in the preparation or presentation of a Proposal, nor to procure or contract for the equipment.

## **IP 11. Proposal Evaluation, Negotiation and Selection**

Proposals will be evaluated, negotiated, selected and any award made in accordance with the criteria and procedures described below. The approach and procedures are those applicable to a competitive negotiated procurement whereby Proposals are evaluated to determine which Proposals are within a Competitive Range. Discussions and negotiations may then be carried out with Proposers within the Competitive Range, after which BAFOs may be requested.

However, the Agency may select a Proposal for award without any discussions or negotiations or request for any BAFOs. Subject to the Agency's right to reject any or all Proposals, the Proposer whose Proposal is found to be most advantageous to the Agency will be selected, based upon consideration of the criteria of "Proposal Selection Process," below.

### **IP 11.1 Confidentiality of Proposals**

Proposals will not be publicly opened. All Proposals and evaluations will be kept strictly confidential throughout the evaluation, negotiation and selection process, except as otherwise required by applicable law. Only the members of the Selection Committee and Evaluation Team and other Agency officials, employees and agents having a legitimate interest will be provided access to the Proposals and evaluation results during this period.

### **IP 11.2 Duration of the Validity of Proposals**

Proposals and subsequent offers shall be valid for the period stated in "Section 1: Notice of Request for Proposals." The Agency may request Proposers to extend the period of time specified herein by written agreement between the Agency and the Proposer(s) concerned.

### **IP 11.3 Evaluation Committee**

An Evaluation Committee, which will include officers, employees and agents of the Agency, will be established. The Evaluation Committee will carry out the detailed evaluations, including establishing the Competitive Range, carrying out negotiations and making the selection of the Proposer, if any, that may be awarded the Contract.

The Evaluation Committee may report its recommendations and findings to the appropriate Agency individual or body responsible for awarding the Contract.

### **IP 11.4 Review of Proposals for Responsiveness and Proposers for Responsibility**

Each Proposal will be reviewed to determine if the Proposal is responsive to the submission requirements outlined in this RFP and if the Proposer is responsible.

A responsive Proposal is one that follows the requirements of this RFP, includes all documentation, is submitted in the format outlined in this RFP, is of timely submission, and has the appropriate signatures as required on each document. Failure to comply with these requirements may result in the Proposal being deemed nonresponsive.

A responsible Proposer is one that demonstrates the capability to satisfy the commercial and technical requirements set forth in the Solicitation. A Proposer's failure to demonstrate that it is responsible may result in the proposal being rejected.

Any Proposal found to be nonresponsive or Proposer found to be non-responsible will not be considered further for award. Proposals that do not comply with the RFP instructions and requirements or do not include the required information may be rejected as insufficient and may not be further considered. The Agency reserves the right to request a Proposer to provide additional information and/or to clarify information. The Agency's determination regarding the responsiveness of a Proposal and the responsibility of a Proposer shall be final.

### **IP 11.5 Proposal Selection Process**

The following describes the process by which Proposals will be evaluated and a selection made for a potential award. Any such selection of a Proposal shall be made by consideration of only the criteria set forth below.

"Qualification Requirements" specifies the requirements for determining responsible Proposers, all of which must be met by a Proposer to be found qualified. Final determination of a Proposer's qualification will be made based upon all information received during the evaluation process and as a condition for award.

"Proposal Evaluation Criteria" contains all the evaluation criteria, and their relative order of importance, by which a Proposal from a qualified Proposer will be considered for selection. An award, if made, will be to a responsible Proposer for a Proposal that is found to be in the Agency's best interests, based on price and other evaluation criteria considered. The procedures to be followed for these evaluations are provided in "Evaluation Procedures," below.

#### **Qualification Requirements**

The following are the requirements for qualifying responsible Proposers. All of these requirements should be met; therefore, they are not listed in any particular order of importance. Any Proposal that the Evaluation Committee finds does not meet these requirements, and cannot be made to meet these requirements, may be

determined by the Evaluation Committee not to be responsible and the Proposal rejected. The requirements are as follows:

1. Sufficient financial strength, resources and capability to finance the Work to be performed and to complete the Contract in a satisfactory manner, as measured by the following:
2. Evidence that the human and physical resources are sufficient to perform the Contract as specified and to ensure delivery of all equipment within the time specified in the Contract, to include the following:
3. Evidence that Proposer is qualified in accordance with the provisions of “Section 8: Quality Assurance.”
4. Evidence of satisfactory performance and integrity on contracts in making deliveries on time, meeting specifications and warranty provisions, parts availability and steps Proposer took to resolve any judgments, liens, Fleet Defects history or warranty claims. Evidence shall be by client references.

### **Proposal Evaluation Criteria**

The following are the complete criteria, listed in their relative order of importance, by which Proposals from responsible Proposers will be evaluated and ranked for the purposes of determining any Competitive Range and to make any selection of a Proposal for a potential award. Any exceptions, conditions, reservations or understandings explicitly, fully and separately stated on the Form for Proposal Deviation, which do not cause the Agency to consider a Proposal to be outside the Competitive Range, will be evaluated according to the respective evaluation criteria and sub-criteria that they affect.

The criteria are listed numerically by their relative order of importance. However, certain criteria may have sub-criteria identified that are listed by their relative order of importance within the criterion they comprise. Also, certain sub-criteria may have sub-criteria that are listed by their relative degree of importance within the specific sub-criterion they comprise..

### **IP 11.6 Evaluation Procedures**

Proposals will be analyzed for conformance with the instructions and requirements of the RFP and Contract documents. Proposals that do not comply with these instructions and do not include the required information may be rejected as insufficient or not be considered for the Competitive Range. The Agency reserves the right to request that a Proposer provide any missing information and make corrections. Proposers are advised that the detailed evaluation forms and procedures will follow the same Proposal format and organization specified in “Preparation of Proposals.” Therefore, Proposers should pay close attention to and strictly follow all instructions. Submittal of a Proposal will signify that the Proposer has accepted the whole of the Contract documents, except such conditions, exceptions, reservations or understandings explicitly, fully and separately stated on the forms and according to the instructions of the Form for Proposal Deviation. Any such conditions, exceptions, reservations or understandings that do not result in the rejection of the Proposal are subject to evaluation under the criteria set forth in “Proposal Selection Process.”

Evaluations will be made in strict accordance with all the evaluation criteria specified in “Proposal Selection Process,” above. The Agency will choose the Proposal that it finds to be most advantageous to the Agency, based upon the evaluation criteria.

### **IP 11.7 Evaluations of Competitive Proposals**

1. **Qualification of responsible Proposers.** Proposals will be evaluated to determine the responsibility of Proposers. A final determination of a Proposer’s responsibility will be made

upon the basis of initial information submitted in the Proposal, any information submitted upon request by the Agency, information submitted in a BAFO, and information resulting from Agency inquiry of Proposer's references and its own knowledge of the Proposer.

2. **Detailed evaluation of Proposals and determination of Competitive Range.** The Agency will carry out and document its evaluations in accordance with the criteria and procedures set forth in "Proposal Selection Process." Any Proposal deficiencies that may render a Proposal unacceptable will be documented. The Agency will make specific note of questions, issues, concerns and areas requiring clarification by Proposers and to be discussed in any meetings with Proposers that the Agency finds to be within the Competitive Range.

Rankings of the Proposals against the evaluation will then be made for determining which Proposals are within the Competitive Range, or may reasonably be made to be within the Competitive Range.

3. **Proposals not within the Competitive Range.** Proposers of any Proposals that have been determined by the Agency as not in the Competitive Range, and that cannot be reasonably made to be within the Competitive Range, will be notified in accordance with the Agency's policies.
4. **Discussions with Proposers in the Competitive Range.** The Proposers whose Proposals are found by the Agency to be within the Competitive Range, or that may be reasonably made to be within the Competitive Range, will be notified and any questions or requests for clarifications provided to them in writing. Each such Proposer may be invited for an interview and discussions with the Agency to discuss answers to written or oral questions, clarifications and any facet of its Proposal.

In the event that a Proposal that has been included in the Competitive Range contains conditions, exceptions, reservations or understandings to any Contract requirements as provided in the Form for Proposal Deviation, said conditions, exceptions, reservations or understandings may be negotiated during these meetings. However, the Agency shall have the right to reject any and all such conditions and exceptions, and instruct the Proposer to amend its Proposal and remove said conditions and exceptions; and any Proposer failing to do so may cause the Agency to find such Proposal to be outside the Competitive Range.

No information, financial or otherwise, will be provided to any Proposer about any of the Proposals from other Proposers, to the extent permitted by applicable law. Proposers will not be given a specific price or specific financial requirements they must meet to gain further consideration, except that proposed prices may be considered to be too high with respect to the marketplace or unacceptable. Proposers will not be told of their rankings among the other Proposers prior to Contract award.

5. **Factory and site visits.** The Agency reserves the right to conduct factory visits of the Proposer's facilities and/or the facilities of major sub-suppliers included in the Proposal.
6. **Best and final offers.** After all interviews have been completed, the Proposers in the Competitive Range may be afforded the opportunity to amend their Proposals and make their BAFOs. The Request for BAFOs shall include the following:
7. **Debriefing.** Subsequent to the award, the unsuccessful Proposers will be notified and may request a debriefing. Proposers will be debriefed in accordance with Agency policies, including information regarding the shortcomings of their Proposal.

## **IP 12. Response to Proposals**

### **IP 12.1 Single Proposal Response**

If only one Proposal is received in response to this RFP and it is found by the Agency to be acceptable, then a price or cost analysis, or both, possibly including an audit, may be performed by or for the Agency. The Proposer has agreed to such analysis by submitting a Proposal in response to this RFP.

### **IP 12.2 Availability of Funds**

This procurement is subject to the availability of funding.

### **IP 12.3 Agency Rights**

The Agency reserves the right to cancel the procurement in whole or in part, at its sole discretion, at any time before the Contract is fully executed and approved on behalf of the Agency.

The Agency reserves the right to reject any or all Proposals, to undertake discussions with one or more Proposers, and to accept that Proposal or modified Proposal which, in its judgment, will be most advantageous to the Agency, considering price and other evaluation criteria. The Agency reserves the right to determine any specific Proposal that is conditional or not prepared in accordance with the instructions and requirements of this RFP to be nonresponsive. The Agency reserves the right to waive any Defects, or minor informalities or irregularities in any Proposal that do not materially affect the Proposal or prejudice other Proposers.

If there is any evidence indicating that two or more Proposers are in collusion to restrict competition or are otherwise engaged in anti-competitive practices, the Proposals of all such Proposers shall be rejected, and such evidence may be a cause for disqualification of the participants in any future solicitations undertaken by the Agency.

The Agency may reject a Proposal that includes unacceptable Deviations as provided in the Form for Proposal Deviation.

### **IP 12.4 Execution of Contract**

The acceptance of a Proposal for award, if made, shall be evidenced in writing by a notice of award of Contract delivered to the Proposer whose Proposal is accepted. Upon notice of award of the Contract to a Proposer, the Proposer shall commence performance under the Contract by furnishing any required bonds, and by furnishing copies of the certificates of insurance required to be procured by the Contractor pursuant to the Contract documents within ten (10) calendar days after the date of receipt of the notice of award. Failure to fulfill these requirements within the specified time is cause for termination of the Contract under "Termination for Default" in Section 3.

## **IP 13. Conflicts of Interests and Gratuities**

Proposers are prohibited from engaging in any practice that may be considered a conflict of interest under existing Agency policies and/or state law, and to refrain from participating in any gifts, favors or other forms of compensation that may be viewed as a gratuity in accordance with existing policies and laws.

## SECTION 3: GENERAL CONDITIONS

### GC 1. Definitions

The following are definitions of special terms used in this document:

**Agency:** Charleston Area Regional Transportation Authority

**Authorized Signer:** The person who is executing this Contract on behalf of the Contractor and who is authorized to bind the Contractor.

**Best and Final Offer (BAFO):** The last Proposal made by a Proposer. If a BAFO is not specifically requested by the Agency, or if the Proposer does not promptly respond to a request for a BAFO, then the most recent, current Proposal is the BAFO.

**Class 1 Failure (physical safety):** A failure that could lead directly to passenger or operator injury and represents a severe crash situation.

**Class 2 Failure (road call):** A failure resulting in an en route interruption of revenue service. Service is discontinued until the bus is replaced or repaired at the point of failure.

**Competitive Range:** The range of proposals that are identified as the most highly rated, unless the range is further reduced for purposes of efficiency.

**Contract:** The Proposal and its acceptance by the Agency as manifested by the Contract documents specified in “Section 10: Contract.”

**Executive Director:** The person who is executing this Contract on behalf of the Agency and who has complete and final authority except as limited herein.

**Contractor:** The successful Proposer who is awarded a Contract for providing all buses and equipment described in the Contract documents.

**Days:** Unless otherwise stated, “days” shall mean calendar days.

**Defect:** Patent or latent malfunction or failure in manufacture, installation or design of any component or subsystem.

**Deviation:** Variance from a requirement or specification that does not alter the basis of a contractor adversely affects its performance.

**Due Date:** The date and time by which Proposals must be received by the Agency as specified in “Section 1: Notice of Request for Proposals.”

**Extended Warranty:** A warranty available for purchase above the standard warranty.

**Fatigue Failure (Corrosion Fatigue):** The mechanical degradation of a material under the joint action of corrosion and cyclic loading.

**Pass-Through Warranty:** A warranty provided by the Contractor but administered directly with the component Supplier.

**Proposal:** A promise, if accepted, to deliver equipment and services according to the underlying solicitation of the Agency documented using the prescribed form in the solicitation, including any Proposal or BAFO.

**Proposer:** A legal entity that makes a Proposal.

**Related Defect:** Damage inflicted on any component or subsystem as a direct result of a separate Defect.

**Solicitation:** An Agency's request for proposals.

**Superior Warranty:** A warranty still in effect after all contractually required warranties have expired. The remaining warranty is administered directly between the sub-Supplier and the Agency.

**Supplier:** Any manufacturer, company or Agency providing units, components or subassemblies for inclusion in the bus that are installed by the Contractor. Supplier items shall require qualification by type and acceptance tests in accordance with requirements defined in "Section 8: Quality Assurance."

**Subcontractor:** Any manufacturer, company or Agency providing units, components or subassemblies for inclusion in the bus that are installed by a Subcontractor. Subcontractor items shall require qualification by type and acceptance tests in accordance with requirements defined in "Section 8: Quality Assurance."

**Work:** Any and all labor, supervision, services, materials, machinery, equipment, tools, supplies and facilities called for by the Contract and necessary to the completion thereof.

## **GC 2. Materials and Workmanship**

The Contractor shall be responsible for all materials and workmanship in the construction of the bus and all accessories used, whether the same are manufactured by the Contractor or purchased from a Supplier. This provision excludes any equipment leased or supplied by the Agency, except insofar as such equipment is damaged by the failure of a part or component for which the Contractor is responsible, or except insofar as the damage to such equipment is caused by the Contractor during the manufacture of the buses.

## **GC 3. Conformance with Specifications and Drawings**

Materials furnished and Work performed by the Contractor shall conform to the requirements of the Technical Specifications and other Contract documents. Notwithstanding the provision of drawings, technical specifications or other data by the Agency, the Contractor shall have the responsibility of supplying all parts and details required to make the bus complete and ready for service even though such details may not be specifically mentioned in the drawings and specifications. Items that are installed by the Agency shall not be the responsibility of the Contractor unless they are included in this Contract.

Omissions from the Contract specifications, or the inaccurate description of details of Work that are manifestly necessary to carry out the intent of the Contract specifications, or that are customarily performed, shall not relieve the Contractor from performing such omitted Work or inaccurately described details of the Work, and they shall be performed as if fully and correctly set forth and described.

## **GC 4. Inspection, Testing and Acceptance**

### **GC 4.1 General**

The Agency's Representative shall at all times have access to the Work, the Contractor and, through the Contractor, its Suppliers. The Contractor and its Suppliers shall furnish every reasonable facility for

ascertaining that the materials and the workmanship are in accordance with the requirements of the Contract Documents. All Work done shall be subject to the Agency Representative's inspection and approval in accordance with the approved Work products developed as a result of the Contract Documents.

The pre-delivery tests and inspections shall be performed at the Contractor's plant; they shall be performed in accordance with the procedures defined in "Section 8: Quality Assurance"; and they may be witnessed by the resident inspector. When a bus passes these tests and inspections, the resident inspector shall authorize release of the bus.

Within fifteen (15) calendar days after arrival at the designated point of delivery, the bus shall undergo the Agency tests defined in "Post-Delivery Tests." If the bus passes these tests or if the Agency does not notify the Contractor of non-acceptance within 15 calendar days after delivery, then acceptance of the bus by the Agency occurs on the 15th day after delivery. If the bus fails these tests, it shall not be accepted until the repair procedures defined in "Repairs after Non-Acceptance" have been carried out and the bus retested until it passes. Acceptance occurs earlier if the Agency notifies the Contractor of early acceptance or places the bus in revenue service.

#### **GC 4.2 Risk of Loss**

The Agency shall assume risk of loss of the bus on delivery, as defined in "Bus Delivery." Prior to this delivery, the Contractor shall have risk of loss of the bus, including any damages sustained during the delivery regardless of the status of title or any payments related to the bus. Drivers shall keep a maintenance log en route, and it shall be delivered to the Agency with the bus. If the bus is released back to the Contractor for any reason, then the Contractor has the risk of loss upon such release.

#### **GC 5. Title and Warranty of Title**

Adequate documents for registering the bus in Charleston, SC shall be provided to the Agency not less than 10 business days before delivery to the Agency. Upon acceptance of each bus, the Contractor warrants that the title shall pass to the Agency free and clear of all encumbrances.

#### **GC 6. Intellectual Property Warranty**

The Agency shall advise the Contractor of any impending patent suit related to this Contract against the Agency and provide all information available. The Contractor shall defend any suit or proceeding brought against the Agency based on a claim that any equipment, or any part thereof, furnished under this Contract constitutes an infringement of any patent, and the Contractor shall pay all damages and costs awarded therein, excluding incidental and consequential damages against the Agency. In case said equipment, or any part thereof, is in such suit held to constitute infringement and use of said equipment or parts is enjoined, the Contractor shall, at its own expense and at its option, either procure for the Agency the right to continue using said equipment or part, or replace same with non-infringing equipment, or modify it so it becomes non-infringing.

The Contractor's obligations under this section are discharged and the Agency shall hold the Contractor harmless with respect to the equipment or part if it was specified by the Agency and all requests for substitutes were rejected, and the Contractor advised the Agency under "Questions, Clarifications and Omissions" of a potential infringement, in which case the Contractor shall be held harmless.



## **GC 7. Data Rights**

### **GC 7.1 Proprietary Rights/Rights in Data**

The term “subject data” used in this clause means recorded information, whether or not copyrighted, that is delivered or specified to be delivered under the Contract. It includes the proprietary rights of the following:

- Shop drawings and working drawings
- Technical data including manuals or instruction materials, computer or microprocessor software
- Patented materials, equipment, devices or processes
- License requirements

The Agency shall protect proprietary information provided by the Contractor to the fullest extent of the law. The Contractor shall grant a non-exclusive license to allow the Agency to utilize such information in order to maintain the vehicles. In the event that the Contractor no longer provides the information, the Agency has the right to reverse engineer patented parts and software.

The Agency reserves a royalty-free, non-exclusive and irrevocable license to reproduce, publish or otherwise use, and to authorize others to use, the following subject data for its purposes: (1) any subject data required to be developed and first produced in the performance of the Contract and specifically paid for as such under the Contract, whether or not a copyright has been obtained; and (2) any rights of copyright to which the Contractor, Subcontractor or Supplier purchases ownership for the purpose of performance of the Contract and specifically paid for as such under the Contract. The Contractor agrees to include the requirements of this clause, modified as necessary to identify the affected parties, in each subcontract and supply order placed under the Contract.

### **GC 7.2 Access to Onboard Operational Data**

The Agency grants to the Contractor the right to inspect, examine, download, and otherwise obtain any information or data available from components provided by the Contractor, including, but not limited to, any electronic control modules or other data-collection devices, to the extent necessary to enable the Contractor to perform reliability maintenance analysis, corrective action and/or other engineering type Work for the bus. This right expressly excludes access to information or data collected on any equipment not provided and installed by the Contractor.

## **GC 8. Changes**

### **GC 8.1 Contractor Changes**

Any proposed change in this Contract shall be submitted to the Agency for its prior approval. Oral change orders are not permitted. No change in this Contract shall be made without the prior written approval of the Procurement/Contracts Administrator. The Contractor shall be liable for all costs resulting from, and/or for satisfactorily correcting, any specification change not properly ordered by written modification to the Contract and signed by the Procurement/Contracts Administrator.

### **GC 8.2 Agency Changes**

The Agency may obtain changes to the Contract by notifying the Contractor in writing. As soon as reasonably possible but no later than thirty (30) calendar days after receipt of the written change order to modify the Contract, the Contractor shall submit to the Procurement/Contracts Administrator a detailed price and schedule Proposal for the Work to be performed. This Proposal shall be accepted or modified by negotiations between the Contractor and the Procurement/Contracts Administrator. At that time, a detailed modification shall be executed in writing by both parties. Disagreements that cannot be resolved within negotiations shall

be resolved in accordance with “Disputes,” below. Regardless of any disputes, the Contractor shall proceed with the Work ordered.

## **GC 9. Legal Clauses**

### **GC 9.1 Indemnification**

**GC 9.1.1**The Contractor shall, to the extent permitted by law:(1) protect, indemnify and save the Agency and its officers, employees and agents, including consultants, harmless from and against any and all liabilities, damages, claims, demands, liens, encumbrances, judgments, awards, losses, costs, expenses and suits or actions or proceedings, including reasonable expenses, costs and attorneys’ fees incurred by the Agency and its officers, employees and agents, including consultants, in the defense, settlement or satisfaction thereof, for any injury, death, loss or damage to persons or property of any kind whatsoever, arising out of or resulting from the intentional misconduct or negligent acts, errors or omissions of the Contractor in the performance of the Contract, including intentional misconduct, negligent acts, errors or omissions of its officers, employees, servants, agents, Subcontractors and Suppliers; and (2) upon receipt of notice and if given authority, shall settle at its own expense or undertake at its own expense the defense of any such suit, action or proceeding, including appeals, against the Agency and its officers, employees and agents, including consultants, relating to such injury, death, loss or damage. Each party shall promptly notify the other in writing of the notice or assertion of such claim, demand, lien, encumbrance, judgment, award, suit, action or other proceeding hereunder. The Contractor shall have sole charge and direction of the defense of such suit, action or proceeding. The Agency shall not make any admission that might be materially prejudicial to the Contractor unless the Contractor has failed to take over the conduct of any negotiations or defense within a reasonable time after receipt of the notice and authority above provided. The Agency shall at the request of the Contractor furnish to the Contractor all reasonable assistance that may be necessary for the purpose of defending such suit, action or proceeding, and shall be repaid all reasonable costs incurred in doing so. The Agency shall have the right to be represented therein by advisory council of its own selection at its own expense.

**GC 9.1.2**The obligations of the Contractor under the above paragraph shall not extend to circumstances where the injury, death or damages are caused solely by the negligent acts, errors or omissions of the Agency, its officers, employees, agents or consultants, including, without limitation, negligence in:(1) the preparation of the Contract documents, or (2) the giving of directions or instructions with respect to the requirements of the Contract by written order. The obligations of the Contractor shall not extend to circumstances where the injury, death or damages are caused, in whole or in part, by the negligence of any third-party operator, not including an assignee or Subcontractor of the Contractor, subject to the right of contribution. In case of joint or concurrent negligence of the parties giving rise to a claim or loss against either one or both, each shall have full rights of contribution from the other.

### **GC 9.2 Suspension of Work**

**GC 9.2.1** The Agency may at any time and for any reason within its sole discretion issue a written order to the Contractor suspending, delaying or interrupting all or any part of the Work for a specified period of time.

**GC 9.2.2**The Contractor shall comply immediately with any such written order and take all reasonable steps to minimize costs allocable to the Work covered by the suspension during the period of work stoppage. Contractor shall continue the Work that is not included in the suspension and shall continue such ancillary activities as are not suspended. The Contractor shall resume performance of the suspended Work upon expiration of the notice of suspension, or upon direction from the Agency.

**GC 9.2.3** The Contractor shall be allowed an equitable adjustment in the Contract price (excluding profit) and/or an extension of the Contract time, to the extent that cost or delays are shown by the Contractor to be

directly attributable to any suspension. However, no adjustment shall be made under this section for any suspension, delay or interruption due to the fault or negligence of the Contractor, or for which an equitable adjustment is provided for, or excluded under any other term or condition of the Contract. As soon as reasonably possible but no later than forty-five (45) calendar days, or any other period of time agreed to by the parties, after receipt of the written suspension of work notice, the Contractor shall submit to the Procurement/Contracts Administrator a detailed price and schedule Proposal for the suspension, delay or interruption.

### **GC 9.3 Excusable Delays/Force Majeure**

**GC 9.3.1** If the Contractor is delayed at any time during the progress of the Work by the neglect or failure of the Agency or by a cause as described below, then the time for completion and/or affected delivery date(s) shall be extended by the Agency subject to the following cumulative conditions:

- a. The cause of the delay arises after the Notice of Award and neither was nor could have been anticipated by the Contractor by reasonable investigation before such award. Such cause may also include force majeure events such as any event or circumstance beyond the reasonable control of the Contractor, including but not limited to acts of God; earthquake, flood and any other natural disaster; civil disturbance, strikes and labor disputes; fires and explosions; war and other hostilities; embargo; or failure of third parties, including Suppliers or Subcontractors, to perform their obligations to the Contractor;
- b. The Contractor demonstrates that the completion of the Work and/or any affected deliveries will be actually and necessarily delayed;
- c. The Contractor has taken measures to avoid and/or mitigate the delay by the exercise of all reasonable precautions, efforts and measures, whether before or after the occurrence of the cause of delay; and
- d. The Contractor makes written request and provides other information to the Agency as described in paragraph GC 9.3.4 below.

A delay in meeting all of the conditions of this section shall be deemed an excusable delay. Any concurrent delay that does not constitute an excusable delay shall not be the sole basis for denying a request hereunder.

**GC 9.3.2** None of the above shall relieve the Contractor of any liability for the payment of any liquidated damages owing from a failure to complete the Work by the time for completion that the Contractor is required to pay pursuant to “Liquidated Damages for Late Delivery of the Bus” for delays occurring prior to, or subsequent to the occurrence of an excusable delay.

**GC 9.3.3** The Agency reserves the right to rescind or shorten any extension previously granted, if subsequently the Agency determines that any information provided by the Contractor in support of a request for an extension of time was erroneous; provided, however, that such information or facts, if known, would have resulted in a denial of the request for an excusable delay. Notwithstanding the above, the Agency will not rescind or shorten any extension previously granted if the Contractor acted in reliance upon the granting of such extension and such extension was based on information that, although later found to have been erroneous, was submitted in good faith by the Contractor.

**GC 9.3.4** No extension or adjustment of time shall be granted unless: (1) written notice of the delay is filed with the Agency within fourteen (14) calendar days after the commencement of the delay and (2) a written application therefore, stating in reasonable detail the causes, the effect to date and the probable future effect on the performance of the Contractor under the Contract, and the portion or portions of the Work affected, is filed by the Contractor with the Agency within thirty (30) calendar days after the commencement of the delay. No such extension or adjustment shall be deemed a waiver of the rights of either party under this Contract. The Agency shall make its determination within thirty (30) calendar days after receipt of the application.

## **GC 9.4 Termination**

### **GC 9.4.1. Termination for Convenience**

The performance of Work under this Contract may be terminated by the Agency in accordance with this clause in whole, or from time to time in part, whenever the Procurement/Contracts Administrator shall determine that such termination is in the best interest of the Agency. Any such termination shall be effected by delivery to the Contractor of a notice of termination specifying the extent to which performance of Work under the Contract is terminated, and the date upon which such termination becomes effective.

After receipt of a notice of termination, and except as otherwise directed by the Procurement/Contracts Administrator, the Contractor shall do the following:

- Stop Work under the Contract on the date and to the extent specified in the notice of termination.
- Place no further orders or subcontracts for materials, services or facilities, except as may be necessary for completion of such portion of the Work under the Contract as is not terminated.
- Terminate all orders and subcontracts to the extent that they relate to the performance of work terminated by the notice of termination; assign to the Agency in the manner, at the times, and to the extent directed by the Procurement/Contracts Administrator, all of the right, title and interest of the Contractor under the orders and subcontracts so terminated, in which case the Agency shall have the right, in its discretion, to settle or pay any or all claims arising out of the termination of such orders and subcontracts.
- Settle all outstanding liabilities and all claims arising out of such termination of orders and subcontracts, with the approval or ratification of the Procurement/Contracts Administrator, to the extent he or she may require, which approval or ratification shall be final for all the purposes of this clause.
- Transfer title to the Agency and deliver in the manner, at the times and to the extent, if any, directed by the Procurement/Contracts Administrator the fabricated or unfabricated parts, Work in process, completed Work, supplies and other material produced as part of, or acquired in connection with the performance of, the Work terminated, and the completed or partially completed plans, drawings, information and other property which, if the Contract had been completed, would have been required to be furnished to the Agency.
- Use its best efforts to sell, in the manner, at the times, to the extent, and at the price(s) directed or authorized by the Procurement/Contracts Administrator, any property of the types referred to above, provided, however, that the Contractor shall not be required to extend credit to any purchaser, and may acquire any such property under the conditions prescribed by and at prices approved by the Procurement/Contracts Administrator, and provided further that the proceeds of any such transfer or disposition shall be applied in reduction of any payments to be made by the Agency to the Contractor under this Contract or shall otherwise be credited to the price or cost of the Work covered by this Contract or paid in such other manner as the Procurement/Contracts Administrator may direct.
- Complete performance of such part of the Work as shall not have been terminated by the notice of termination.
- Take such action as may be necessary, or as the Procurement/Contracts Administrator may direct, for the protection or preservation of the property related to this Contract that is in the possession of the Contractor and in which the Agency has or may acquire an interest.

The Contractor shall be paid its costs, including Contract close-out costs, and profit on Work performed up to the time of termination. The Contractor shall promptly submit its termination claim to the Agency to be paid the Contractor. Settlement of claims by the Contractor under this termination for convenience clause shall be in accordance with the provisions set forth in Part 49 of the Federal Acquisition Regulations (48 CFR 49) except that wherever the word “Government” appears, it shall be deleted and the word “Agency” shall be substituted in lieu thereof.

### **GC 9.4.2. Termination for Default**

The Agency may, by written notice of default to the Contractor, terminate the whole or any part of this Contract if the Contractor fails to make delivery of the supplies or to perform the services within the time specified herein or any extension thereof; or if the Contractor fails to perform any of the other material provisions of the Contract, or so fails to make progress as to endanger performance of this Contract in accordance with its terms, and in either of these two circumstances does not cure such failure within a period of ten (10) business days, or such longer period as the Procurement/Contracts Administrator may authorize in writing, after receipt of notice from the Procurement/Contracts Administrator specifying such failure.

If the Contract is terminated in whole or in part for default, the Agency may procure, upon such terms and in such manner as the Procurement/Contracts Administrator may deem appropriate, supplies or services similar to those so terminated. The Contractor shall be liable to the Agency for any excess costs for such similar supplies or services and shall continue the performance of this Contract to the extent not terminated under the provisions of this clause.

Except with respect to defaults of Subcontractors, the Contractor shall not be liable for any excess costs if the failure to perform the Contract arises out of a cause beyond the control and without the fault or negligence of the Contractor. If the failure to perform is caused by the default of a Subcontractor, and if such default arises out of causes beyond the control of both the Contractor and Subcontractor, and without the fault or negligence of either of them, the Contractor shall not be liable for any excess costs for failure to perform, unless the supplies or services to be furnished by the Subcontractor were obtainable from other sources and in sufficient time to permit the Contractor to meet the required delivery schedule.

Payment for completed supplies delivered to and accepted by the Agency shall be at the Contract price. The Agency may withhold from amounts otherwise due the Contractor for such completed supplies such sum as the Procurement/Contracts Administrator determines to be necessary to protect the Agency against loss because of outstanding liens or claims of former lien holders.

If, after notice of termination of this Contract under the provisions of this clause, it is determined for any reason that the Contractor was not in default under the provisions of this clause, or that the default was excusable under the provisions of this clause, then the rights and obligations of the parties shall be the same as if the notice of termination had been issued pursuant to termination for convenience of the Agency.

### **GC 9.5 Compliance with Laws and Regulations**

The Contractor shall at all times comply with all applicable laws, regulations, policies, procedures and directives (together, the "Law"), including without limitation, FTA regulations, policies, procedures and directives, including those listed directly or by reference in the agreement between the Agency and FTA that funds any part of this Contract, as they may be amended or promulgated from time to time during the term of this Contract. Contractor's failure to so comply shall constitute a material breach of this Contract.

### **GC 9.6 Changes of Law**

Changes of Law that become effective after the Proposal due date may result in price changes. If a price adjustment is indicated, either upward or downward, it shall be negotiated between the Agency and the Contractor, and the final Contract price will be adjusted upward or downward to reflect such changes in Law. Such price adjustment may be audited, where required.

### **GC 9.7 Governing Law and Choice of Forum**

This Contract shall be governed by the laws of South Carolina without regard to conflict of law rules. The Contractor consents to the jurisdiction of the identified state, County of Charleston.

## GC 9.8 Disputes

Except as otherwise provided in this Contract, any dispute concerning a question of fact arising under or related to this Contract that is not disposed of by agreement shall be decided in accordance with the following steps. However, by mutual agreement the matter may be taken immediately to any higher step in the dispute resolution process, or a mutually agreed-to alternative dispute resolution process (which may include structured negotiations, mediation or arbitration) or litigation. Pending final resolution of a dispute hereunder, the Contractor shall proceed diligently with the performance of the Contract and in accordance with the Procurement/Contracts Administrator's or Executive Director Officer's decision, as the case may be.

1. **Notice of dispute.** All disputes shall be initiated through a written dispute notice submitted by either party to the other party within 10 (ten) calendar days of the determination of the dispute.
2. **Negotiation between Procurement/Contracts Administrators.** The parties shall attempt in good faith to resolve any dispute arising out of or relating to this Contract promptly by negotiation between executives who have authority to settle the controversy and who are at a higher level of management than the people with direct responsibility for administration of this Contract. Any party may give the other party written notice of any dispute not resolved in the normal course of business as provided in paragraph 1 above. Within 14 (fourteen) calendar days after delivery of the dispute notice, the receiving party shall submit to the other party a written response. The dispute notice and written response shall include: (a) a statement of the party's position and a summary of the arguments supporting that position, (b) any evidence supporting the party's position and (c) the name of the executive who will represent that party and of any others who will accompany the executive in negotiations. Within 28 (twenty-eight) calendar days after delivery of the dispute notice, the Procurement/Contracts Administrator of both parties shall meet at a mutually acceptable time and place, and thereafter as they reasonably deem necessary to attempt to resolve the dispute. All reasonable requests for information by one party to the other shall be honored.

If the matter has not been resolved by these people within 42 (forty-two) calendar days of the dispute notice, the dispute may be referred to more senior executives of both parties who have authority to settle the dispute and who shall likewise meet to attempt to resolve the dispute.

3. **Executive Director's decision.** Should the dispute not be resolved by negotiation between Procurement/Contracts Administrators, as provided in paragraph 2 above, the Agency's Procurement/Contracts Administrator from paragraph 2 above shall submit a written request for decision to the Agency's Executive Director along with all documentation and minutes from the negotiations. The Executive Director shall issue a written decision within 14 (fourteen) days of receipt of a request.
  - A. For disputes involving \$50,000 or less, the decision of the Executive Director shall be administratively final and conclusive. For disputes involving \$50,000 or less, it is the intent of the parties that such administratively final and conclusive decision pursuant to either this paragraph or paragraph 4 shall be overturned only if determined by a court of competent jurisdiction to be fraudulent, arbitrary, capricious, unsupported by the evidence or so grossly erroneous as to imply bad faith. For disputes greater than \$50,000, the decision of the Executive Director shall be administratively final and conclusive unless, within thirty (30) days from the date of delivery of the written decision, the Contractor appeals the decision in writing to the Agency's Executive Director Officer or designee, who shall render a written decision within fourteen (14) days of delivery of such written appeal. Such decision by the Executive Director or his or her designee shall be administratively final and conclusive.

- B. Within thirty (30) days of the issuance of any administratively final and conclusive decision under this paragraph, the Contractor shall notify the Agency in writing of the Contractor's agreement with the final decision. Failure to provide such written notice of agreement shall indicate an intent by the Contractor to litigate the claim.
  - C. Any dispute that is not resolved by the parties through the operation of the provisions of this paragraph, or any mutually agreed-upon alternative disputes resolution process pursuant to paragraph 4, may be submitted to any court in South Carolina.
  - D. Pending final resolution of a dispute hereunder, the Contractor shall proceed diligently with the performance of its obligations under the Contract in accordance with the written directions of the Agency.
- 4. **Alternatives disputes resolution.** If agreed to by both parties, disputes may be resolved by a mutually agreed-to alternative dispute resolution process that may include structured negotiations different from paragraph 2 above, mediation or arbitration.
  - 5. **Arbitration.** Disputes appealed to arbitration involving more than \$50,000 but less than \$250,000 shall be decided by a qualified and disinterested arbitrator, selected through the American Arbitration Association and mutually agreed to by both parties. The arbitrator shall conduct all proceedings in accordance with the rules of the American Arbitration Association and shall consider the Contract, equity, the prevailing law and established commercial practices in rendering a decision.

Disputes appealed to arbitration involving \$250,000 or more shall be decided by three (3) qualified and disinterested arbitrators selected through the American Arbitration Association. One arbitrator shall be selected by each of the parties, and the two selected arbitrators shall select a third arbitrator within ten (10) calendar days of their selection. The arbitrators shall conduct all proceedings in accordance with the rules of the American Arbitration Association and shall consider the Contract, equity, the prevailing law and established commercial practice in rendering a decision. The decision of the arbitrators shall not be binding, and either party shall have the right to remedies provided by law.

## **GC 9.9 Maintenance of Records; Access by Agency; Right to Audit Records**

In accordance with 49 CFR § 18.36(i), 49 CFR § 19.48(d) and 49 USC § 5325(a), provided that the Agency is the FTA recipient or a sub-grantee of the FTA recipient, the Contractor agrees to provide the Agency, FTA, the Comptroller General of the United States, the Secretary of the U.S. Department of Transportation, South Carolina or any of their duly authorized representatives access to any books, documents, papers and records of the Contractor that are directly pertinent to or relate to this Contract (1) for the purpose of making audits, examinations, excerpts and transcriptions and (2) when conducting an audit and inspection.

- 1. In the event of a sole-source Contract, single Proposal, single responsive Proposal, or competitive negotiated procurement, the Contractor shall maintain and the Contracting Officer, the U.S. Department of Transportation (if applicable) or the representatives thereof shall have the right to examine all books, records, documents and other cost and pricing data related to the Contract price, unless such pricing is based on adequate price competition, established catalog or market prices of commercial items sold in substantial quantities to the public, or prices set by law or regulation, or combinations thereof. Data related to the negotiation or performance of the Contract shall be made available for the purpose of evaluating the accuracy, completeness and currency of the cost or pricing data. The right of examination shall extend to all documents necessary for adequate evaluation of the cost or pricing data, along with the computations and projections used therein, including review of

accounting principles and practices that properly reflect all direct and indirect costs anticipated for the performance of the Contract.

2. For Contract modifications or change orders, the Contracting Officer, the U.S. Department of Transportation, if applicable, or their representatives shall have the right to examine all books, records, documents and other cost and pricing data related to a Contract modification, unless such pricing is based on adequate price competition, established catalog or market prices of commercial items sold in substantial quantities to the public, or prices set by law or regulation, or combinations thereof. Data related to the negotiation or performance of the Contract modification or change order shall be made available for the purpose of evaluating the accuracy, completeness and currency of the cost or pricing data. The right of examination shall extend to all documents necessary for adequate evaluation of the cost or pricing data, along with the computations and projections used therein, either before or after execution of the Contract modification or change order for the purpose of conducting a cost analysis. If an examination made after execution of the Contract modification or change order reveals inaccurate, incomplete or out-of-date data, the Contracting Officer may renegotiate the Contract modification or change order price adjustment, and the Agency shall be entitled to any reductions in the price that would result from the application of accurate, complete or up-to-date data.

The requirements of this section are in addition to other audit, inspection and record-keeping provisions specified elsewhere in the Contract documents.

## **GC 9.10 Confidential Information**

Access to government records is governed by the State of South Carolina. Except as otherwise required by the law, the Agency will exempt from disclosure proprietary information, trade secrets and confidential commercial and financial information submitted or disclosed during the Contract period. Any such proprietary information, trade secrets or confidential commercial and financial information that a Contractor believes should be exempted from disclosure shall be specifically identified and marked as such. Blanket-type identification by designating whole pages or sections as containing proprietary information, trade secrets or confidential commercial and financial information will not ensure confidentiality. The specific proprietary information, trade secrets or confidential commercial and financial information must be clearly identified as such.

Upon a request for records from a third party regarding the Contract, the Agency will notify the Contractor in writing. The Contractor must respond within twenty (20) days with the identification of any and all “proprietary, trade secret or confidential commercial or financial” information, and the Contractor shall indemnify the Agency’s defense costs associated with its refusal to produce such identified information; otherwise, the requested information may be released.

The Agency shall employ sound business practices no less diligent than those used for the Agency’s own confidential information to protect the confidence of all licensed technology, software, documentation, drawings, schematics, manuals, data and other information and material provided by the Contractor pursuant to the Contract that contain confidential commercial or financial information, trade secrets or proprietary information as defined in or pursuant to the State of South Carolina against disclosure of such information and material to third parties except as permitted by the Contract. The Contractor shall be responsible for ensuring that confidential commercial or financial information, trade secrets or proprietary information, with such determinations to be made by the Agency at its sole discretion, bears appropriate notices relating to its confidential character.

During the performance of the Work under the Contract, it may be necessary for either party (the “Discloser”) to make confidential information available to the other party (the “Recipient”). The Recipient agrees to use all



such information solely for the performance of the Work under the Contract and to hold all such information in confidence and not to disclose same to any third party without the prior written consent of the Discloser. Likewise, the Recipient agrees that all information developed in connection with the Work under the Contract shall be used solely for the performance of the Work under the Contract, and shall be held in confidence and not disclosed to any third party without the prior written consent of the Discloser.

This Confidentiality section shall survive the termination or expiration of the Contract.

### **GC 9.11 Conflicts of Interest, Gratuities**

No member, officer, or employee of the Agency or of a local public body during his or her tenure, or one year thereafter, shall have any interest, direct or indirect, in this Contract or the proceeds thereof.

### **GC 9.12 General Nondiscrimination Clause**

In connection with the performance of Work provided for under this Contract, the Contractor agrees that it will not, on the grounds of race, religious creed, color, national origin, ancestry, physical disability, medical condition, marital status, sex, sexual orientation or age, discriminate or permit discrimination against any person or group of people in any manner prohibited by federal, state or local laws.

### **GC 9.13 Amendment and Waiver**

#### **GC 9.13.1. Amendment**

Any modification or amendment of any provisions of any of the Contract documents shall be effective only if in writing, signed by authorized representatives of both the Agency and Contractor, and specifically referencing this Contract.

#### **GC 9.13.2. Waiver**

In the event that either party elects to waive its remedies for any breach by the other party of any covenant, term or condition of this Contract, such waiver shall not limit the waiving party's remedies for any succeeding breach of that or of any other term, covenant or condition of this Contract.

### **GC 9.14 Remedies Not Exclusive**

The rights and remedies of the Agency provided herein shall not be exclusive and are in addition to any other rights and remedies provided by law or under the Contract.

### **GC 9.15 Counterparts**

This Contract may be executed in any number of counterparts. All such counterparts shall be deemed to constitute one and the same instrument, and each of said counterparts shall be deemed an original thereof.

### **GC 9.16 Severability**

Whenever possible, each provision of the Contract shall be interpreted in a manner as to be effective and valid under applicable law. However, if any provision, or part of any provision, should be prohibited or invalid under applicable law, then such provision, or part of such provision, shall be ineffective to the extent of such prohibition or invalidity without invalidating the remainder of such provision or the remaining provisions of the Contract.

### **GC 9.17 Third-Party Beneficiaries**

No provisions of the Contract shall in any way inure to the benefit of any third party, including the public at large, so as to constitute such person a third-party beneficiary of the Contract or of any one or more of the

terms and conditions of the Contract or otherwise give rise to any cause of action in any person not a party to the Contract, except as expressly provided elsewhere in the Contract.

### **GC 9.18 Assignment of Contract**

Neither party will assign or subcontract its rights or obligations under the Contract without prior written permission of the other party, and no such assignment or subcontract will be effective until approved in writing by the other party.

### **GC 9.19 Independent Parties**

The Contractor is an independent contractor with respect to the performance of all Work hereunder, retaining control over the detail of its own operations, and the Contractor shall not be considered the agent, employee, partner, fiduciary or trustee of the Agency.

### **GC 9.20 Survival**

The following sections shall survive the nominal expiration or discharge of other Contract obligations, and the Agency may obtain any remedy under law, Contract or equity to enforce the obligations of the Contractor that survive the manufacturing, warranty and final payment periods:

- “Intellectual Property Warranty”
- “Data Rights”
- “Indemnification”
- “Governing Law and Choice of Forum”
- “Disputes”
- “Confidential Information”
- “Parts Availability Guarantee”
- “Access to Records”
- “Training”

## SECTION 4: SPECIAL PROVISIONS

### SP 1. Inspection, Tests and Repairs

#### SP 1.1 Repair Performance

##### SP 1.1.1 Repairs by Contractor

After non-acceptance of the bus, the Contractor must begin Work within five (5) working days after receiving notification from the Agency of failure of acceptance tests. The Agency shall make the bus available to complete repairs timely with the Contractor repair schedule.

The Contractor shall provide, at its own expense, all spare parts, tools and space required to complete the repairs. At the Agency's option, the Contractor may be required to remove the bus from the Agency's property while repairs are being made. If the bus is removed from the Agency's property, then repair procedures must be diligently pursued by the Contractor's representatives, and the Contractor shall assume risk of loss while the bus is under its control.

##### SP 1.1.2 Repairs by the Agency

The Agency will not take responsibility to correct Defects, except to replace defective parts as instructed by the Contractor.

1. **Parts used.** If the Agency performs the repairs after non-acceptance of the bus, it shall correct or repair the Defect and any Related Defects using Contractor-specified parts available from its own stock or those supplied by the Contractor specifically for this repair. reports of all repairs covered by this procedure shall be submitted by the Agency to the Contractor for reimbursement or replacement of parts monthly, or at a period to be mutually agreed upon. The Contractor shall provide forms for these reports.
2. **Contractor-supplied parts.** If the Contractor supplies parts for repairs being performed by the Agency after non-acceptance of the bus, then these parts shall be shipped prepaid to the Agency.
3. **Return of defective components.** The Contractor may request that parts covered by this provision be returned to the manufacturing plant. The total costs for this action shall be paid by the Contractor.
4. **Reimbursement for labor.** The Agency shall be reimbursed by the Contractor for labor. The amount shall be determined by the Agency for a qualified mechanic at a straight time wage rate, which includes fringe benefits and overhead adjusted for the Agency's most recently published rate in effect at the time the Work is performed, plus the cost of towing in the bus, if such action was necessary. These wage and fringe benefits rates shall not exceed the rates in effect in the Agency's service garage at the time the Defect correction is made.
5. **Reimbursement for parts.** The Agency shall be reimbursed by the Contractor for defective parts that must be replaced to correct the Defect. The reimbursement shall include taxes where applicable.

#### SP 1.2 Configuration and Performance Approval

In order to assess the Contractor's compliance with the Technical Specifications, the Agency and the Contractor shall, at the Pre-Production Meeting, jointly develop a configuration and performance review document for review of the pilot vehicle. This document shall include appropriate performance standards for each test that is being required, and the document shall become part of the official record of the Pre-Production Meeting.

### **SP 1.3 First Article Inspection – Production**

The purpose of a first article inspection is to confirm that any components, systems, subsystems, major assemblies, subassemblies, products, parts, apparatuses, articles and other materials comply with the Technical Specifications and other Contract documents.

Where required by the Contract documents or requested by the Agency, the Contractor shall cause first article inspections to be conducted. A first article inspection may include both a physical configuration inspection and a functional demonstration. First article inspections shall be conducted at the Contractor or Subcontractor's facility. The Contractor shall furnish to the Agency prior to each first article inspection a written inspection and demonstration plan for each item for review. The Agency's inspectors will attend each first article inspection unless the Agency provides a written waiver of its right to attend any such inspection. The results of each first article inspection shall be documented by the Contractor in a format deemed acceptable by the Agency, and all documents relating to the inspection shall be forwarded to the Agency.

### **SP 1.4 Post-Delivery Tests**

The Agency will conduct acceptance tests on each delivered bus. These tests shall be completed within thirty (30) days after bus delivery and shall be conducted in accordance with written test plans. The purpose of these tests is to identify Defects that have become apparent between the time of bus release and delivery to the Agency. The post-delivery tests shall include visual inspection and bus operations. No post-delivery test shall apply criteria that are different from the criteria applied in an analogous pre-delivery test (if any).

Buses that fail to pass the post-delivery tests are subject to non-acceptance. The Agency shall record details of all Defects on the appropriate test forms and shall notify the Contractor of acceptance or non-acceptance of each bus according to "Inspection, Testing and Acceptance" after completion of the tests. The Defects detected during these tests shall be repaired according to the procedures defined in "Repairs after Non-Acceptance."

### **SP 1.5 Repairs after Non-Acceptance**

The Contractor, or its designated representative, shall perform the repairs after non-acceptance. If the Contractor fails or refuses to begin the repairs within five (5) days, then the Work may be done by the Agency's personnel with reimbursement by the Contractor.

## **SP 2. Deliveries**

### **SP 2.1 Bus Delivery**

Delivery of buses shall be determined by signed receipt of the Agency's designated agent(s), CARTA 3664 Leeds Ave. North Charleston, SC 29405, at the following point(s) of delivery and may be preceded by a cursory inspection of the bus.

### **SP 2.2 Delivery Schedule**

Hours of delivery shall be 8:00 AM – 3:00 PM on the following days of the week: Monday - Friday

### **SP 2.3 Contract Deliverables**

Contract deliverables associated with this Contract are set forth in the table below, along with other pertinent information. Contract deliverables shall be submitted in accordance with "Section 6: Technical Specifications." Due dates shown note the last acceptable date for receipt of Contract deliverables. The Agency will consider early receipt of Contract deliverables on a case-by-case basis. The reference section designates the appropriate specification section(s) where the requirement is referenced.

**TABLE 1**  
Contract Deliverables

Deliverable		Agency Action	Reference Section	Due Date	Format	Quantity Due
1.	Bus Testing— Altoona Test Report	Review		Prior to 1st delivery	Hardcopy	1
2.	List of serialized units installed on each bus	Review		With each delivered bus	Electronic media	1 per bus
3.	Copy of Manufacturers' formal Quality Assurance Program	Review		Pre-award site visit	Hardcopy	1
4.	QA manufacturing certificate	Review		With each delivered bus	Hardcopy	1 per bus
5.	QA purchasing certifications acknowledging receipt of applicable specification	Review		30 days following first Pre-Production Meeting	Hardcopy	1 per major Supplier
6.	Pre-Delivery Bus Documentation Package	Review		With each delivered bus	Hardcopy	1 per bus
7.	Motor Vehicle Pollution Requirements Certificate	Review		With each bus	Hardcopy	1
8.	Engine Emissions Certificate—NOx levels	Review		Prior to completion of 1st bus	Hardcopy	1
9.	Pre-Production Meeting minutes	Approval		30 days after each meeting	Hardcopy	2 originals
10.	Driver's log and incident report	Review		With each bus delivery if drive-away service is used	Hardcopy	1 per bus
11.	Title documentation	Review		10 days prior to bus delivery	Hardcopy	1 per bus
12.	Performance bond	Review		30 days following execution of Contract	Hardcopy	1
13.	Insurance certificates	Approval		Before Work commences	Hardcopy	1
14.	Engineering support	Review		During Pre-Production Meeting	Contracts	1
15.	Training instructor information	Approval		30 days prior to delivery of pilot bus		
16.	Training curriculum	Approval		30 days prior to delivery of pilot bus	Electronic media	
17.	Teaching materials	Review		During classroom instruction	Hardcopy	1
18.	Professionally prepared mechanics' "Bus Orientation" training video	Review		30 days prior to first production bus	Electronic Media	20 each
19.	Final preventative maintenance manuals	Review		90 days after Agency written approval	Hardcopy  Electronic media	3
20.	Final diagnostic procedures manuals	Review		90 days after Agency written approval	Hardcopy  Electronic media	3

**TABLE 1**  
Contract Deliverables

	<b>Deliverable</b>	<b>Agency Action</b>	<b>Reference Section</b>	<b>Due Date</b>	<b>Format</b>	<b>Quantity Due</b>
21.	Final parts manuals	Approval		90 days after Agency written approval	Hardcopy Electronic media	2
22.	Component repair manuals (Agency approval/review period of 90 days from date of receipt)	Approval		90 days after Agency written approval of OEM component repair list	Hardcopy Electronic media	2 2
23.	Draft preventative maintenance manuals (Agency approval/review period of 90 days from date of receipt)	Approval		With 1 <sup>st</sup> Bus	Hardcopy	10
24.	Draft diagnostic procedures manuals (Agency approval/review period of 90 days from date of receipt)	Approval		With 1 <sup>st</sup> Bus	Hardcopy	10
25.	Draft parts manuals (Agency approval/review period of 90 days from date of receipt)	Approval		With 1 <sup>st</sup> Bus	Hardcopy	10
26.	List of OEM component repair manuals	Approval		With 1 <sup>st</sup> Bus	Hardcopy	10
27.	Draft operators' manuals (Agency approval/review period of 90 days from date of receipt)	Approval		With 1 <sup>st</sup> bus or maximum of 30 days prior to start of production	Hardcopy	10
28.	Final operators' manuals	Review		30 days following Agency approval of draft manual	Hardcopy	1 per bus
29.	Recommended spare parts list, including bill of materials	Review		60 days prior to shipment of first bus	Hardcopy	1
30.	Part number index	Approval		60 days prior to shipment of first bus	Hardcopy Spreadsheet	1 1
31.	Current price list	Review		90 days after Agency written approval of draft parts manual	Hardcopy	20
32.	In-process drawings	Review		30 days prior to production	Scale drawings	1
33.	Electrical and air schematics	Review		30 days prior to production	Hardcopy	1
34.	As-built drawings	Review		Within 60 days after final bus delivery	Electronic media	1
35.	Material samples	Review		By conclusion of Pre-Production Meetings		1
36.	Undercoating system program	Approval		First Pre-Production Meeting	Hardcopy	1
37.	Flooring certificate	Review		First Pre-Production Meeting	Certificate/ copy of purchase order	1

**TABLE 1**  
Contract Deliverables

	<b>Deliverable</b>	<b>Agency Action</b>	<b>Reference Section</b>	<b>Due Date</b>	<b>Format</b>	<b>Quantity Due</b>
38.	Interior features – fire-resistance certificates	Review		Prior to pilot bus completion	Certificates	1
39.	Crashworthiness	Review		Pre-award audit	Certificate	1
40.	Technical review of electronic functionality	Approval		Prior to production	Hardcopy	1
41.	Interior security camera layout	Approval		Prior to pilot bus completion	Copies of interior views	1 each
42.	Technical review of power plant			Prior to production		
43.	Power plant certifications	Review		Prior to pilot bus completion	Hardcopy	1 each
44.	Striping layout	Approval		Prior to production	Hardcopy	1
45.	Resolution of issues “subject to Agency approval”	Approval		Prior to production	Hardcopy	1

### **SP 3. Options and Option Pricing**

The Contractor hereby grants the Agency and any permissible assignee options (“Options”) to purchase up to twenty-five (25) additional vehicles (“Option Vehicles”) and any associated components for a period of five (5) years from the effective date of the Contract. There shall be no minimum order quantity for any permissible assignee. Subject to the Agency’s right to order modifications, the Option Vehicles shall have the same specifications as the vehicles purchased under this Contract. The Agency may exercise the Options by written notice to the Contractor (“Notice of Exercise of Option”) at any time on or before five (5) years following the effective date of the Contract (“Option Date”).

The price of the Option Vehicles shall be the unit price of the base order vehicles, (“Base Order Price”) adjusted by multiplying the base order price by the following fraction:

The Index shall be the Producer Price Index for Truck and Bus Bodies, Series No. 1413, published by the United States Department of Labor, Bureau of Labor Statistics, or if such Index is no longer in use, then such replacement that is most comparable to the Index as may be designated by the Bureau of Labor Statistics, or as agreed by the parties.

Within thirty (30) days after delivery of the Notice of Exercise of Option to the Contractor, the Contractor shall submit a proposed delivery schedule. Along with the proposed delivery schedule, the Contractor will provide the Agency with access to its production schedule for the purpose of the parties verifying available production capacity. The production schedule shall include a reasonable time for mobilization and for coordinating with other vehicle orders, and it shall be based upon a production rate at least equal to the production rate actually realized with respect to the base order vehicles. If the parties are unable to agree on a production schedule, then the maximum term for the production of the Option Vehicles shall not exceed a total of twelve (12) months after the date of Notice to Proceed with Option Vehicle production. The Agency or any permissible assignee may issue a Notice to Proceed at any time after the Contractor submits its proposed delivery schedule. The Contractor shall not commence production of the Option Vehicles prior to issuance of the Notice to Proceed by the Agency or any permissible assignee of the Agency for the Option Vehicles incorporating the agreed production delivery schedule or the twelve (12) month maximum term.

Except as otherwise specially provided in this Contract, all other terms of the Contract shall apply to the Option Vehicles.

#### **SP 4. Assignability of Options**

If the Agency does not exercise the option(s) as listed in “Options and Option Pricing,” then the Agency reserves the right to assign the option(s) to other grantees of FTA funds in accordance with FTA Circular 4220.1F or its successors.

#### **SP 5. Payment**

The Agency shall pay and the Contractor shall accept the amounts set forth in the price schedule as full compensation for all costs and expenses of completing the Work in accordance with the Contract, including but not limited to all labor, equipment and material required; overhead; expenses; storage and shipping; risks and obligations; taxes (as applicable); fees and profit; and any unforeseen costs.

##### **SP 5.1 Payment Terms**

###### **Option 1: Payment upon Delivery**

All payments shall be made as provided herein, less any additional amount withheld as provided below and less any amounts for liquidated damages in accordance with “Liquidated Damages for Late Delivery of the Bus.”

The Agency shall make payments for buses at the unit prices itemized in the price schedule within forty-five (45) days after the delivery and acceptance of each bus and receipt of a proper invoice.

The Agency shall make payments for spare parts and/or equipment at the unit prices itemized in the price schedule within forty-five (45) calendar days after the delivery and acceptance of said spare parts and/or equipment and receipt of a proper invoice.

The Agency shall make a final payment for all withholding within forty-five (45) calendar days of receipt of a final proper invoice and the following:

1. Delivery and acceptance of all Contract deliverables, including manuals and other documentation required by the Contract, excluding training.
2. Contractor provision of any certifications as required by law and/or regulations.
3. Completion of post-delivery audits required under the Contract.

The Contractor may charge interest for late payment if payment is delayed more than ten (10) days after the payment Due Date set forth above. Interest will be charged at a rate not to exceed the prime rate of interest published by The Wall Street Journal on the 10th day.

##### **SP 5.2 Payment of Taxes**

Unless otherwise provided in this Contract, the Contractor shall pay all federal, state and local taxes, and duties applicable to and assessable against any Work, goods, services, processes and operations incidental to or involved in the Contract, including but not limited to retail sales and use, transportation, export, import, business and special taxes. The Contractor is responsible for ascertaining and paying the taxes when due. The total Contract price shall include compensation for all taxes the Contractor is required to pay by laws in effect on the Proposal Due Date. At the present time, the Agency asserts that the taxes applicable to this Contract are exempt. The Contractor will maintain auditable records, subject to the Agency reviews, confirming that tax payments are current at all times.



## **SP 6. Service and Parts**

### **SP 6.1 Contractor Service and Parts Support**

The Contractor shall state on the form Contractor Service and Parts Support Data the representatives responsible for assisting the Agency, as well as the location of the nearest distribution center, which shall furnish a complete supply of parts and components for the repair and maintenance of the buses to be supplied. The Contractor also shall state below, or by separate attachment, its policy on transportation charges for parts other than those covered by warranty.

### **SP 6.2 Documentation**

The Contractor shall provide an electronic copy and two (2) printed current maintenance manual(s) to include preventative maintenance procedures, diagnostic procedures or troubleshooting guides and major component service manuals, an electronic copy and two (2) printed current parts manual(s), and an electronic copy and two (2) printed standard operator's manual(s) as part of this Contract. The Contractor also shall exert its best efforts to keep maintenance manuals, operator's manuals and parts books up to date for a period of fifteen (15) years. The supplied manuals shall incorporate all equipment ordered on the buses covered by this procurement. In instances where copyright restrictions or other considerations prevent the Contractor from incorporating major components information into the bus parts and service manuals, separate manual sets as published by the subcomponent Supplier will be provided.

### **SP 6.3 Parts Availability Guarantee**

The Contractor hereby guarantees to provide, within reasonable periods of time, the spare parts, software and all equipment necessary to maintain and repair the buses supplied under this Contract for a period of at least twelve (12) years after the date of acceptance. Parts shall be interchangeable with the original equipment and shall be manufactured in accordance with the quality assurance provisions of this Contract. Prices shall not exceed the Contractor's then-current published catalog prices.

Where the parts ordered by the Agency are not received within two (2) working days of the agreed-upon time and date and a bus procured under this Contract is out of service due to the lack of said ordered parts, then the Contractor shall provide the Agency, within eight (8) hours of the Agency's verbal or written request, the original Suppliers' and/or manufacturers' parts numbers, company names, addresses, telephone numbers and contact persons' names for all of the specific parts not received by the Agency.

Where the Contractor fails to honor this parts guarantee or parts ordered by the Agency are not received within thirty (30) days of the agreed-upon delivery date, then the Contractor shall provide to the Agency, within seven (7) days of the Agency's verbal or written request, the design and manufacturing documentation for those parts manufactured by the Contractor and the original Suppliers' and/or manufacturers' parts numbers, company names, addresses, telephone numbers and contact persons' names for all of the specific parts not received by the Agency. The Contractor's design and manufacturing documentation provided to the Agency shall be for its sole use in regard to the buses procured under this Contract and for no other purpose.

### **SP 6.4 Agency-Furnished Property**

In the event that equipment or other goods or materials are specified in the Technical Specifications to be furnished by the Agency to the Contractor for incorporation in the Work, the following provisions shall apply:

The Agency shall furnish the equipment, goods or materials in a timely manner so as not to delay Contract delivery or performance dates. If Agency-furnished property is received in a condition not suitable for the intended use, then the Contractor shall promptly notify the Agency, detailing the facts, and at the Agency's expense repair, modify, return or take such other action as directed by the Agency. The parties may conduct a joint inspection of the property before the Contractor takes possession to document its condition.

The Agency retains title to all Agency-furnished property. Upon receipt of the Agency-furnished property, the Contractor assumes the charge and care of the property and bears the risk of loss or damage due to action of the elements or from any other cause. The Contractor shall provide appropriate protection for all such property during the progress of the Work. Should any Agency-furnished equipment or materials be damaged, such property shall be repaired or replaced at the Contractor's expense to the satisfaction of the Agency. No extension of time will be allowed for repair or replacement of such damaged items. Should the Contractor not repair or replace such damaged items, the Agency shall have the right to take corrective measures itself and deduct the cost from any sums owed to the Contractor.

Warranty administration and enforcement for Agency-furnished equipment are the responsibility of the Agency, unless the parties agree to transfer warranty responsibility to the Contractor.

### **SP 7. Federal Motor Vehicle Safety Standards (FMVSS)**

The Contractor shall submit one (1) manufacturer's FMVSS self-certification, Federal Motor Vehicles Safety Standards, that the vehicle complies with relevant FMVSS or two manufacturer's certified statement that the contracted buses will not be subject to FMVSS regulations.

### **SP 8. Insurance**

The Contractor shall maintain in effect during the term of this Contract, including any warranty period, at its own expense, at least the following coverage and limits of insurance:

- Statutory Workers Compensation and Employers Liability insurance and/or qualified self-insurance program covering Supplier's employees while on Agency property.
- Commercial General Liability Insurance:
  - Bodily Injury and Property Damage, including Contractual Liability covering the indemnification contained herein, \$10,000,000 combined single limits per occurrence, \$10,000,000 aggregate, where applicable.
  - Product liability: \$5,000,000 per occurrence, for a period of five (5) years after acceptance of the last bus delivered under this Contract (Products Liability coverage may be effected through one or more excess liability policies).
- Automobile Liability Insurance: Bodily Injury and Property Damage, \$1,000,000 combined single limits per occurrence.

Contractor shall deliver to the Agency, within ten (10) days after receiving Notice of Award of this Contract, evidence of the above. Prior to the expiration of any insurance during the time required, the Supplier shall furnish evidence of renewal to the Agency's Contract Administrator.

### **SP 9. Software Escrow Account**

All the Contractor's policies shall contain an endorsement naming the Agency as an additional insured and providing that written notice shall be given to the Agency's location at least thirty (30) days prior to termination, cancellation or material reduction of coverage in the policy; provided, however, that such notice may be given on ten (10) days' notice if the termination is due to nonpayment of premium.

Upon execution of the Contract, the Contractor shall provide the Agency a list of all OEM software comprising proprietary works ("Proprietary Software") for all major vehicle subsystems. From time to time and only upon request, information contained within the listed software may be made available to the Agency through the OEM of the vehicle subsystem. The Contractor and OEM are not obligated to provide copies of source code, as this is proprietary intellectual property; however, the Contractor is obligated to assist the Agency with any technical assistance for the duration of the life of the vehicle. It is the Agency's prerogative

to evaluate the long-term viability of the Contractor and its Subcontractors and Suppliers based upon the criteria set forth in “Qualification Requirements.”

## **SP 10. Sustainability**

The Agency recognizes that being sustainable (environmentally, economically and socially responsible) involves everyone, both internal and external to the Agency. The Agency expects its Contractors to have their own sustainability policies and programs in place and to provide services in line with the principles established therein. Implementation of sustainable practices may include maximizing the use of environmentally and socially responsible materials and services, utilizing energy-efficient and non-polluting vehicles, equipment and processes, and ensuring employee awareness of sustainability initiatives.

The Agency has a sustainability policy that includes the responsibility to make sure all of its Contractors are informed of this policy. The Contractor will provide the Agency with a statement indicating that responsible parties have read and understand the Agency’s sustainability policies and that it agrees to use reasonable efforts to conduct its work and operations in a manner that is consistent with them. In addition the Contractor will provide the Agency with a copy of its corporate sustainability policy.

## SECTION 5: FEDERAL REQUIREMENTS

### **FR 1. Access to Records**

The Contractor agrees to maintain all books, records, accounts and reports required under this Contract for a period of not less than three years after the date of termination or expiration of this Contract, except in the event of litigation or settlement of claims arising from the performance of this Contract, in which case Contractor agrees to maintain same until the Agency, the FTA Administrator, the Comptroller General or any of their duly authorized representatives have disposed of all such litigation, appeals, claims or exceptions related thereto. Reference 49 CFR 18.39(i)(11).

#### **FR 1.1 Local Governments**

In accordance with 49 CFR 18.36(i), the Contractor agrees to provide the Agency, the FTA Administrator, the Comptroller General of the United States or any of their authorized representatives access to any books, documents, papers and records of the Contractor that are directly pertinent to this Contract for the purposes of making audits, examinations, excerpts and transcriptions. Contractor also agrees, pursuant to 49 CFR 633.17 to provide the FTA Administrator or his authorized representatives including any PMO Contractor access to Contractor's records and construction sites pertaining to a major capital project, defined at 49 USC 5302(a)1, which is receiving federal financial assistance through the programs described at 49 USC 5307, 5309 or 5311.

#### **FR 1.2 State Governments**

In accordance with 49 CFR 633.17, the Contractor agrees to provide the Agency, the FTA Administrator or his authorized representatives, including any PMO Contractor, access to the Contractor's records and construction sites pertaining to a major capital project, defined at 49 USC 5302(a)1, which is receiving federal financial assistance through the programs described at 49 USC 5307, 5309 or 5311.

The Contractor agrees to permit any of the foregoing parties to reproduce by any means whatsoever or to copy excerpts and transcriptions as reasonably needed.

### **FR 2. Federal Funding, Incorporation of FTA Terms and Federal Changes**

The preceding provisions include, in part, certain standard terms and conditions required by the Department of Transportation, whether or not expressly set forth in the preceding Contract provisions. All contractual provisions required by DOT, as set forth in FTA Circular 4220.1F or its successors are hereby incorporated by reference. Anything to the contrary herein notwithstanding, all FTA mandated terms shall be deemed to control in the event of a conflict with other provisions contained in this agreement. The Contractor shall not perform any act, fail to perform any act or refuse to comply with any CARTA requests that would cause CARTA to be in violation of the FTA terms and conditions.

The Contractor shall at all times comply with all applicable FTA regulations, policies, procedures and directives, including without limitation those listed directly or by reference in the Master Agreement between Agency and FTA, as they may be amended or promulgated from time to time during the term of this Contract. Contractor's failure to so comply shall constitute a material breach of this Contract.

### **FR 3. Federal Energy Conservation Requirements**

The Contractor agrees to comply with mandatory standards and policies relating to energy efficiency that are contained in the state energy conservation plan issued in compliance with the Energy Policy and Conservation Act.

## FR 4. Civil Rights Requirements

The following requirements apply to the underlying Contract:

1. **Nondiscrimination:** In accordance with Title VI of the Civil Rights Act, as amended, 42 USC § 2000d, section 303 of the Age Discrimination Act of 1975, as amended, 42 USC § 6102, section 202 of the Americans with Disabilities Act of 1990, 42 USC § 12132, and federal transit law at 49 USC § 5332, the Contractor agrees that it will not discriminate against any employee or applicant for employment because of race, color, creed, national origin, sex, age, or disability. In addition, the Contractor agrees to comply with applicable federal implementing regulations and other implementing requirements FTA may issue.
2. **Equal Employment Opportunity:** The following equal employment opportunity requirements apply to the underlying Contract:
  - (a) **Race, Color, Creed, National Origin, Sex:** In accordance with Title VII of the Civil Rights Act, as amended, 42 USC § 2000e, and federal transit laws at 49 USC § 5332, the Contractor agrees to comply with all applicable equal employment opportunity requirements of U.S. Department of Labor (U.S. DOL) regulations, “Office of Federal Contract Compliance Programs, Equal Employment Opportunity, Department of Labor,” 41 CFR Parts 60 *et seq.*, (which implement Executive Order No. 11246, “Equal Employment Opportunity,” as amended by Executive Order No. 11375, “Amending Executive Order 11246 Relating to Equal Employment Opportunity,” 42 USC § 2000e note), and with any applicable federal statutes, executive orders, regulations, and federal policies that may in the future affect construction activities undertaken in the course of the Project. The Contractor agrees to take affirmative action to ensure that applicants are employed, and that employees are treated during employment, without regard to their race, color, creed, national origin, sex, or age. Such action shall include, but not be limited to, the following: employment, upgrading, demotion or transfer, recruitment or recruitment advertising, layoff or termination; rates of pay or other forms of compensation; and selection for training, including apprenticeship. In addition, the Contractor agrees to comply with any implementing requirements FTA may issue.
  - (b) **Age:** In accordance with section 4 of the Age Discrimination in Employment Act of 1967, as amended, 29 USC §§ 623 and federal transit law at 49 USC § 5332, the Contractor agrees to refrain from discrimination against present and prospective employees for reason of age. In addition, the Contractor agrees to comply with any implementing requirements FTA may issue.
  - (c) **Disabilities:** In accordance with section 102 of the Americans with Disabilities Act, as amended, 42 USC § 12112, the Contractor agrees that it will comply with the requirements of U.S. Equal Employment Opportunity Commission, “Regulations to Implement the Equal Employment Provisions of the Americans with Disabilities Act,” 29 CFR Part 1630, pertaining to employment of persons with disabilities. In addition, the Contractor agrees to comply with any implementing requirements FTA may issue.
3. The Contractor also agrees to include these requirements in each subcontract financed in whole or in part with federal assistance provided by FTA, modified only if necessary to identify the affected parties.

## FR 5. No Government Obligation to Third Parties

1. The Agency and Contractor acknowledge and agree that, notwithstanding any concurrence by the federal government in or approval of the Solicitation or award of the underlying Contract, absent the express written consent by the federal government, the federal government is not a party to this Contract and shall not be subject to any obligations or liabilities to the Agency, Contractor, or any

other party (whether or not a party to that Contract) pertaining to any matter resulting from the underlying Contract.

2. The Contractor agrees to include the above clause in each subcontract financed in whole or in part with federal assistance provided by FTA. It is further agreed that the clause shall not be modified, except to identify the Subcontractor who will be subject to its provisions.

## **FR 6. Program Fraud and False or Fraudulent Statements or Related Acts**

1. The Contractor acknowledges that the provisions of the Program Fraud Civil Remedies Act of 1986, as amended, 31 USC §§ 3801 *et seq.* and U.S. DOT regulations, “Program Fraud Civil Remedies,” 49 CFR Part 31, apply to its actions pertaining to this Project. Upon execution of the underlying Contract, the Contractor certifies or affirms the truthfulness and accuracy of any statement it has made, it makes, it may make, or it causes to be made, pertaining to the underlying Contract or the FTA-assisted project for which this Contract Work is being performed. In addition to other penalties that may be applicable, the Contractor further acknowledges that if it makes, or causes to be made, a false, fictitious or fraudulent claim, statement, submission or certification, the federal government reserves the right to impose the penalties of the Program Fraud Civil Remedies Act of 1986 on the Contractor to the extent the federal government deems appropriate.
2. The Contractor also acknowledges that if it makes, or causes to be made, a false, fictitious, or fraudulent claim, statement, submission, or certification to the federal government under a Contract connected with a project that is financed in whole or in part with Federal assistance originally awarded by FTA under the authority of 49 USC § 5307, the government reserves the right to impose the penalties of 18 USC § 1001 and 49 USC § 5307(n)(1) on the Contractor, to the extent the federal government deems appropriate.
3. The Contractor agrees to include the above two clauses in each subcontract financed in whole or in part with federal assistance provided by FTA. It is further agreed that the clauses shall not be modified, except to identify the Subcontractor who will be subject to the provisions.

## **FR 7. Suspension and Debarment**

This Contract is a covered transaction for purposes of 49 CFR Part 29. As such, the Contractor is required to verify that none of the Contractor, its principals, as defined at 49 CFR 29.995, or affiliates, as defined at 49 CFR 29.905, are excluded or disqualified as defined at 49 CFR 29.940 and 29.945.

The Contractor is required to comply with 49 CFR 29, Subpart C, and must include the requirement to comply with 49 CFR 29, Subpart C, in any lower-tier covered transaction it enters into.

By signing and submitting its bid or Proposal, the Bidder or Proposer certifies as follows:

The certification in this clause is a material representation of fact relied upon by CARTA. If it is later determined that the Bidder or Proposer knowingly rendered an erroneous certification, in addition to remedies available to CARTA, the federal government may pursue available remedies, including but not limited to suspension and/or debarment. The Bidder or Proposer agrees to comply with the requirements of 49 CFR 29, Subpart C, while this Proposal is valid and throughout the period of any Contract that may arise from this Proposal. The Bidder or Proposer further agrees to include a provision requiring such compliance in its lower tier covered transactions.

## **FR 8. Disadvantaged Business Enterprise (DBE)**

This Contract is subject to the requirements of Title 49, Code of Federal Regulations, Part 26, Participation by Disadvantaged Business Enterprises in Department of Transportation Financial Assistance Programs.

The Contractor shall maintain compliance with “DBE Approval Certification” throughout the period of Contract performance.

The Contractor shall not discriminate on the basis of race, color, national origin or sex in the performance of this Contract. The Contractor shall carry out applicable requirements of 49 CFR Part 26 in the award and administration of this DOT-assisted Contract. Failure by the Contractor to carry out these requirements is a material breach of this Contract, which may result in the termination of this Contract or such other remedy as CARTA deems appropriate. Each subcontract the Contractor signs with a Subcontractor must include the assurance in this paragraph (see 49 CFR 26.13(b)).

## **FR 9. Clean Water Requirements**

1. The Contractor agrees to comply with all applicable standards, orders or regulations issued pursuant to the Federal Water Pollution Control Act, as amended, 33 USC 1251 *et seq.* The Contractor agrees to report each violation to the Agency and understands and agrees that the Agency will, in turn, report each violation as required to ensure notification to FTA and the appropriate EPA Regional Office.
2. The Contractor also agrees to include these requirements in each subcontract exceeding \$100,000 financed in whole or in part with federal assistance provided by FTA.

## **FR 10. Clean Air Requirements**

1. The Contractor agrees to comply with all applicable standards, orders or regulations issued pursuant to the Clean Air Act, as amended, 42 USC §§ 7401 *et seq.* The Contractor agrees to report each violation to the Agency and understands and agrees that the Agency will, in turn, report each violation as required to ensure notification to FTA and the appropriate EPA Regional Office.
2. The Contractor also agrees to include these requirements in each subcontract exceeding \$100,000 financed in whole or in part with federal assistance provided by FTA.

## **FR 11. Compliance with Federal Lobbying Policy**

Contractors who apply or bid for an award of \$100,000 or more shall file the certification required by 49 CFR Part 20, “New Restrictions on Lobbying.” Each tier certifies to the tier above that it will not and has not used federal appropriated funds to pay any person or organization for influencing or attempting to influence an officer or employee of any Agency, a member of Congress, an officer or employee of Congress, or an employee of a member of Congress in connection with obtaining any federal Contract, grant or any other award covered by 31 USC 1352. Each tier shall also disclose the name of any registrant under the Lobbying Disclosure Act of 1995 who has made lobbying contacts on its behalf with non-federal funds with respect to that federal Contract, grant or award covered by 31 USC 1352. Such disclosures are forwarded from tier to tier up to the recipient.

## **FR 12. Buy America**

The Contractor agrees to comply with 49 USC 5323(j) and 49 CFR Part 661, which provide that federal funds may not be obligated unless steel, iron and manufactured products used in FTA-funded projects are produced in the United States, unless a waiver has been granted by FTA or the product is subject to a general waiver. General waivers are listed in 49 CFR 661.7. A general public interest waiver from the Buy America requirements applies to microprocessors, computers, microcomputers, software or other such devices, which are used solely for the purpose of processing or storing data. This general waiver does not extend to a product or device that merely contains a microprocessor or microcomputer and is not used solely for the purpose of processing or storing data.

Separate requirements for rolling stock are set out at 49 USC 5323(j)(2)(C) and 49 CFR 661.11. Rolling stock must be assembled in the United States and have a 60 percent domestic content.

A Bidder or Proposer must submit to the Agency the appropriate Buy America Certification with all offers on FTA-funded contracts, except those subject to a general waiver. Proposals that are not accompanied by a properly completed Buy America certification are subject to the provisions of 49 CFR 661.13 and may be rejected as nonresponsive.

### FR 13. Testing of New Bus Models

The Contractor agrees to comply with 49 USCA 5323(c) and FTA's implementing regulation at 49 CFR Part 665 and shall perform the following:

1. A manufacturer of a new bus model or a bus produced with a major change in components or configuration shall provide a copy of the final test report to the recipient at a point in the procurement process specified by the recipient, which will be prior to the recipient's final acceptance of the first vehicle.
2. A manufacturer who releases a report under Paragraph 1 above shall provide notice to the operator of the testing facility that the report is available to the public.
3. If the manufacturer represents that the vehicle was previously tested, the vehicle being sold should have the identical configuration and major components as the vehicle in the test report, which must be provided to the recipient prior to recipient's final acceptance of the first vehicle. If the configuration or components are not identical, the manufacturer shall provide a description of the change and the manufacturer's basis for concluding that it is not a major change requiring additional testing.
4. If the manufacturer represents that the vehicle is "grandfathered" (has been used in mass transit service in the United States before October 1, 1988, and is currently being produced without a major change in configuration or components), the manufacturer shall provide the name and address of the recipient of such a vehicle and the details of that vehicle's configuration and major components.

### FR 14. Pre-Award and Post-Delivery Audits

The Contractor agrees to comply with 49 USC § 5323(1) and FTA's implementing regulation at 49 CFR Part 663 and to submit the following certifications:

1. **Buy America requirements:** The Contractor shall complete and submit a declaration certifying either compliance or noncompliance with Buy America. If the recommended Bidder/Proposer certifies compliance with Buy America, it shall submit documentation that lists (1) component and subcomponent parts of the rolling stock to be purchased identified by manufacturer of the parts, their country of origin and costs; and (2) the location of the final assembly point for the rolling stock, including a description of the activities that will take place at the final assembly point and the cost of final assembly.
2. **Solicitation specification requirements:** The Contractor shall submit evidence that it will be capable of meeting the bid specifications.
3. **Federal Motor Vehicle Safety Standards (FMVSS):** The Contractor shall submit (1) manufacturer's FMVSS self-certification, Federal Motor Vehicle Safety Standards, that the vehicle complies with relevant FMVSS or (2) manufacturer's certified statement that the contracted buses will not be subject to FMVSS regulations.

### FR 15. Cargo Preference

The Contractor agrees to the following:

- To use privately owned U.S.-flag commercial vessels to ship at least fifty (50) percent of the gross tonnage (computed separately for dry bulk carriers, dry cargo liners and tankers) involved, whenever



- shipping any equipment, material or commodities pursuant to the underlying Contract to the extent such vessels are available at fair and reasonable rates for U.S.-flag commercial vessels;
- To furnish within twenty (20) working days following the date of loading for shipments originating within the United States or within thirty (30) working days following the date of leading for shipments originating outside the United States, a legible copy of a rated, “on-board” commercial ocean bill of lading in English for each shipment of cargo described in the preceding paragraph to the Division of National Cargo, Office of Market Development, Maritime Administration, Washington, DC 20590 and to the FTA recipient (through the Contractor in the case of a Subcontractor’s bill-of-lading.)
  - To include these requirements in all subcontracts issued pursuant to this Contract when the subcontract may involve the transport of equipment, material or commodities by ocean vessel.

## FR 16. Fly America

The Contractor agrees to comply with 49 USC 40118 (the “Fly America” Act) in accordance with the General Services Administration’s regulations at 41 CFR Part 301-10, which provide that recipients and sub recipients of federal funds and their Contractors are required to use U.S. flag air carriers for U.S. government-financed international air travel and transportation of their personal effects or property, to the extent such service is available, unless travel by foreign air carrier is a matter of necessity, as defined by the Fly America Act. The Contractor shall submit, if a foreign air carrier was used, an appropriate certification or memorandum adequately explaining why service by a U.S.-flag air carrier was not available or why it was necessary to use a foreign air carrier and shall, in any event, provide a certificate of compliance with the Fly America requirements. The Contractor agrees to include the requirements of this section in all subcontracts that may involve international air transportation.

## FR 17. Contract Work Hours and Safety Standards Act

1. **Overtime requirements:** No Contractor or Subcontractor contracting for any part of the Contract Work that may require or involve the employment of laborers or mechanics shall require or permit any such laborer or mechanic in any workweek in which he or she is employed on such Work to work in excess of 40 hours in such workweek unless such laborer or mechanic receives compensation at a rate not less than one and one-half times the basic rate of pay for all hours worked in excess of 40 hours in such workweek.
2. **Violation; liability for unpaid wages; liquidated damages:** In the event of any violation of the clause set forth in paragraph 1 of this section, the Contractor and any Subcontractor responsible therefore shall be liable for the unpaid wages. In addition, such Contractor and Subcontractor shall be liable to the United States for liquidated damages. Such liquidated damages shall be computed with respect to each individual laborer or mechanic, including watchmen and guards, employed in violation of the clause set forth in paragraph 1 of this section, in the sum of \$10 for each calendar day on which such individual was required or permitted to work in excess of the standard workweek of 40 hours without payment of the overtime wages required by the clause set forth in paragraph 1 of this section.
3. **Withholding for unpaid wages and liquidated damages:** CARTA shall upon its own action or upon written request of an authorized representative of the Department of Labor withhold or cause to be withheld, from any monies payable on account of work performed by the Contractor or Subcontractor under any such contract or any other federal contract with the same Prime Contractor, or any other federally assisted contract subject to the Contract Work Hours and Safety Standards Act, which is held by the same Prime Contractor, such sums as may be determined to be necessary to satisfy any liabilities of such Contractor or Subcontractor for unpaid wages and liquidated damages as provided in the clause set forth in paragraph 2 of this section.
4. **Subcontracts:** The Contractor or Subcontractor shall insert in any subcontracts the clauses set forth in paragraphs 1 through 4 of this section and also a clause requiring the Subcontractors to include

these clauses in any lower-tier subcontracts. The Prime Contractor shall be responsible for compliance by any Subcontractor or lower-tier Subcontractor with the clauses set forth in paragraphs 1 through 4 of this section.

## SECTION 6: TECHNICAL SPECIFICATIONS

### GENERAL

#### TS 1. Scope

Technical specifications define requirements for the furnishing of Heavy-Duty Forty Foot (40') Battery-Electric Low Floor Transit Buses, which, by the selection of specifically identified alternative configurations, may be used for both suburban express service and general service on urban arterial streets. Buses have a minimum expected life of twelve (12) years or 500,000 miles, whichever comes first, and are intended for the widest possible spectrum of passengers, including children, adults, the elderly and people with disabilities.

#### TS 2. Definitions

- (1) **dB(A)**: Decibels with reference to 0.0002 microbar as measured on the "A" scale.
- (2) **Audible Discrete Frequency**: An audible discrete frequency is determined to exist if the sound power level in any 1/3-octave band exceeds the average of the sound power levels of the two adjacent 1/3-octave bands by 4 decibels (dB) or more.
- (3) **Battery Compartment**: Low-voltage energy storage, i.e. 12/24 VDC batteries.
- (4) **Battery Management System (BMS)**: Monitors energy, as well as temperature, cell or module voltages, and total pack voltage. The BMS adjusts the control strategy algorithms to maintain the batteries at uniform state of charge and optimal temperatures.
- (5) **Cells**: Individual components (i.e., battery or capacitor cells). (3) **Standee Line**. A line marked across the bus aisle to designate the forward area that passengers may not occupy when the bus is moving.
- (6) **Free Floor Space**: Floor area available to standees, excluding the area under seats, area occupied by feet of seated passengers, the vestibule area forward of the standee line, and any floor space indicated by manufacturer as non-standee areas such as, the floor space "swept" by passenger doors during operation. Floor area of 1.5 square feet shall be allocated for the feet of each seated passenger that protrudes into the standee area.
- (7) **Curb Weight**: Weight of vehicle, including maximum fuel, oil and coolant, and all equipment required for operation and required by this Specification, but without passengers or operator.
- (8) **Seated Load**: One hundred fifty pounds for every designed passenger seating position and for the operator.
- (9) **Gross Load**: One hundred fifty pounds for every designed passenger seating position, for the operator, and for each 1.5 square feet of free floor space.
- (10) **SLW (Seated Load Weight)**: Curb weight plus seated load.
- (11) **GVW (Gross Vehicle Weight)**: Curb weight plus gross load.

- (12) **VWR (Gross Vehicle Weight Rated)**: The maximum total weight as determined by the vehicle manufacturer, at which the vehicle can be safely and reliably operated for its intended purpose.
- (13) **GAWR (Gross Axle Weight Rated)**: The maximum total weight as determined by the axle manufacturer, at which the axle can be safely and reliably operated for its intended purpose.
- (14) **Heavy Heavy-Duty Gas Engine (HHDG)**: Heavy heavy-duty gas engines have sleeved cylinder liners, are designed for multiple rebuilds, and a rated horsepower that generally exceeds 250.
- (15) **Operator's Eye Range**: The 95th-percentile ellipse defined in SAE Recommended Practice J941, except that the height of the ellipse shall be determined from the seat at its reference height.
- (16) **Fireproof**: Materials that will not burn or melt at temperatures less than 2,000° F.
- (17) **Fire Resistant**: Materials that have a flame spread index less than 150 as measured in a radiant panel flame test per ASTM-E 162-90.
- (18) **Human Dimensions**: The human dimensions used in the Technical Specifications are defined in Humanscale 1/2/3, N. Diffrient, A. R. Tilley, J. C. Bardagjy, MIT Press.
- (19) **HIC (Head Injury Criteria)**: The following equation presents the definition of head injury

$$\left[ \frac{1}{t_1 - t_2} \int_{t_2}^{t_1} (a) dt \right]^{2.5} (t_2 - t_1)$$

- (20) **Alternative**: An alternative specification condition to the baseline configuration bus. The customer may define alternatives to the baseline configuration to satisfy local operating requirements. Alternatives for the baseline configuration will be clearly identified
- (21) **Class of Failures**: Classes of failures are described below.
- a. **Class 1: Physical Safety**. A failure that could lead directly to passenger or operator injury or represents a severe crash situation.
  - b. **Class 2: Road Call**. A failure resulting in an en route interruption of revenue service. Service is discontinued until the bus is replaced or repaired at the point of failure.
  - c. **Class 3: Bus Change**. A failure that requires removal of the bus from service during its assignments. The bus is operable to a rendezvous point with a replacement bus.
  - d. **Class 4: Bad Order**. A failure that does not require removal of the bus from service during its assignments but does degrade bus operation. The failure shall be reported by operating personnel.

- (22) **Maintenance Personnel Skill Levels:** Defined below are maintenance personnel skill levels used in the technical specification.
- a. 5M: Specialist Mechanic or Class A Mechanic Leader
  - b. 4M: Journeyman or Class A Mechanic
  - c. 3M: Service Mechanic or Class B Servicer
  - d. 2M: Mechanic Helper or Bus Servicer
  - e. 1M: Cleaner, Fueler, Oiler, Hostler, or Shifter
- (23) **Standards:** Standards are the latest revisions unless otherwise stated.
- (24) **Wheelchair:** A mobility aid belonging to any class of three or four-wheeled devices, usable indoors, designed for and used by individuals with mobility impairments, whether operated manually or powered. A “common wheelchair” is such a device that does not exceed 30 inches in width and 48 inches in length measured two inches above the ground, and does not weigh more than 600 pounds when occupied.
- (25) **Structure:** The structure shall be defined as the basic body, including floor deck material and installation, load bearing external panels, structural components, axle mounting provisions and suspension beams and attachment points.
- (26) **Low Floor Bus:** A bus which, between at least the front (entrance) and rear (exit) doors, has a floor sufficiently low and level so as to remove the need for steps in the aisle between the doors and in the vicinity of these doors.
- (27) **F/2.8:** Defines the opening size of a camera iris. The lower the f-stop, the better the image quality available at low light conditions.
- (28) **Discrete Signals:** A signal which can take only pre-defined values, usually of a binary 0 or 1 nature where 0 is battery ground potential and 1 is a defined battery positive potential.
- (29) **Analog Signals:** A continuously-variable signal that is solely dependent upon magnitude to express information content. Note: Analog signals are used to represent the state of variable devices such as rheostats, potentiometers, temperature probes, etc.
- (30) **Serial Data Signals:** Serial data signals are a current loop based representation of ASCII or Alphanumeric data used for transferring information between devices by transmitting a sequence of individual bits in a prearranged order of significance. Note: An example is the communication that takes place between two or more electronic components with the ability to process and store information.
- (31) **Physical Layer:** The first layer of the seven-layer International Standards Organization (ISO) Open Systems Interconnect (OSI) reference model. This provides the mechanical, electrical, functional and procedural characteristics required to gain access to the transmission medium (e.g., cable) and is responsible for transporting binary information between computerized systems.

- (32) **Ambient Temperature**: The temperature of the surrounding air. For testing purposes, ambient temperature must be between + 16° C (+50° F) and +38° C (+100° F).
- (33) **Code**: A legal requirement.
- (34) **DC to DC Converter**: A module that converts a source of direct current from one voltage level to another.
- (35) **Drive System**: Consists of Drive Motor, Drive Motor Controller (Inverter), gearbox or transmission and drive shaft along with related mounting hardware.
- (36) **Destroyed**: Physically made permanently unusable.
- (37) **Energy Density**: The relationship between the weight of an energy storage device and its power output in units of watt-hours per kilogram (Wh/kg).
- (38) **Energy Storage System (ESS)**: A component or system of components that stores energy and for which its supply of energy is rechargeable by the on-vehicle system (engine/regenerative braking/ generator) or an off-vehicle energy source.
- (39) **Fusible Material**: A metal, alloy, or other material capable of being melted by heat.
- (40) **Hybrid System Controller (HSC)**:Regulates energy flow throughout hybrid system components in order to provide motive performance and accessory loads, as applicable, while maintaining critical system parameters (voltages, currents, temperatures, etc.) within specified operating ranges.
- (41) **Labeled**: Equipment or materials to which has been attached a label, symbol, or other identifying mark of an organization, that is acceptable to the authority having jurisdiction and concerned with product evaluation, that maintains periodic inspection of production labeled equipment or materials, and by whose labeling the manufacturer indicates compliance with appropriate standards or performance in a specified manner.
- (42) **Leakage**: Release of contents through a defect or crack. See "Rupture."
- (43) **Metallic Hose**: A hose whose strength depends primarily on the strength of its metallic parts; it can have metallic liners or covers, or both.
- (44) **Motor (Electric)**: A device that converts electrical energy into mechanical energy.
- (45) **Motor (Traction)**: An electric motor used to power the driving wheels of the bus.
- (46) **Power**: Work or energy divided by time.
- (47) **Power Density**: Power divided by mass, volume or area.
- (48) **Propulsion System**: System that provides propulsion for the vehicle proportional to operator commands. Includes, as applicable, engine, transmission, traction motors, the hybrid drive system, (HDS), energy storage system (ESS), and system controllers including all wiring and converter/inverter.

- (49) **Real-Time Clock (RTC)**: Computer clock that keeps track of the current time.
- (50) **Regenerative Braking**: Deceleration of the bus by switching motors to act as generators, which return vehicle kinetic energy to the energy storage system.
- (51) **Standard**: A firm guideline from a consensus group.
- (52) **State of Charge (SOC)**: Quantity of electric energy remaining in the battery relative to the maximum rated amp-hour (Ah) capacity of the battery expressed in a percentage. This is a dynamic measurement used for the energy storage system. A full SOC indicates that the energy storage system cannot accept further charging from the engine-driven generator or the regenerative braking system.
- (53) **Stress Loops**: The "pig-tails" commonly used to absorb flexing in piping.
- (54) **Structure**: The structure shall be defined as the basic body, including floor deck material and installation, load bearing external panels, structural components, axle mounting provisions and suspension beams and attachment points.
- (55) **Usable Battery Capacity**: Usable Battery capacity is measured in kWhr and would be the energy available for normal operations. Usable Battery Capacity would be the usable energy from the ESD as managed through the BMS, Assumed to be less than the gross capacity. It is calculated based on a useful range of something above 0% SOC and something less than 100% SOC, i.e., as an example, if the range was between 10% and 90% SOC, then the usable battery capacity would be 80% of gross battery capacity
- (56) **Warrantable End of Life (WEOL)**: WEOL is measure of battery degradation determined as the point at which the batteries can no longer provide the energy or power required to meet the design operating profile. It is expressed as a percentage of remaining battery capacity as compared to gross capacity at the beginning of useful life. For purposes of this specification, WEOL shall be a measure of the useful and intended life of the energy storage device. This measure shall be a percentage of remaining useful capacity based on degradation from the beginning capacity, i.e. kWhr and is used in the overall calculation of mileage range. WEOL shall be used as a condition for battery replacement and to potentially initiate warranty claims.
- (57) **Wheelchair**: A mobility aid belonging to any class of three- or four-wheeled devices, usable indoors, designed for and used by individuals with mobility impairments, whether operated manually or powered. A "common wheelchair" is such a device that does not exceed 30 in. in width and 48 in. in length measured in. above the ground, and does not weigh more than 600 lbs when occupied.

### TS 3. Referenced Publications

The documents or portions thereof referenced within this specification shall be considered part of the requirements of the specification. The edition indicated for each referenced document is the current edition, as of the date of the APTA issuance of this specification.

## **TS 4. Legal Requirements**

The Contractor will comply with all applicable federal, state and local regulations. These will include but not be limited to ADA, as well as state and local accessibility, safety and security requirements. Local regulations are defined as those below the state level.

Buses will meet all applicable FMVSS regulations and will accommodate all applicable FMCSR regulations in effect at the location of the Agency and the date of manufacture.

In the event of any conflict between the requirements of these specifications and any applicable legal requirement, the legal requirement will prevail. Technical requirements that exceed the legal requirements are not considered to conflict.

## **TS 5. Overall Requirements**

The contractor shall ensure that the application and installation of major bus sub-components and systems are compliant with all such sub-component vendors' requirements and recommendations. Components used in the vehicle shall be of heavy-duty design and proven in transit service.

Components used in the vehicle shall be of heavy-duty design and proven in transit service. Whenever a specific trade or product name is used within this specification, the following statement applies "...or approved equal with the same standards of quality, design and performance." All requests for approved equals must be submitted to the Agency for review.

### **TS 5.1 Weight**

It will be a design goal to construct each bus as light in weight as possible without degradation of safety, appearance, comfort, traction or performance. The curb weight of the vehicle shall be equal to or less than 30,000 lbs.

Buses at a capacity load will not exceed the tire factor limits, brake test criteria or structural design criteria.

### **TS 5.2 Capacity**

The vehicle shall be designed to carry the Gross Vehicle Weight as defined in TS 2, which shall not exceed the bus GVWR. The vehicle shall not exceed the individual gross axle weight rating (GAWR) at curb weight plus gross load.

### **TS 5.3 Service Life**

The minimum useful design life of the bus in transit service will be at least twelve (12) years or 500,000 miles. It will be capable of operating at least 40,000 miles per year, including the 12th year.

### **TS 5.4 Maintenance and Inspection**

Scheduled maintenance tasks will be related and in accordance with the manufacturer's recommended preventative maintenance schedule (along with routine daily service performed during the fueling operations).

Diagnostic test ports, as required, will be provided for commonly checked functions on the bus, such as air intake, exhaust, hydraulic, pneumatic, charge-air and motor cooling systems.

The coach manufacturer will give prime consideration to the routine problems of maintaining the vehicle. All coach components and systems, both mechanical and electrical, which will require periodic physical work or inspection processes are installed so that a minimum of time is consumed in gaining access to the critical repair areas. It will not be necessary to disassemble portions of the coach structure and/or equipment such as



seats and flooring under seats in order to gain access to these areas. Each coach will be designed to facilitate the disassembly, reassembly, servicing or maintenance, using tools and equipment that are normally available as standard commercial items.

Requirements for the use of unique specialized tools will be minimized. The body and structure of the coach will be designed for ease of maintenance and repair. Individual panels or sections of a monocoque composite body or other equipment that may be damaged in normal service shall be easily repairable or replaceable. Ease of repair will be related to the vulnerability of the item to damage in service.

Contractor will provide a list of all special tools and pricing required for maintaining this equipment. Said list will be submitted as a supplement to the Pricing Schedule.

### **TS 5.5 Interchangeability**

Unless otherwise agreed, all units and components procured under this Contract, whether provided by Suppliers or manufactured by the Contractor, are duplicates in design, manufacture and installation to ensure interchangeability among buses in each order group in this procurement. This interchangeability extends to the individual components as well as to their locations in the buses. These components include, but are not limited to, passenger window hardware, interior trim, lamps, lamp lenses and seat assemblies. Components with non-identical functions will not be, or appear to be, interchangeable.

Any one component or unit used in the construction of these buses will be an exact duplicate in design, manufacture and assembly for each bus in each order group in this Contract. Contractor will identify and secure approval for any changes in components or unit construction provided within a Contract.

In the event that the Contractor is unable to comply with the interchangeability requirement, the Contractor will notify the Agency and obtain the Agency's prior written approval, including any changes in pricing.

Agency will review proposed product changes on a case-by-case basis and has the right to require extended warranties to ensure that product changes perform at least as well as the originally supplied products.

### **TS 5.6 Training**

The Contractor will have at least one qualified instructor who will be available at the Agency's property at a time and for a duration mutually agreed to by both parties. Instructor(s) will conduct schools and advise the personnel of the Agency on the proper operation and maintenance of the equipment. The Contractor also will provide visual and other teaching aids (such as manuals, slide presentations and literature) for use by the Agency's own training staff, which become the property of the Agency.

### **TS 5.7 Technical/Service Representatives**

The Contractor will, at its own expense, have one or more competent technical service representatives available on request to assist the Agency in the solution of engineering or design problems within the scope of the specifications that may arise during the warranty period. This does not relieve the Contractor of responsibilities under the provisions of "Section 7: Warranty Requirements."

### **TS 5.8 Operating Environment**

The bus achieves normal operation in ambient temperature ranges of 10 °F to 115 °F, at relative humidity between 5 percent and 100 percent, and at altitudes up to 3000 ft above sea level. Degradation of performance due to atmospheric conditions is minimized at temperatures below 10 °F, above 115 °F or at altitudes above 3000 ft. Speed, gradeability and acceleration performance requirements are met at, or corrected to, 77 °F, 29.31 in. Hg, dry air per SAEJ1995.

## **TS 5.9 Noise**

### **TS 5.9.1 Interior Noise**

The combination of inner and outer panels and any material used between them provides sufficient sound insulation so that a sound source with a level of 80 dBA measured at the outside skin of the bus has a sound level of 65 dBA or less at any point inside the bus. These conditions prevail with all openings, including doors and windows, closed and with the motor and accessories switched off.

The bus-generated noise level experienced by a passenger at any seat location in the bus does not exceed 80 dBA. The driver area does not experience a noise level of more than 75 dBA.

### **TS 5.9.2 Exterior Noise**

Airborne noise generated by the bus and measured from either side does not exceed 70 dBA under full power acceleration when operated at 0 to 35 mph at curb weight. The maximum noise level generated by the bus pulling away from a stop at full power does not exceed 80 dBA. The bus-generated noise at curb idle does not exceed 70 dBA. If the noise contained an audible discrete frequency, a penalty of 5 dBA was added to the sound level measured. The Contractor will comply with the exterior noise requirements defined in local laws and ordinances identified by the Agency and SAEJ366.

## **TS 5.10 Fire Safety**

The bus shall be designed and manufactured in accordance with all applicable fire safety and smoke emission regulations. These provisions shall include the use of fire-retardant/low-smoke materials, fire detection systems, bulkheads and facilitation of passenger evacuation..

## **TS 5.11 Fire Suppression**

The bus shall be designed and manufactured in accordance with all applicable fire safety and smoke emission regulations. These provisions include the use of fire-retardant/low-smoke materials, fire detection systems, bulkheads and facilitation of passenger evacuation. Fire extinguisher to be provided with each vehicle.

## **TS 5.12 Respect for the Environment**

In the design and manufacture of the bus, the Contractor has made every effort to reduce the amount of potentially hazardous waste. In accordance with Section 6002 of the Resource Conservation and Recovery Act, the Contractor uses, whenever possible and allowed by the specifications, recycled materials in the manufacture of the bus.

# DIMENSIONS

## TS 6. Physical Size

With exceptions such as exterior mirrors, marker and signal lights, bumpers, fender skirts, washers, wipers, ad frames, cameras, object detection systems, bicycle racks, feelers and rubrails, the bus has the following overall dimensions as shown in **Figure 1** at static conditions and design height.

**FIGURE 1**  
Transit Bus Exterior Dimensions

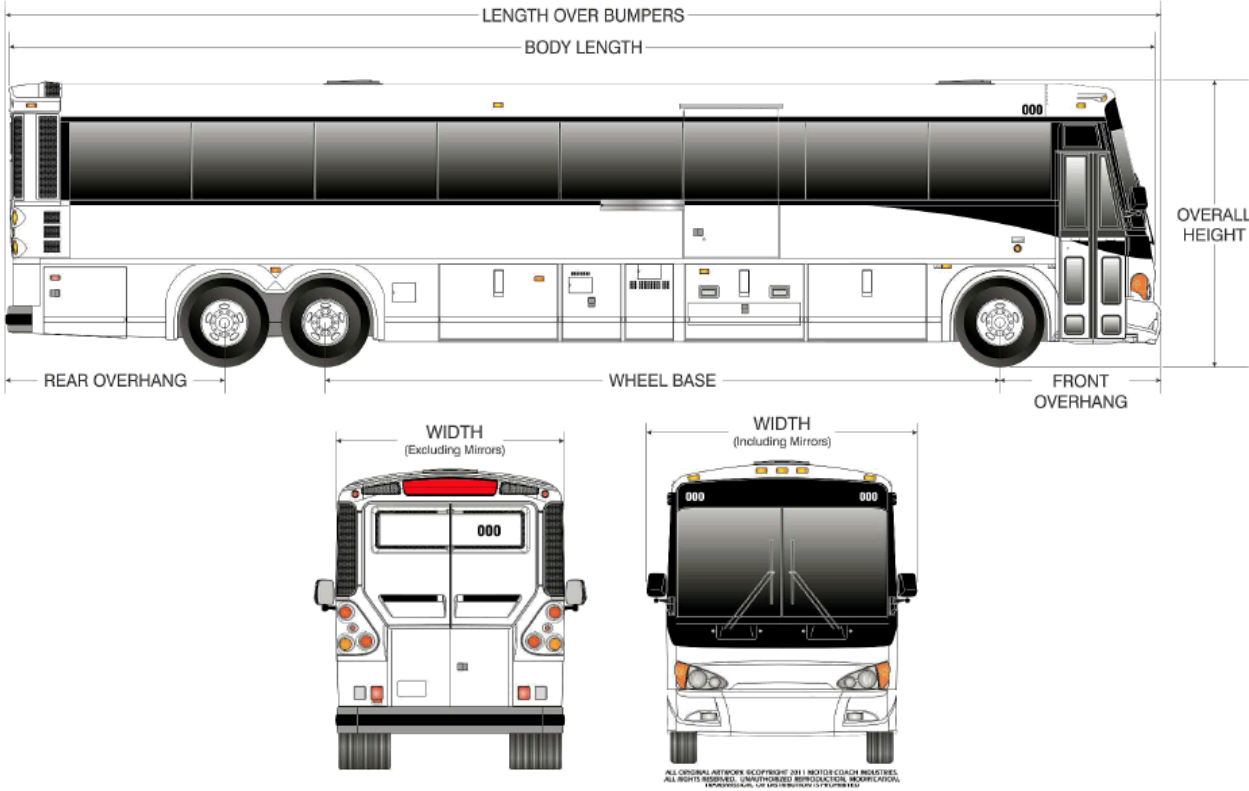

### TS 6.1 Bus Length

For ease of use, the following tolerances will be allowable for each given bus length. Bus length is determined as the measurement from bumper to bumper.

- **40ft bus:** 40ft to 44ft, 11 in.

### TS 6.2 Bus Width

Body width shall be 102 in. (+0, -1 in.).

### TS 6.3 Bus Height

#### Maximum Overall Height

Maximum overall height shall be 135 in., including all rigid, roof-mounted items such as A/C, exhaust, fuel system and cover, etc.

### TS 6.4 Step Height

Height of the floor above the street shall be no more than 16.5 inches measured at the entry door and 17 inches at the rear doorway.

### TS 6.5 Underbody Clearance

The bus maintains the minimum clearance dimensions as defined and shown in Figure 2 of SAE Standard J689, regardless of load up to the gross vehicle weight rating. This is accomplished with height sensors at all four corners of the vehicle.

### TS 6.6 Ramp Clearances

The approach angle is the angle measured between a line tangent to the front tire static loaded radius arc and the initial point of structural interference forward of the front tire to the ground.

The departure angle is the angle measured between a line tangent to the rear tire static loaded radius arc and the initial point of structural interference rearward of the rear tire to the ground.

The breakover angle is the angle measured between two lines tangent to the front and rear tire static loaded radius and intersecting at a point on the underside of the vehicle that defines the largest ramp over which the vehicle can roll.

**TABLE 2**

Angle	35- to 45-ft Bus
Approach	8.6 deg (min.)
Breakover (normal ride height)	7.0 deg (min.)
Departure	8.6 deg (min.)

### TS 6.7 Ground Clearance

Ground Clearance: Ground clearance shall be no less than 9 inches (8 inches at jacking pad), except within the axle zone and wheel area.

Axle Clearance: Axle zone clearance, which is the projected area between tires and wheels on the same axial centerline, shall be no less than 5 1/2 inches.

Wheel Area Clearance: Wheel area clearance, shall be no less than 8 inches for parts fixed to the bus body and 6 inches for parts that move vertically with the axles.

### TS 6.8 Floor Height

Height of the step above the street shall be no more than 16.5 inches measured at the centerline of the front doorway and 17 inches at the centerline of the rear doorway. The floor may be inclined along the longitudinal axis of the bus, and the incline shall be less than 3 1/2 degrees off the horizontal except locally at the doors where a maximum 5 degrees slope toward the door is allowed.

### TS 6.9 Interior Headroom

Headroom above the aisle and at the centerline of the aisle seats shall be no less than 78 inches forward of the rear raised area tapering to no less than 74 inches forward of the rear settee. At the centerline of the window

seats, headroom shall be no lower than 65 inches. Headroom at the back of the rear bench seat may be reduced to a minimum of 56 inches, but it shall increase to the ceiling height at the front of the seat cushion. In any area of the bus directly over the head of a seated passenger and positioned where a passenger entering or leaving the seat is prone to strike his/her head, padding shall be provided on the overhead paneling.

### **TS 6.10 Aisle Width**

The minimum clear aisle width between pairs of transverse seats with all attached hardware shall be at least 22 in.

The aisle width between the front wheelhouses shall be at least 35.5 in., and the entire area between the front wheelhouses shall be available for passengers and mobility aid devices.

## **VEHICLE PERFORMANCE**

### **TS 7. Power Requirements**

The propulsion system shall be sized to provide sufficient power to enable the bus to meet the defined acceleration, top speed, and gradability requirements, and operate all propulsion-driven accessories using actual road test results and computerized vehicle performance data.

#### **TS 7.1 Top Speed**

The bus shall be capable of achieving a top speed of 65 mph on a straight, level road at GVWR with all accessories operating, and shall be governed at a top speed of 65 mph. The bus shall be capable of safely maintaining the vehicle speed according to the recommendations by the tire manufacturer.

#### **TS 7.2 Gradability**

Gradeability requirements shall be met on grades with a dry commercial asphalt or concrete pavement at GVWR with all accessories operating. The propulsion system shall be required to enable the bus to achieve a speed of 40 mph on a 2.5% ascending grade and 15mph on a 10% ascending grade.

#### **TS 7.3 Acceleration**

The acceleration shall meet the requirements below and shall be sufficiently gradual and smooth to prevent throwing standing passengers off-balance. Acceleration measurement shall commence when the accelerator is depressed.

**TABLE 3**  
Maximum Start Acceleration Times on a Level Surface<sup>1</sup>

<b>Speed (mph)</b>	<b>Maximum time (seconds)</b>
10	5
20	10
30	20
40	31

## **TS 7.4 Operating Range**

The operating range of the coach shall be designed to meet the operating profile as stated in the “Design Operating Profile” section.

### **TS 7.4.1 Electric**

The operating range of the coach with full state of charge shall be at least 150 miles at the vehicle’s GVWR with auxiliary loads. The Contractor shall include a calculation of its operating range by identifying the coach’s Usable Battery Capacity divided by its projected fuel efficiency at full GVWR with auxiliary loads.

## **TS 8. Fuel Economy (Design Operating Profile)**

Test results from the Altoona fuel economy tests or other applicable test procedures shall be provided to the Agency. Results shall include vehicle configuration and test environment information. Fuel economy data shall be provided for each design operating profile. The design operating profile is assumed to be defined by the Altoona fuel duty cycle.

Fuel economy tests shall be run on these three duty cycles: CBD, Arterial, and Commuter.

## **POWERPLANT**

### **TS 9. Propulsion System**

#### **Propulsion System Description**

The bus shall be powered by a battery electric propulsion system. The propulsion system shall utilize an appropriately sized permanent magnet (PM) traction motor. The propulsion system shall comply with applicable local, state, and/or federal emissions and useful life requirements, as a zero emission bus. The propulsion system shall be rated for the GVWR or greater of the bus.

#### **Propulsion Control System**

The drive motor shall be equipped with an electronically controlled management system, compatible with 12-volt power distribution. The motor control system shall be capable of transmitting and receiving electronic inputs and data from other drivetrain components, and broadcasting that data to other vehicle systems. Communication between electronic drivetrain components and other vehicle systems shall be made using the communications networks.

The battery electric drive system shall have onboard diagnostic capabilities able to monitor vital motor functions, store and time stamp parameter conditions in memory, and communicate faults and vital conditions to service personnel. Diagnostic reader device connector ports, suitably protected against dirt and moisture, shall be provided in the operator’s area. The onboard diagnostic system shall inform the operator via visual and/or audible alarms when out of parameter conditions exist for vital engine functions. The on-board diagnostic system shall have capabilities for storing hard and soft codes and processing data and provide detailed information/reports on various aspects of fleet usage. The information shall be retrievable via cabling or wireless transmission to a laptop.

The motor drive shall protect the drive system against progressive damage. The system shall monitor conditions critical for safe operation and automatically de-rate power and/or speed and initiate motor shutdown as needed. The on-board diagnostic system shall trigger a visual and audible alarm to the operator when the motor control unit detects a malfunction and the engine protection system is activated.

Automatic shutdown shall only occur when parameters established for the functions below are exceeded:

- Over Temp
- Inverter Fault
- Over Voltage
- Broken Wire
- Loss of Electrical Communications
- Communications Safety
- No redundant bus manufacturer and/or component manufacturer "detection and shutdown" circuits. By default, the component manufacturer's software shall be used to record fault codes.

A control shall be available to the operator to allow a 30-second override, which, when depressed, will allow the operator to delay the drive system shutdown but not the activation and alarm system.

### **Propulsion System Service**

The PM motor shall be designed to operate for not less than 300,000 miles without major failure or significant deterioration. Components of the control system shall be designed to operate for not less than 150,000 miles without replacement or major service.

The propulsion system shall be arranged so that accessibility for all routine maintenance is assured. No special tools, other than dollies and hoists, shall be required to remove the propulsion system or any subsystems. However, the Agency shall recognize that properly rated test equipment and safe electrical work practices are essential when servicing high voltage components. Contractor shall provide all specialty tools and diagnostic equipment required for maintaining the Propulsion System in accordance with Special Tools List.

### **Energy Storage System**

An overview of the design and performance of the Energy Storage System (ESS) shall be provided to the Agency. The ESS shall be capable of operating in the Agency transit environment. The ESS shall be designed, sized, and selected to ensure that the vehicle performance specifications, compatibility with charging, and other related requirements are met or exceeded, bearing in mind cost benefit and reliability variables as they relate to the characteristics of the different battery types. The power source for the vehicle shall be derived from established battery technology that has a field-proven track record of safe, reliable, and durable operation in similar applications.

The primary charging of the energy storage system shall be accomplished by conductive charging as needed to meet the required duty cycle. The charging shall be provided from a stationary charging station via a mechanical or manual conductive interface, i.e., plug. The energy storage system shall also make use of regenerative braking. The Energy Storage System shall comply with UN/DOT 38.3 requirements for lithium batteries or similar standards for non-lithium batteries.

The Contractor shall deliver the buses with an installed, fully-charged, functioning ESS. The ESS shall be fully formed, installed and tested in accordance with the battery manufacturer's recommended practices. The ESS design, including containers, module bracing systems, thermal-management systems, battery management systems, watering/venting systems, interconnections, fusing, and traction-controller and charger interfaces should be completely described in the proposal. The proposal shall include a detailed analysis of expected battery performance in the Design Operating Profile. The proposal should also include a comprehensive statement of the warranty terms

relating to the battery, including explanation of all disclaimers within the warranty. The charge cycle and cycle life should be stated in the proposal and a life cycle cost analysis of the proposed battery system in the specified application should be provided.

The battery system shall be capable of withstanding the high current and voltage profiles necessary to accomplish daily recharge events without reducing the life of the battery.

### **Energy Storage System Safety**

The ESS battery packs shall be located outside the passenger compartment and in a position outside of a direct side or rear impact zone. Additionally, the ESS batteries shall be load distributed within the bus to equalize weight between the wheels on the same axles and to achieve appropriate weight distribution between axles so as not to adversely affect handling of the bus.

The bus body shall be purpose-design and constructed to ensure passengers and the operator will not be exposed to electrical current either in normal operation or in the event of a vehicle accident. Analysis and test data shall be provided to the Agency. The ESS shall be designed and constructed to prevent gassing or fumes from the ESS from entering the interior of the bus, i.e., a vent path to the exterior.

Proposals shall include complete descriptions of all safety standards followed in the design and manufacture of the battery system, safety testing procedures used to validate the safety of battery operation in this application, and documented results of safety testing to confirm that standards have been met.

### **Battery Management System**

As a minimum, the battery management system (BMS) must perform the following functions:

- A. The BMS system must be capable of monitoring the voltage level of cells within each battery pack. The BMS must be able to read and store individual battery or block voltages at a frequency of 1 data point per block every 15 seconds. The system must also monitor battery pack temperatures using no fewer than 2 thermocouples placed in and around each battery pack sampled at the same 4 samples per minute frequency.
- B. The BMS system must be capable of communicating when a battery fault (as defined by the battery manufacturer) has occurred and must be able to identify and communicate the faulty battery in order to perform maintenance.
- C. The BMS system must be capable of engaging prudent safety interlocks when an unsafe battery condition has been detected.
- D. The BMS system must be able to monitor the battery state-of charge and update a gauge viewed by the operator at least once every 15 seconds.
- E. The BMS system must be able to communicate all data to the bus level information system for storage and communication.

### **Battery Thermal Management**

Battery thermal management must be powered from an onboard source at all times. Thermal management must be continuously monitored at all times with appropriate safety interlocks installed to react to adverse conditions.



Battery temperatures must never exceed the manufacturer's recommended range during operation in the design operating profile and specified ambient conditions. Battery cooling must be sufficient to prevent the temperature from exceeding the battery manufacturer's recommended maximum temperature when the ambient temperature is above 105 degrees F for a period of 16 hours.

### **ESS Control System**

The ESS control system shall be a hierarchical control with the energy storage module (ESM) acting as the interface and lead controller to the rest of the battery system. This module shall communicate on the main vehicle CAN bus to interface with the cooling, powertrain, charge and other systems. This module shall also communicate on the separate battery CAN bus with all of the individual packs. The main controller interface shall exchange information about battery input and output capability as well as cooling needs and diagnostic information.

The ESS battery pack controllers shall gather the current information as well as pack voltage, cell voltage, and temperature information. The master controller shall use this information to compute system limits, determine health, and ultimately apply system-wide boundaries on use. All of the contactors in the system shall have feedback to allow the system to know if there is a potential for high voltage to be present when it shouldn't be. The temperature measurements in the ESS battery pack must be redundant in nature. The ESS battery packs must also include sensors to detect moisture and monitor the current distribution between the pack in order to confirm it is within an acceptable range.

The ESS control system shall provide system discharge limits to ensure that the lowest cell never goes below its minimum and the system charge limit to ensure that the highest cell never goes above its maximum. The system shall also comprehend current imbalance between the packs, temperatures throughout all of the packs, moisture, and isolation detection.

## **TS 10. Cooling Systems**

The cooling systems shall be of sufficient size to maintain all motor, transmissions, controller and battery system fluids at safe, continuous operating temperatures during the most severe operations possible and in accordance with the manufacturers' cooling system requirements. The cooling system fan/fans control should sense the temperatures of the operating fluids and the intake air and if either is above safe operating conditions the cooling fan should be engaged. The fan control system shall be designed with a fail-safe mode of "fan on." The cooling system in new condition shall have an ambient capacity of at least 115° F with water as coolant and sea level operation.

### **TS 10.1 Propulsion Cooling**

The transmission shall be equipped with a standalone oil to air cooler mounted next to the transmission.

The drive motor shall be cooled by a liquid-based cooling system that does not permit boiling or coolant loss during operation. The cooling fan shall be temperature controlled, preventing the drive motor from exceeding manufacturer's recommended operating temperatures. The temperature-controlled fan shall idle or not be driven when the coolant temperature falls below the minimum level recommended by the engine manufacture. Air vent valves shall be fitted at high points in the cooling system unless it can be demonstrated that the system is self-purging.

A low-level coolant sensor shall be provided and shall be accessible by an exterior access door at ground level. The sensor shall display both at the filler location as well as on the dash. The water filler shall be no more than 60 inches above the ground and both shall be accessible through the same access door.

The radiator, shall be of durable corrosion-resistant construction with integral tanks, unless the EMP Mini-Hybrid System is installed. Plastic tanks are not permitted. All radiators shall be designed so a 2M mechanic can gain access to a substantial portion for the purpose of cleaning the radiators in five minutes or less.

Radiators with a fin density greater than 12 fins per inch, and louvered/slit designs, are more susceptible to clogging and deteriorating cooling performance over time and shall not be used.

All hose clamps shall be constant tension type clamps.

The radiators shall be designed to withstand thermal fatigue and vibration associated with the installed configuration.

### **TS 10.1.1 Radiator Screen**

The bus shall be equipped with 2 radiators: one for power electronics and propulsion system; and the other for battery cooling. Both radiators shall be designed to withstand thermal fatigue and vibration associated with the installed configuration. The radiator cores shall be easily cleaned with standard pressure-washing equipment.

### **TS 10.1.2 Coolant**

The bus shall be equipped with coolant filtration. The filter shall be sized properly with a spin-on element that does not contain supplemental coolant additives.

### **TS 10.1.3 Drive Design**

The bus shall be equipped with an electric fan drive bus cooling system. A screen guard must installed on electric motor fans per SAE J1308.

### **TS 10.1.4 Mounting**

The radiators must be roof mounted.

## **TS 10.2 Charge Air Cooling**

N/A

## **TS 10.3 Transmission Cooling**

The transmission shall be cooled by a dedicated heat exchanger sized to maintain operating fluid within the transmission manufacturer's recommended parameters of flow, pressure and temperature. The transmission cooling system must be separate from the traction motor cooling system. The transmission cooling system shall be a standalone system designed to circulate oil through a small radiator next to the transmission.

## **TS 11. Transmission**

If applicable, the transmission shall be a multiple-speed, automatically shifted transmission with electronic controls. A torque converter and retarder are not needed. Gross input power, gross input torque and rated input speed shall be compatible with the traction motor. The transmission must be designed to operate for no less than 300,000 miles on the design operating profile without replacement or major service. The transmission must be easily removable without disturbing the traction motor and accessible for service.

The electronic controls must be capable of transmitting and receiving electronic inputs and data from other drivetrain components and of broadcasting that data to other vehicle systems. Communication between

electronic drivetrain components and other vehicle systems shall be made using the communications networks. Electronic controls must be compatible with 24 V power distribution, provide consistent shift quality, and compensate for changing conditions, such as variations in vehicle weight and engine power. At a minimum, drivetrain components consisting of the motor, transmission and anti-lock braking systems must be powered to ensure data communication among components exists when the vehicle ignition is switched to the “on” position.

The electronically controlled powertrain and vehicle controller must have on-board diagnostic capabilities, be able to monitor functions, store and time-stamp out-of-parameter conditions in memory, and communicate faults and vital conditions to service personnel. The transmission must contain built-in protection software to guard against severe damage. The on-board diagnostic system shall be required to trigger a visual alarm to the driver when the electronic control unit detects a malfunction.

The transmission must be an automatically shifted unit with manual transmission architecture, i.e. gears, shafts and shift collars but with no clutches, or torque converter, therefore there is not a need to monitor the fluid on an ongoing basis. The fluid will remain at a constant level between specified fluid change intervals.

## **TS 12. Regenerative Braking**

The bus shall have a regenerative braking system to aid in the reduction of wear on the brakes and to help extend the range of the vehicle through energy recapture. The vehicle will employ regenerative braking as the accelerator pedal is completely released. Regenerative braking shall be additionally increased as the brake pedal is applied which shall also increase service brake application.

## **TS 13. Engine Brake**

N/A

## **TS 14. Mounting**

All powerplant mounting is mechanically isolated to minimize transfer of vibration to the body structure and provide a minimum clearance of 0.75 in. Mounts control the movement of the powerplant so as not to cause strain in piping and wiring connections to the powerplant.

### **TS 14.1 Service**

The propulsion system shall be arranged so that accessibility for all routine maintenance is assured. No special tools, other than dollies and hoists, shall be required to remove the drive motor. Two 3M mechanics shall be able to remove and replace the drive motor and gearbox in 8hours or less.

Radiator fillers shall be arranged so as to ensure simple, efficient filling while tethering the cap and ensuring the filler is closed when filling is completed. All fluid fill locations shall be properly labeled to help ensure correct fluid is added and all fillers shall be easily accessible with standard funnels, pour spouts, and automatic dispensing equipment. All lubricant sumps shall be fitted with magnetic-type, drain plugs.

## **TS 15. Hydraulic Systems**

Hydraulic system service tasks shall be minimized and scheduled no more frequently than those of other major coach systems. All elements of the hydraulic system must be easily accessible for service or unit replacement. Critical points in the hydraulic system should be fitted with service ports so that portable diagnostic equipment may be connected or sensors for an off-board diagnostic system permanently attached to monitor system operation when applicable.

The hydraulic system shall operate within the allowable temperature range as specified by the lubricant manufacturer.

The hydraulic system shall be of a modular design which can be removed with no more than four bolts.

### **TS 15.1 Fluid Lines**

All lines and piping shall be supported to prevent chafing damage, fatigue failures, and tension strain. All hydraulic line routings shall be supported by click-bond supported HellermannTyton fittings and clamps designed for this application, or approved equal. Lines passing through a panel, frame, or bulkhead shall be protected by grommets (or similar device) that fit snugly to both the line and the perimeter of the hole that the line passes through to prevent chafing and/or wear.

All flexible lines shall be as short as practicable, no greater than 6 feet in length, unless demonstrated inappropriate for a given application, and shall be routed or shielded to deter spraying or draining onto any component operable above the auto-ignition temperature of the line's contents in case of line failure. Flexible hoses and fluid lines shall not touch one another, or any part of the bus.

Flexible lines shall be compatible with the fluids they are intended to carry, at all expected temperatures and pressures and shall have standard SAE, JIC or ORS brass or steel, swivel, end fittings. Flexible hoses over 1 inch in diameter shall be in conformance with SAE J100R5. Flexible hoses and fluid lines shall not abrade one another, or any part of the bus.

### **TS 15.2 Fittings and Clamps**

Compression fittings shall be standardized as much as practicable to prevent the intermixing of components. Compression fitting components from more than one manufacturer shall not be mixed even if the components are known to be interchangeable.

### **TS 15.3 Charge Air Piping**

N/A

### **TS 16. Radiator**

Radiator piping shall be stainless steel, brass tubing, or powder coated steel; and, if practicable, hoses shall be eliminated. EPDM coolant hoses for heavy vehicle applications SAEJ20R3 specs, and silicone in limited areas as required.

All hoses shall be as short as practicable. All hoses shall be secured with constant tension spring clamps made from high tensile spring steel (51CrV4) and treated for 1000 hour ASTM B-117 corrosion resistance. 1. The clamps shall maintain a constant tension at all times, expanding and contracting with the hose in response to temperature changes and aging of the hose material.

### **TS 17. Oil and Hydraulic Lines**

Oil and hydraulic lines shall be compatible with the substances they carry. The lines must be designed and intended for use in the environment where they are installed.

Hydraulic lines of the same size and with the same fittings as those on other piping systems of the bus, but not interchangeable, are tagged or marked for use on the hydraulic system only.

## **TS 18. Fuel**

N/A

## **TS 19. Emissions and Exhaust**

N/A

## **STRUCTURE**

### **TS 20. General**

#### **TS 20.1 Design**

The structure of the bus shall be designed to withstand the transit service conditions typical of an urban duty cycle throughout its service life. The vehicle structural frame shall be a fully monocoque composite body designed to operate with minimal maintenance throughout the 12-year design operating profile. The design operating profile specified by the Agency shall be considered for this purpose.

### **TS 21. Altoona Testing**

Prior to acceptance of first bus, the vehicle must have completed any FTA-required Altoona testing. Any items that required repeated repairs or replacement will undergo corrective action with supporting test and analysis. A report clearly describing and explaining the failures and corrective actions taken to ensure that any and all such failures will not occur will be submitted to the Agency. If available, the Altoona Test Report shall be provided to the Agency with the Proposal submittal. If not available, then the report shall be provided prior to first acceptance of bus.

#### **TS 21.1 Structural Validation**

The structure of the bus shall have undergone appropriate structural testing and/or analysis. At a minimum, appropriate structural testing and analysis shall include Altoona testing and/or Finite Element Analysis (FEA).

### **TS 22. Distortion**

The bus, loaded to GVWR and under static conditions, shall not exhibit deflection or deformation that impairs the operation of the steering mechanism, doors, windows, passenger escape mechanisms or service doors. Static conditions include the vehicle at rest with any one wheel or dual set of wheels on a 6 in. curb or in a 6 in. deep hole.

### **TS 23. Resonance and Vibration**

All structure, body and panel-bending mode frequencies, including vertical, lateral and torsional modes, are sufficiently removed from all primary excitation frequencies to minimize audible, visible or sensible resonant vibrations during normal service.

#### **TS 23.1 Motor Compartment Bulkheads**

The passenger and motor compartment shall be separated by fire-resistant bulkheads. This bulkhead shall preclude or retard propagation of an motor compartment fire into the passenger compartment and is in accordance with the Recommended Fire Safety Practices defined in FTA Docket 90A, dated October 20, 1993. Only necessary openings are allowed in the bulkhead, and these must be fire-resistant. Climate controlled air shall not pass through the motor compartment. Wiring passing through the bulkhead must use connectors or other means to prevent or retard fire propagation through the bulkhead. No motor access panels shall be required in the bulkhead.

## **TS 23.2 Crashworthiness**

The bus body and roof structure shall withstand a static load equal to 150 percent of the curb weight evenly distributed on the roof with no more than a 6 in. reduction in any interior dimension. Windows shall remain in place and shall not open under such a load. These requirements must be met without the roof-mounted equipment installed.

The bus shall withstand a 25 mph impact by a 4000-pound automobile at any side, excluding doorways, along either side of the bus with no more than 3 in. of permanent structural deformation at seated passenger hip height. This impact shall not result in sharp edges or protrusions in the bus interior.

The bus body below 35 in. from ground level shall withstand a static load of 2000 lbs applied perpendicular to the bus by a pad no larger than 5 sq in. This load shall not result in deformation that prevents repair of the body to the original appearance of the bus.

The crashworthiness requirements may be met by either test or Finite Element Analysis (FEA).

## **TS 24. Corrosion**

The bus flooring, sides, roof, understructure, axle suspension components shall resist corrosion or deterioration from atmospheric conditions and road salts for a period of 12 years or 500,000 miles whichever comes first. It shall maintain structural integrity and nearly maintain original appearance throughout its service life, provided that it is maintained by the customer in accordance with the procedures specified in the Contractor's service manual. With the exception of periodically inspecting the visible coatings applied to prevent corrosion and reapplying these coatings in limited spots, the Contractor shall not require the complete reapplication of corrosion compounds over the life of the bus.

All materials that are not inherently corrosion resistant shall be protected with corrosion-resistant coatings. All joints and connections of dissimilar metals shall be corrosion-resistant and shall be protected from galvanic corrosion. Representative samples of all materials and connections shall withstand a 2-week (336-hour) salt spray test in accordance with ASTM Procedure B-117 with no structural detrimental effects to normally visible surfaces, and no weight loss of over 1 percent.

In the event that the bus body is made from corrosion resistant composite materials, it shall not need any undercoating spray. All exposed metal surfaces under the bus shall be both E-coated and powder coated.

## **TS 25. Towing**

Each towing device shall withstand, without permanent deformation, tension loads up to 1.2 times the curb weight of the bus within 20 degrees of the longitudinal axis of the bus. If applicable, the rear towing device(s) shall not provide a toehold for unauthorized riders. The method of attaching the towing device shall not require the removal, or disconnection, of front suspension or steering components. Removal of the bike rack is permitted for attachment of towing devices.

If applicable, the rear towing device(s) shall permit lifting and towing of the bus for a short distance, such as in cases of an emergency, to allow access to provisions for front towing of the bus. The method of attaching the tow bar or adapter shall require the specific approval of the Agency. Each towing device shall accommodate a crane hook with a 1-inch throat.

## **TS 26. Jacking**

It shall be possible to safely jack up the bus, at curb weight, with a common 10-ton floor jack with or without special adapter, when a tire or dual set is completely flat and the bus is on a level, hard surface, without

crawling under any portion of the bus. Jacking from a single point permits raising the bus sufficiently high to remove and reinstall a wheel and tire assembly. Jacking pads located on the axle or suspension near the wheels shall permit easy and safe jacking with the flat tire or dual set on a 6 in. high run-up block not wider than a single tire. The bus shall withstand such jacking at any one or any combination of wheel locations without permanent deformation or damage.

Jacking pads shall be painted safety yellow and decals are applied to identify locations.

## **TS 27. Hoisting**

The bus axles or jacking plates shall accommodate the lifting pads of a two-post hoist system. Jacking plates, if used as hoisting pads, are designed to prevent the bus from falling off the hoist. Other pads or the bus structure supports the bus on jack stands independent of the hoist.

The vehicle shall be capable of being lifting by the wheels.

## **TS 28. Floor**

### **TS 28.1 Design**

The floor design shall consist of two levels (bi-level construction). Aft of the rear door extending to the rear settee riser, the floor height may be raised to a height approximately 21 in. above the lower level. An increased slope shall be allowed on the upper level not to exceed  $3\frac{1}{2}^\circ$  off the horizontal.

### **TS 28.2 Strength**

The floor deck may be integral with the basic structure or mounted on the structure securely to prevent chafing or horizontal movement and designed to last the life of the bus. Sheet metal screws shall not be used to retain the floor, and all floor fasteners must be serviceable from one side only. Any adhesives, bolts or screws used to secure the floor to the structure shall last and remain effective throughout the life of the coach. All floor fasteners shall be secured and protected from corrosion for the service life of the bus.

The floor deck shall be reinforced as needed to support passenger loads. At GVWR, the floor shall have an elastic deflection of no more than 0.60 in. from the normal plane. The floor must withstand the application of 2.5 times gross load weight without permanent detrimental deformation. The floor, with coverings applied, shall withstand a static load of at least 150 lbs applied through the flat end of a  $\frac{1}{2}$  in. diameter rod, with  $\frac{1}{32}$  in. radius, without permanent visible deformation.

### **TS 28.3 Construction**

The floor shall consist of the subfloor and the floor covering that will last the life of the bus. The floor as assembled, including the sealer, attachments and covering, shall be waterproof, non-hygroscopic and resistant to mold growth. The subfloor shall be resistant to the effects of moisture, including decay (dry rot). It shall be impervious to wood-destroying insects such as termites.

## **TS 29. Platforms**

### **TS 29.1 Driver's Area**

The covering of platform surfaces and risers, except where otherwise indicated, shall be the same material as specified for floor covering. Trim is provided along top edges of platforms unless integral nosing is provided.

## TS 29.2 Driver's Platform

The operator's platform shall be of a height that, in a seated position, the driver can see an object located at an elevation of 42" above the road surface, 24" from the leading edge of the bumper. Notwithstanding this requirement, the platform height shall not position the operator such that the operator's vertical upward view is less than 15 degrees. A warning decal or sign shall be provided to alert operator to the change in floor level. The following schematic diagram illustrates a means by which the platform height can be determined, using the Critical Line of Sight. **Figure 2** illustrates the means by which this requirement was determined.

**FIGURE 2**  
Determining Platform Height

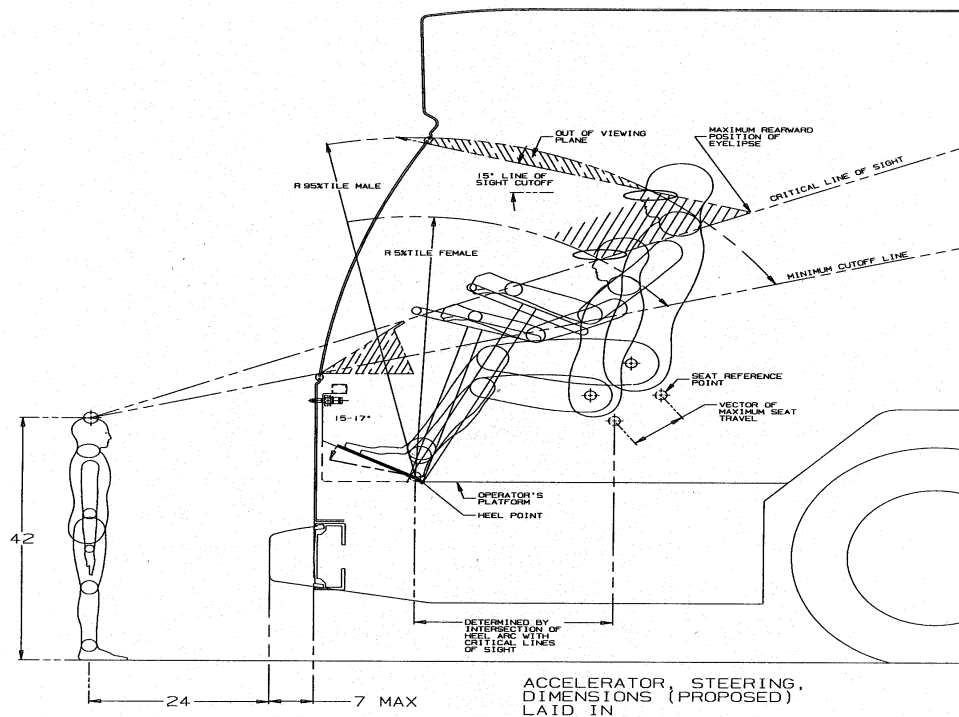

## TS 29.3 Farebox

Farebox placement should minimize impact to passenger access and minimize interference with the driver's line of sight.

### Driver Interface Required; Platform Needed to Bring Height to Driver Access

If the driver's platform is higher than 12 in., then the farebox is to be mounted on a platform of suitable height to provide accessibility for the driver without compromising passengers' access.

## TS 29.4 Rear Step Area to Rear Area

If the vehicle is of a bi-level floor design, a rear step area shall be provided along the center aisle of the bus to facilitate passenger traffic between the upper and lower floor levels. This step area shall be cut into the rear platform and shall be approximately the aisle width, a minimum 12 in. deep and approximately half the height of the upper level relative to the lower level. The horizontal surface of this platform shall be covered with skid-resistant material with a visually contrasting nosing and shall be sloped slightly for drainage. A warning decal or sign shall be provided at the immediate platform area to alert passengers to the change in floor level.



## **TS 30. Wheel Housing**

### **TS 30.1 Design and Construction**

Sufficient clearance and air circulation shall be provided around the tires, wheels and brakes to preclude overheating when the bus is operating on the design operating profile. Wheel housings shall be constructed of corrosion-resistant and fire-resistant material.

Design and construction of front wheel housings shall allow for the installation of a radio or electronic equipment storage compartment on the interior top surface, or its use as a luggage rack.

The finish of the front wheel housings shall be scratch-resistant and complement interior finishes of the bus to minimize the visual impact of the wheel housing. If fiberglass wheel housings are provided, then they shall be color-impregnated to match interior finishes.

Wheel housings, as installed and trimmed, withstand impacts of a 2in. steel ball with at least 200 ft-lbs of energy without penetration.

## **CHASSIS**

### **TS 31. Suspension**

#### **TS 31.1 General Requirements**

The front and rear suspensions shall be pneumatic type. The basic suspension system shall last the service life of the bus without major overhaul or replacement. Normal replacement items, such as one suspension bushing, shock absorbers, or air spring shall be replaceable by a 3M mechanic in 30 minutes or less. Adjustment points shall be minimized and shall not be subject to a loss of adjustment in service. Necessary adjustments shall be easily accomplished without removing or disconnecting the components.

#### **TS 31.2 Alignment**

All axles shall be properly aligned so the vehicle tracks accurately within the size and geometry of the vehicle.

#### **TS 31.3 Springs and Shock Absorbers**

##### **TS 31.3.1 Suspension Travel**

The suspension system shall permit a minimum wheel travel of 2.75 in. jounce-upward travel of a wheel when the bus hits a bump (higher than street surface), and 2.75 in. rebound-downward travel when the bus comes off a bump and the wheels fall relative to the body. Elastomeric bumpers shall be provided at the limit of jounce travel. Rebound travel may be limited by elastomeric bumpers or hydraulically within the shock absorbers. Suspension shall incorporate appropriate devices for automatic height control so that regardless of load the bus height relative to the centerline of the wheels does not change more than ½ in. at any point from the height required. The safe operation of a bus will not be impacted by ride height up to 1 in. from design normal ride height.

##### **TS 31.3.2 Damping**

Vertical damping of the suspension system shall be accomplished by hydraulic shock absorbers mounted to the suspension arms or axles and attached to an appropriate location on the chassis. Damping shall be sufficient to control coach motion to three cycles or less after hitting road perturbations. The shock absorber bushing shall be made of elastomeric material that will last the life of the shock absorber. The damper shall incorporate a secondary hydraulic rebound stop.

### TS 31.3.3 Lubrication

All elements of steering, suspension and drive systems requiring scheduled lubrication will be provided with grease fittings conforming to SAE Standard J534. These fittings shall be located for ease of inspection and shall be accessible with a standard grease gun from a pit or with the bus on a hoist. Each element requiring lubrication has its own grease fitting with a relief path. The lubricant specified shall be standard for all elements on the bus serviced by standard fittings and is required no less than every 6000 miles.

### TS 31.3.4 Kneeling

A kneeling system shall lower the entrance(s) of the bus a minimum of 2.5 inches during loading or unloading operations regardless of load up to GVWR, measured at the longitudinal centerline of the entrance door(s), by the driver. The kneeling control shall use a three position, spring loaded to center switch, and provide the following functions:

- Downward control will lower the bus.
- Release of switch at any time shall completely stop the lowering motion and hold height of the bus at that position.
- Upward direction of the switch will allow the system to go to floor height without the driver having to hold the switch up.

Brake and Throttle interlock shall prevent movement when the bus is kneeled. The kneeling control shall be disabled when the bus is in motion. The bus shall kneel at a maximum rate of 1.25 inches per second at essentially a constant rate. After kneeling, the bus shall rise within 5 seconds to a height permitting the bus to resume service and shall rise to the correct operating height within 7 seconds regardless of load up to GVWR. During the lowering and raising operation, the maximum acceleration shall not exceed 0.2g and the jerk shall not exceed 0.3g/sec.

An indicator visible to the driver shall be illuminated until the bus is raised to a height adequate for safe street travel. An audible warning alarm will sound simultaneously with the operation of the kneeler to alert passengers and bystanders. A warning light mounted near the curbside of the front door, minimum 2" diameter, amber lens shall be provided that will blink when the kneel feature is activated. Kneeling shall not be operational while the wheelchair ramp is deployed or in operation.

## TS 32. Wheels and Tires

### TS 32.1 Wheels

All wheels shall be interchangeable. Wheels are compatible with tires in size and load-carrying capacity. Front wheels and tires are balanced as an assembly per SAE J1986.

Wheels shall be hub-piloted, brushed aluminum, and shall resist rim flange wear. Wheels shall have a low maintenance special finish, Alcoa 22.5 buffed aluminum or equivalent.

Spare tire and wheel shall be provided with each vehicle.

### TS 32.2 Tires

Tires shall be suitable for the conditions of transit service and sustained operation at the maximum speed capability of the bus. Load on any tire at GVWR shall not exceed the tire supplier's rating. **Each vehicle shall include 1 spare tire and wheel.**

- *Current vehicle standards: Alcoa 22.5x9" Clean Buff Aluminum Wheels PN: 896517*

- **Tires:** *Michelin 315/80R22.5(or approved equal)*
- *Vehicles shall be equipped with a Veeder Root Hubometer*
- *Vehicles shall be equipped with torque indicators, Green (Current Wheel Check WLCH-B)*

Bus manufacturer shall designate tire size in accordance with FMVSS requirements and manufacturer's recommendations. If the buses must be equipped with low profile standard transit tires, with a specific load range, as appropriate for the bus design, the Contractor must advise with the technical proposal.

### **TS 33. Steering**

An electrically driven power steering hydraulic pump shall be provided. Hydraulic assisted steering shall be provided to reduce steering effort. The steering gear must be an integral type with the number and length of flexible lines minimized or eliminated.

#### **TS 33.1 Steering and Tag Axles**

The front axle shall be of an independent suspension design, non-driving with a load rating sufficient for the bus loaded to GVWR and shall be equipped with grease type front wheel bearings and seals.

All friction points on the front axle shall be equipped with replaceable bushings or inserts and lubrication fittings easily accessible from a pit or hoist.

#### **TS 33.2 Steering Wheel**

##### **TS 33.2.1 Turning Effort**

Steering effort is measured with the bus at GVWR, stopped with the brakes released on clean, dry, level, commercial asphalt pavement and the tires inflated to recommended pressure.

Under these conditions, the torque required to turn the steering wheel 10° shall be no less than 5 ft-lbs and no more than 10 ft-lbs. Steering torque may increase to 70 ft-lbs when the wheels are approaching the steering stops, as the relief valve activates.

Power steering failure shall not result in loss of steering control. With the bus in operation, the steering effort will not exceed 55 lbs at the steering wheel rim, and perceived free play in the steering system will not materially increase as a result of power assist failure. Gearing shall require no more than seven turns of the steering wheel lock-to-lock.

Caster angle shall be selected to provide a tendency for the return of the front wheels to the straight position with minimal assistance from the driver.

##### **TS 33.2.2 Steering Wheel, General**

The steering wheel diameter shall be approximately 18 to 20 in.; the rim diameter is 7/8 to 1 1/4 in. and shaped for firm grip with comfort for long periods of time.

Steering wheel spokes and wheel thickness ensures visibility of the dashboard so that vital instrumentation is clearly visible at center neutral position (within the range of a 95th-percentile male, as described in SAE 1050a, Sections 4.2.2 and 4.2.3). Placement of steering column is as far forward as possible, and in line with the instrument cluster.

**TS 33.2.3 Steering Column Tilt**

The steering wheel shall have a rearward tilt adjustment range of no less than 30 degrees as measured from the horizontal and upright position.

**TS 33.2.4 Steering Wheel Telescopic Adjustment**

The steering wheel shall have full telescoping capability and have a minimum telescopic range of 2 in. and a minimum low-end adjustment of 29 in., measured from the top of the steering wheel rim in the horizontal position to the cab floor at the heel point.

**TABLE 4**  
Steering Wheel Height<sup>1</sup> Relative to Angle of Slope

At Minimum Telescopic Height Adjustment (29 in.)		At Maximum Telescopic Height Adjustment (5 in.)	
Angle of Slope	– Height	– Angle of Slope	Height
0 deg.	29 in.	0 deg.	34 in.
15 deg.	26.2 in.	15 deg.	31.2 in.
25 deg.	24.6 in.	25 deg.	29.6 in.
35 deg.	22.5 in.	35 deg.	27.5 in.

– 1. Measured from bottom portion closest to driver.

**TS 34. Drive Axle**

The bus shall be driven by a heavy-duty axle with a load rating sufficient for the bus loaded to GVWR. The drive axle shall have a design life to operate for not less than 300,000 miles on the design operating profile without replacement or major repairs. The lubricant drain plug shall be magnetic type. The oil level in the planetary gears shall be easily checked through the plug or sight gauge. The axle and driveshaft components shall be rated for both propulsion and retardation modes with respect to duty cycle.

The drive shaft is guarded to prevent hitting any critical systems, including brake lines, coach floor or the ground, in the event of a tube or universal joint failure.

**TS 34.1 Non-Drive Axle**

N/A

**TS 35. Tag Axles**

N/A

**TS 36. Turning Radius**

**TABLE 5**  
Maximum Turning Radius

Bus Length (approximate)	Maximum Turning Radius (see Figure 3)	Agency Requirement
35 ft	39 ft (TR0)	
40 ft	44 ft (TR0)	

**FIGURE 3**  
Turning Radius

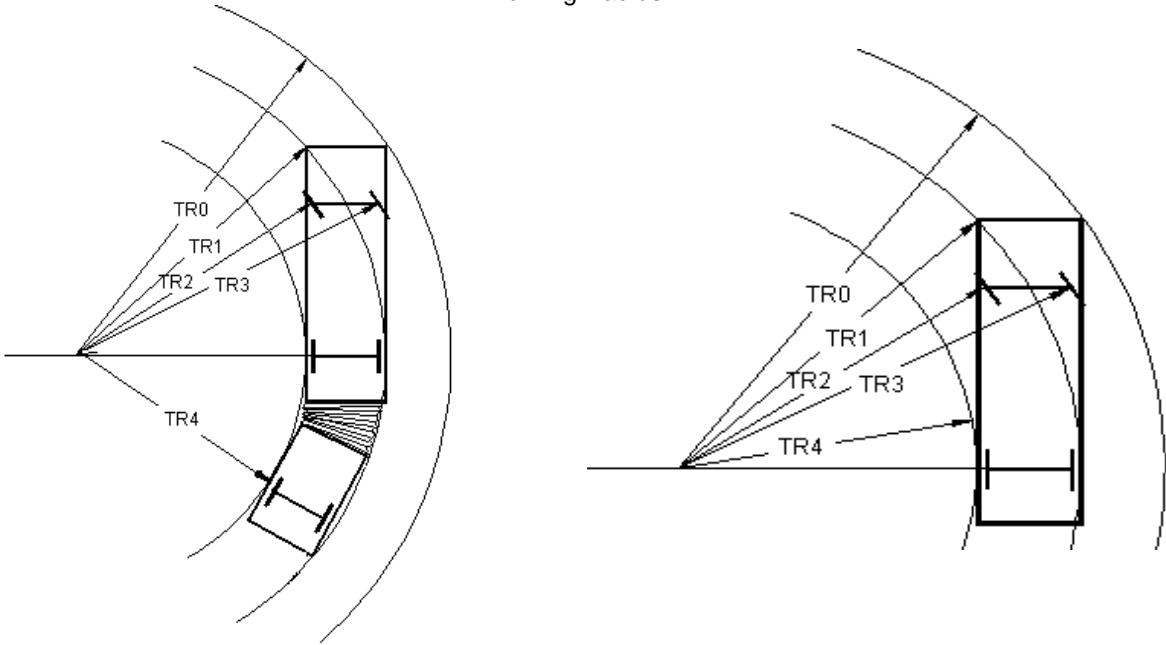

**TS 37. Brakes**

**TS 37.1 Service Brake**

The four wheel disc brakes shall be self-adjusting.

**TS 37.2 Actuation**

Service brakes shall be controlled and actuated by a compressed air system. Force to activate the brake pedal control shall be an essentially linear function of the bus deceleration rate and shall not exceed 70 pounds at a point 7 inches above the heel point of the pedal to achieve maximum braking. The heel point is the location of the driver’s heel when foot is rested flat on the pedal and the heel is touching the floor or heel pad of the pedal. A microprocessor controlled Automatic Braking System (ABS) shall be provided. The microprocessor for the ABS system shall be protected yet in an accessible location to allow for ease of service. The total braking effort shall be distributed between all wheels in such a ratio as to ensure equal friction material wear rate at all wheel locations.

### **TS 37.3 Friction Material**

The brake linings shall be made of non-asbestos material. In order to aid maintenance personnel in determining extent of wear, a provision such as a scribe line or a chamfer indicating the thickness at which replacement becomes necessary shall be provided on each brake lining. The complete brake lining wear indicator shall be clearly visible from the hoist or pit without removing backing plates.

### **TS 37.4 Hubs and Drums/Discs**

Replaceable wheel bearing seals shall run on replaceable wear surfaces or be of an integral wear surface sealed design. Wheel bearing and hub seals shall not leak or weep lubricant for 100,000 miles when running on the design operating profile.

The bus shall be equipped with disc brakes on both the front and rear axles and the brake discs shall allow machining the surfaces up to ¼ inch each side to obtain smooth surfaces.

The brake system material and design shall be selected to absorb and dissipate heat quickly so the heat generated during braking operation does not glaze brake linings. The heat generated shall not increase the temperature of tire beads and wheel contact area to more than that allowed by the tire manufacturer.

### **TS 37.5 Parking/Emergency Brake**

The parking brake shall be a spring-operated system, actuated by a valve that exhausts compressed air to apply the brakes. The parking brake may be manually enabled when the air pressure is at the operating level per FMVSS 121. An emergency brake release shall be provided to release the brakes in the event of automatic emergency brake application. The parking brake valve button will pop out when air pressure drops below requirements of FMVSS 121. The driver shall be able to manually depress and hold down the emergency brake release valve to release the brakes and maneuver the bus to safety. Once the operator releases the emergency brake release valve, the brakes shall engage to hold the bus in place.

## **TS 38. Interlocks**

### **TS 38.1 Passenger Door Interlocks**

To prevent opening rear passenger doors while the bus is in motion, a speed sensor shall be integrated with the door controls to prevent the rear door from being enabled or opened unless the bus speed is less than 2 mph.

To preclude movement of the bus, an accelerator interlock shall lock the accelerator in the closed position, and a brake interlock shall engage the service brake system to stop movement of the bus when the driver's door control is moved to an open position, or the rear door panel is opened more than 3 in. from the fully closed position (as measured at the leading edge of the door panel). The interlock engagement shall bring the bus to a smooth stop and will be capable of holding a fully loaded bus on a 6 percent grade, until the interlocks are released. These interlock functions shall be active whenever the vehicle Master Run Switch is in any run position.

All door systems employing brake and accelerator interlocks shall be supplied with supporting failure mode effects analysis (FEMA) documentation, which demonstrates that failure modes are of a failsafe type, thereby never allowing the possibility of release of interlock while an interlocked door is in an unsecured condition, unless the door master switch has been actuated to intentionally release the interlocks.

The brake interlock regulator shall be non-adjustable.

## TS 39. Pneumatic System

### TS 39.1 General

The bus air system shall operate the air-powered accessories and the braking system with reserve capacity. New buses shall not leak down more than 5 psi as indicated on the instrument panel mounted air gauges, within 15 minutes from the point of governor cut-off.

Provision shall be made to apply shop air to the bus air systems using a quick-disconnect fitting. A quick disconnect fitting specified herein shall be easily accessible and located in the drive system compartment and near the front bumper area for towing. Retained caps shall be installed to protect fitting against dirt and moisture when not in use. A quarter (1/4) turn manual shutoff valve shall be added behind the fitting. Air for the compressor shall be filtered separately and specifically for the air compressor/intake.

The air system shall be protected by a pressure relief valve set at 150 psi and shall be equipped with check valve and pressure protection valves to assure partial operation in case of line failures.

### TS 39.2 Air Compressor

The air compressor shall be electrically driven and shall be sized to charge the air system from 40 psi to the governor cut-off pressure in less than 4 minutes. A piston type air compressor is not acceptable. Air compressor shall have constant positive intake pressure or be unloaded through the air dryer system.

### TS 39.3 Air Lines and Fittings

Air lines, except necessary flexible lines, shall conform to the installation and material requirements of SAE Standard J1149 for copper tubing with standard, brass, flared or ball sleeve fittings, or SAE Standard J844 for nylon tubing if not subject to temperatures over 200 °F. The air on the delivery side of the compressor where it enters nylon housing shall not be above the maximum limits as stated in SAE J844. Nylon tubing shall be installed in accordance with the following color-coding standards:

- **Green:** Indicates primary brakes and supply
- **Red:** Indicates secondary brakes
- **Brown:** Indicates parking brake
- **Yellow:** Indicates compressor governor signal
- **Black:** Indicates doors, hill hold, and accessories

Line supports shall prevent movement, flexing, tension, strain and vibration. Copper lines shall be supported to prevent the lines from touching one another or any component of the bus. To the extent practicable and before installation, the lines shall be pre-bent on a fixture that prevents tube flattening or excessive local strain. Copper lines shall be bent only once at any point, including pre-bending and installation. Rigid lines shall be supported at no more than 5ft intervals. Nylon lines may be grouped and are supported at 30 in. intervals or less.

The compressor discharge line between power plant and body-mounted equipment shall be a flexible Teflon hose with a braided stainless steel jacket. Other lines necessary to maintain system reliability shall be flexible Teflon hose with a braided stainless steel jacketed fittings. They use standard SAE or JIC brass or steel, flanged, swivel-type fittings. Flexible hoses shall be as short as practicable and individually supported. They shall not touch one another or any part of the bus except for the supporting grommets. Flexible lines shall be supported at 2ft intervals or less.

Air lines shall be clean before installation and shall be installed to minimize air leaks. All air lines shall be routed to prevent water traps to the extent possible. Grommets or insulated clamps shall protect the air lines at all points where they pass through understructure components.

### **TS 39.4 Air Reservoirs**

All air reservoirs shall meet the requirements of FMVSS Standard 121 and SAE Standard J10 and shall be equipped with drain plugs and guarded or flush type drain valves. Major structural members shall protect these valves and any automatic moisture ejector valves from road hazards. Reservoirs shall be sloped toward the drain valve. All air reservoirs shall have drain valves that discharge below floor level with lines routed to eliminate the possibility of water traps and/or freezing in the drain line.

### **TS 39.5 Air System Dryer**

An air dryer shall prevent accumulation of moisture and oil in the air system. The air dryer system shall include a replaceable desiccant bed, electrically heated drain, and activation device. A 2M/3M mechanic shall replace the desiccant in less than 15 minutes.

## **ELECTRICAL, ELECTRONIC AND DATA COMMUNICATION SYSTEMS**

### **TS 40. Overview**

The Electrical System will consist of the vehicle battery systems and all other equipment that generate, distribute and use battery power throughout the vehicle (e.g., drive system batteries, inverters, motor drives, connectors, high voltage fuses, high voltage switches, wiring, relays, and connectors).

Electronics are those components of the electrical system made up of discrete solid-state devices such as transistors, resistors, capacitors and diodes that are part of individual vehicle systems. Electronics also include the integrated circuits that are part of microprocessors that allow individual vehicle systems to process and store data.

The data communication system consists of the bi-directional communications networks that electronic devices use to share data with other electronic devices and systems. Communication networks are essential to integrating electronic functions, both onboard the vehicle and off.

Data communications systems are divided into three levels to reflect the use of multiple data networks.

- **Drivetrain Level:** Components related to the drivetrain including the drive motor, transmission, and anti-lock braking system (ABS), which may include traction control.



- **Information Level:** Components whose primary function is the collection, control or display of data that is not necessary to the safe drivability of the vehicle (i.e., those functions, that when inoperable, will still allow the vehicle to operate). These components typically consist of those required for automatic vehicle location (AVL) systems, destination signs, fare boxes, passenger counters, radio systems, automated voice and signage systems, video surveillance, and similar components.
- **Multiplex Level:** Electrical devices controlled through input/output signals such as discrete, analog, and serial data information (i.e., on/off switch inputs, relay or relay control outputs). Multiplexing is used to control components not typically found on the Drivetrain or Information Levels such as lights, wheelchair lifts, doors, and heating, ventilation, air conditioning (HVAC) systems.

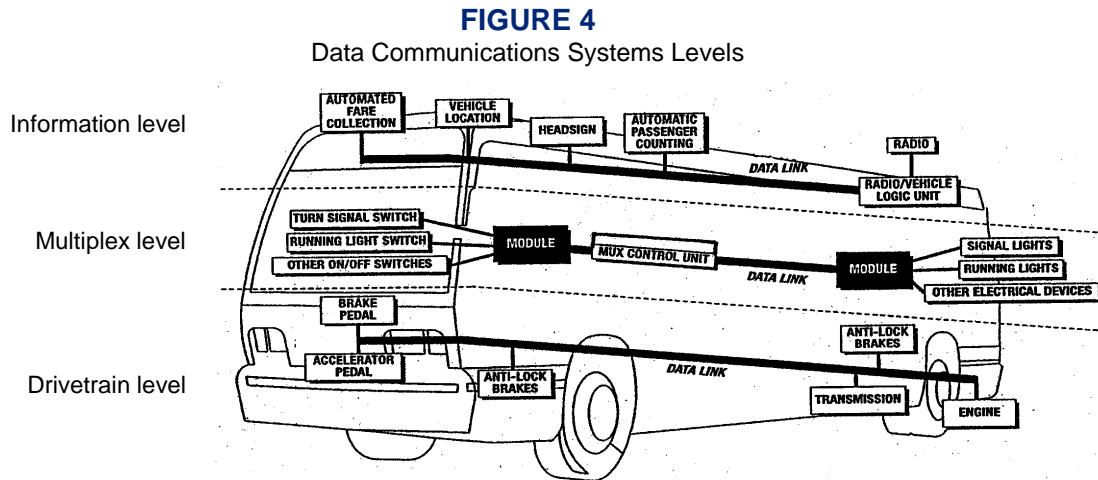

## TS 40.1 Modular Design

Design of the electrical, electronic and data communication systems shall be modular so that each major component, apparatus panel, or wiring bundle is easily separable with standard hand tools or by means of connectors. Each module, except the main body wiring harness, shall be removable and replaceable in less than 1 hour by a 3M mechanic.

Power plant wiring shall be an independent wiring module. Replacement of the drive system compartment wiring module(s) shall not require pulling wires through any bulkhead or removing any terminals from the wires.

## TS 41. Environmental and Mounting Requirements

The electrical system and its electronic components shall be capable of operating in the area of the vehicle in which they will be installed, as recommended in SAE J1455.

Electrical and electronic equipment is not located in an environment that will reduce the performance or shorten the life of the component or electrical system when operating within the design operating profile. No vehicle component shall be able to generate, or be affected by, electromagnetic interference or radio-frequency interference (EMI/RFI) that can disturb the performance of electrical/electronic equipment as defined in SAE J1113 and UNECE Council Directive 95/54 (R10).

The Agency shall follow recommendations from bus manufacturers and subsystem suppliers regarding methods to prevent damage from voltage spikes generated from welding, jumpstarts, shorts, etc.

## **TS 41.1 Hardware Mounting**

The mounting of the hardware shall not be used to provide the sole source ground, and all hardware is isolated from potential EMI/RFI, as referenced in SAE J1113.

All electrical/electronic hardware mounted in the interior of the vehicle shall be inaccessible to passengers and hidden from view unless intended to be viewed. The hardware shall be mounted in such a manner as to protect it from splash or spray.

All electrical/electronic hardware mounted on the exterior of the vehicle that is not designed to be installed in an exposed environment shall be mounted in a sealed enclosure.

All electrical/electronic hardware and its mounting complies with the shock and vibration requirements of SAE J1455.

## **TS 42. General Electrical Requirements**

### **TS 42.1 Batteries**

#### **TS 42.1.1 Low-Voltage Batteries (24V)**

The system shall supply a nominal 12V and/or 24V of direct current (DC). Batteries, except those used for auxiliary power, shall be easily accessible for inspection and service from the outside of the vehicle only.

Two (2) Group 31 Series deep cycling maintenance free battery units shall be provided. Each battery shall have a minimum of 700 cold cranking amps. Each battery shall have a purchase date no more than one year from date of release for shipment to the customer.

The batteries shall be equipped with a single switch for disconnecting both 12V and 24V power

#### **TS 42.1.2 Battery Cables**

The positive and negative battery terminal ends and cables shall be color-coded with red for the primary positive, black for negative, and another color for any intermediate voltage cables. Heat shrink at the terminal ends of the aforementioned colors may be used on battery cables with black insulation. Battery cables shall be flexible and sufficiently long to reach the batteries with tray in the extended position without stretching or pulling on any connection and shall not lie directly on top of the batteries. Except as interrupted by the master battery switch(s), battery wiring shall be continuous cables with connections secured by bolted terminals; and shall conform to specification requirements of SAE J1127 –Type SGT or SGX and SAE Recommended Practice J541.

#### **TS 42.1.3 JumpStart**

A 24V Anderson style jump-start connector or approved equal, shall be provided, equipped with dust cap and adequately protected from moisture, dirt and debris.

#### **TS 42.1.4 Battery Compartment**

The battery compartment shall prevent accumulation of snow, ice and debris on top of the batteries and shall be vented and self-draining. It shall be accessible only from the outside of the vehicle. All components within the battery compartment, and the compartment itself, shall be protected from damage or corrosion from the electrolyte. The inside surface of the battery compartment's access door shall be electrically insulated, as required, to prevent the battery terminals from shorting on the door if the door is damaged in an accident or if a battery comes loose.

### **TS 42.1.5 Auxiliary Electronic Power Supply**

If required, gel-pack, or any form of encased batteries used for auxiliary power, are allowed to be mounted on the interior of the vehicle if they are contained in an enclosed, non-airtight compartment and accessible only to maintenance personnel. This compartment shall contain a warning label prohibiting the use of lead-acid batteries.

### **TS 42.1.6 Master Battery Switch**

A single master switch shall be provided near the battery compartment for the disconnecting of all battery positives (12V & 24V) except for safety devices such as fire suppression system and other systems as specified. The location of the master battery switch shall be clearly identified on the exterior access panel, be accessible in less than 10 seconds for de-activation, and prevent corrosion from fumes and battery acid when the batteries are washed off or are in normal service.

Turning the master switch “OFF”, with the power plant operating, shall not damage any component of the electrical system. The master switch shall be capable of carrying and interrupting the total circuit load.

### **TS 42.1.7 Low-Voltage Generation and Distribution**

The Propulsion System Batteries shall maintain the charge on the low voltage batteries.

The vehicle shall be equipped with a 300-AMP minimum, 24 VDC DC-DC power converter, suitably rated to handle the electrical load requirements. The high output DC amps shall be achieved at the DC-DC Power converter’s designed maximum output.

Power distribution shall be accomplished by means of conductive bus-bars, terminal strips, or stud-terminal blocks that are sized for the cumulative total current of connected branch circuits and for the physical securement of them. One such arrangement is to exist for each voltage potential level and ground. These points to all equipment requiring dedicated power and ground wiring to the batteries shall be accomplished by using power bus bars consisting of either a solid copper bar or heavy-duty terminal strip. One bus bar for each voltage potential, including ground, shall be located as close, electrically speaking, to the source of the potential (the battery source) as physically practical, based on recommendations of the vehicle manufacturer. Terminal stack-up is not to exceed a quantity of four (4) per each individual screw, post, or stud block. All cabling and wiring associated with an individual circuit will be sized to ensure a voltage drop figure of no more than 5% of the source voltage. This figure is to cover the total loop from source potential to source ground.

### **TS 42.1.8 Circuit Protection**

All branch circuits shall be protected by circuit breakers or fuses sized to the requirements of the load. The circuit breakers or fuses shall be easily accessible for authorized personnel. Fuses shall be used only where it can be demonstrated that circuit breakers are not practicable. Any manually re-settable circuit breakers shall provide visible indication of open circuits.

Fuses shall be located adjacent to power source, and in a fuse block except as specifically approved by the customer after contract award.

Circuit breakers or fuses shall be sized to a minimum of 15 percent larger than the total circuit load current. The current rating for the wire used for each circuit must exceed the size of the circuit protection being used.

## TS 42.2 Grounds

The batteries shall be grounded to the vehicle chassis/frame at one location only, as close to the batteries as possible. No more than four ground connections shall be made per ground stud. Electronic equipment requiring an isolated ground to the battery (i.e., electronic ground) shall not be grounded to the chassis.

## TS 42.3 Low Voltage/Low Current Wiring and Terminals

All power and ground shall conform to specification requirements of SAE Recommended Practice J1127, J1128 and J1292 for type GXL and SXL wiring. Double insulation shall be maintained as close to the junction box, electrical compartment or terminals as possible.

Wiring shall be grouped, labeled and color-coded. Wiring harnesses shall not contain wires of different voltage classes unless all wires within the harness are insulated for the highest voltage present in the harness. Kinking, grounding at multiple points, stretching, and exceeding minimum bend radius shall be prevented.

Strain-relief fittings shall be provided at all points where wiring enters electrical compartments. Grommets or other protective material shall be installed at points where wiring penetrates metal structures outside of electrical enclosures. Wiring supports shall be protective and non-conductive at areas of wire contact and will not be damaged by heat, water, solvents or chafing.

To the extent practicable, wiring shall not be located in environmentally exposed locations under the vehicle. Wiring and electrical equipment necessarily located under the vehicle shall be insulated from water, heat, corrosion and mechanical damage. Where feasible, front-to-rear electrical harnesses shall be installed above the window line of the vehicle.

All wiring harnesses over 5 ft. long and containing at least five wires shall include 10 percent (minimum one wire) excess wires for spares. This requirement for spare wires does not apply to data links and communication cables. Wiring harness length shall allow end terminals to be replaced twice without pulling, stretching or replacing the wire. Terminals shall be crimped to the wiring according to the connector or manufacturer's recommendations for techniques and tools. All cable connectors shall be locking type, keyed and sealed, unless enclosed in watertight cabinets or the vehicle interior. Pins shall be removable, crimp contact type, of the correct size and rating for the wire being terminated. Unused pin positions are sealed with sealing plugs. Adjacent connectors shall either use different inserts or different insert orientations to prevent incorrect connections.

Terminals shall be crimped, corrosion-resistant and full ring type or interlocking lugs with insulating ferrules. When using pressure type screw terminal strips, only stranded wire shall be used. Insulation clearance shall ensure that wires have a minimum of "visible clearance" and a maximum of two times the conductor diameter or 1/16 in., whichever is less. When using shielded or coaxial cable, upon stripping of the insulated, the metallic braid shall be free from frayed strands that can penetrate the insulation of the inner wires.

Ultra-sonic and T-splices may be used with 8 AWG or smaller wire. When a T-splice is used, it shall meet these additional requirements:

- It shall include a mechanical clamp.
- The wire shall support no mechanical load in the area of the splice.
- The wire shall be supported to prevent flexing.

All splicing shall be staggered in the harness. Wiring located in the electric motor compartment shall be routed away from high-heat sources or shielded and/or insulated from temperatures exceeding the wiring and connector operating requirements.

The instrument panel and wiring shall be easily accessible for service from the driver's seat or top of the panel. The instrument panel shall be separately removable and replaceable without damaging the instrument panel or gauges. Wiring shall have sufficient length and routed to permit service without stretching or chafing the wires.

### **TS 42.4 Electrical Components**

All electrical components, including switches, relays, flashers, and circuit breakers, shall be heavy-duty designs with either a successful history of application to heavy-duty vehicles, or design specifications for an equivalent environment. These components shall be replaceable in less than 5 minutes by a 3M mechanic.

All electric motors shall be either heavy-duty brushless type where practical, or have a constant duty rating of no less than 40,000 hours. All electric motors shall be easily accessible for servicing.

### **TS 42.5 Electrical Compartments**

All relays, controllers, flashers, circuit breakers, and other electrical components shall be mounted in easily accessible electrical compartments. All compartments exposed to the outside environment shall be corrosion resistant and sealed. The components and circuits in each electrical compartment shall be identified and their location permanently recorded on a drawing attached to the inside of the access panel or door. The drawing shall be protected from oil, grease, fuel, and abrasion.

Junction boxes shall have laminated schematics or the front compartment shall be completely serviceable from the operator's seat, vestibule, or from outside.

## **TS 43. General Electronic Requirements**

If an electronic component has an internal real-time clock, it shall provide its own battery backup to monitor time when battery power is disconnected, and/or it may be updated by a network component. If an electronic component has an hour meter, it shall record accumulated service time without relying on battery backup.

The Contractor shall ensure that their electronic equipment is self-protecting in the event of shorts in the cabling, and also in over-voltage and reverse polarity conditions. If an electronic component is required to interface with other components, it shall not require external pull-up and/or pull-down resistors. Where this is not possible, the use of pull-up or pull-down resistor must be limited as much as possible and if used, must be easily accessible and labeled appropriately.

### **TS 43.1 Wiring and Terminals**

Kinking, grounding at multiple points, stretching and reducing the bend radius below the manufacturer's recommended minimum shall not be permitted.

#### **TS 43.1.1 Discrete I/O(Inputs/Outputs)**

All wiring to I/O devices, either at the harness level or individual wires, shall be labeled, stamped or color-coded in a fashion that allows unique identification at a spacing not exceeding 4 in. Wiring for each I/O device shall be bundled together. If the I/O terminals are the same voltages, then jumpers may be used to connect the common nodes of each I/O terminal

#### **TS 43.1.2 Shielding**

All wiring that requires shielding shall meet the following minimum requirements. A shield shall be generated by connecting to a ground, which is sourced from a power distribution bus bar or chassis. A shield shall be connected at one location only, typically at one end of the cable. However certain standards or special requirements, such as SAE J1939 or RF applications, have separate shielding techniques that shall also be used as applicable.

**NOTE:** A shield grounded at both ends forms a ground loop, which can cause intermittent control or faults.

When using shielded or coaxial cable, upon stripping of the insulation, the metallic braid shall be free from frayed strands, which can penetrate the insulation of the inner wires. To prevent the introduction of noise, the shield shall not be connected to the common side of a logic circuit.

### **TS 43.1.3 Communications**

The data network cabling shall be installed according to the selected protocol requirements. The physical layer of all network communication systems shall not be used for any purpose other than communication between the system components, unless provided for in the network specifications.

Communications networks that use power line carriers (e.g., data modulated on a 24V power line) shall meet the most stringent applicable wiring and terminal specifications.

### **TS 43.1.4 Radio Frequency (RF)**

RF components, such as radios, video devices, cameras, global positioning systems (GPS), etc., shall use coaxial cable to carry the signal. All RF systems require special design consideration for losses along the cable. Connectors shall be minimized, since each connector and crimp has a loss that will attribute to attenuation of the signal. Cabling should allow for the removal of antennas or attached electronics without removing the installed cable between them. If this cannot be done, then a conduit of sufficient size shall be provided for ease of attachment of antenna and cable assembly. The corresponding component vendors shall be consulted for proper application of equipment, including installation of cables.

### **TS 43.1.5 Audio**

Cabling used for microphone level and line level signals shall be 22AWG minimum with shielded twisted pair. Cabling used for amplifier level signals shall be 18AWG minimum.

## **TS 44. Multiplexing**

### **TS 44.1 General**

The primary purpose of the multiplexing system is control of components necessary to operate the vehicle. This is accomplished by processing information from input devices and controlling output devices through the use of an internal logic program.

Versatility and future expansion shall be provided for by an expandable system architecture. The multiplex system shall be capable of accepting new inputs and outputs through the addition of new modules and/or the utilization of existing spare inputs and outputs. All like components in the multiplex system shall be modular and interchangeable with self-diagnostic capabilities. The modules shall be easily accessible for troubleshooting electrical failures and performing system maintenance. Multiplex input/output modules shall use solid-state devices to provide extended service life and individual circuit protection.

Ten percent of the total number of inputs and outputs, or at least one each at each zone location shall be designated as spares.

### **TS 44.2 System Configuration**

Multiplexing must be centralized. A centralized system shall consist of several modules connected to form a control network. The system shall be managed by a master vehicle controller. It provides the configurability

and the control required to integrate all systems on the bus. The vehicle shall be equipped with a Continental VDO KIBES-32 multiplexing system, or approved equal.

### **TS 44.2.1 I/O Signals**

The input/output for the multiplex system may contain four types of electrical signals: discrete, modulating, analogue, serial data.

Discrete signals shall reflect the on/off status of switches, levers, limit switches, lights, etc. Analog signals reflect numerical data as represented by a voltage signal (for example 0–5V) or resistance signal (for example NTC thermistor). Both types of analog signals shall represent the status of variable devices such as rheostats, op-amps, potentiometers, temperature probes, etc.

## **TS 45. Data Communications**

### **TS 45.1 General**

All data communication networks shall be in accordance with a nationally recognized interface standard such as those published by SAE, IEEE, or ISO.

Any electronic vehicle components used on a network shall be conformance tested to the corresponding network standard.

The vehicle shall be designed with a fully integrated diagnostic system where the master vehicle controller monitors and records the fault status from all systems on the main PCAN network as well as fault status from the multiplex devices. This shall include subsystems such as the powertrain controller, cooling system, ABS system, HVAC system, battery management system and other power devices. This diagnostic system shall also include the detection of loss of communication of all individual devices on the PCAN and MCAN network.

All faults shall be recorded, time stamped, odometer stamped and assigned a priority level based on the severity of the fault. A diagnostic tool shall also serve as a troubleshooting guide to aid in quick resolution of individual faults.

The following information shall be displayed when using the instrument cluster and diagnostic tool:

- Fault status (active or previously recorded and inactive)
- Identifying number (SPN and FMI according to J1939)
- General description of part faulted (SPN description)
- Type of fault (FMI description; i.e. value to high, to low, data erratic, loss of communication)
- Mux input or output pin where fault was detected or system where fault was originated
- Time, date and odometer reading at time of fault

A vehicle data logger must be provided to monitor J1939 communications system. It shall provide:

- Continuous monitoring and recording of the PCAN J1939 data bus.
- Software that can generate structured reports using the gathered data.
- Software to create tools for incident definition, data import/export, analysis and presentation.
- Software for recording of user selected J1939 fault codes.

### **TS 45.2 Drivetrain Level**

Drivetrain components, consisting of the drive motor inverters, regenerative braking system, anti-lock braking system and all other related components, shall be integrated and communicate fully with respect to vehicle

operation with data using SAE Recommended Communications Protocols such as J1939. Drivetrain components shall be powered by a supply voltage to ensure data communication among components exists when the vehicle ignition is switched to the “on” position.

### **TS 45.2.1 Diagnostics, Fault Detection and Data Access**

Drivetrain performance, maintenance and diagnostic data, and other electronic messages shall be formatted and transmitted on the communications network.

The drivetrain level shall have the ability to record abnormal events in memory and provide diagnostic codes and other information to service personnel. These codes shall be available from the driver’s digital display or on the diagnostic tool. The communication ports shall be located at the front and rear interior of the vehicle.

### **TS 45.2.2 Programmability (Software)**

The drivetrain level components shall be programmable by the Agency with limitations as specified by the subsystem Supplier.

## **TS 45.3 Multiplex Level**

### **TS 45.3.1 Data Access**

At a minimum, information shall be made available via communication ports on the multiplex system at the front and rear interior of the vehicle. The location of the communication ports shall be easily accessible.

### **TS 45.3.2 Diagnostics and Fault Detection**

The multiplex system shall have a proven method of determining its status (system health and input/output status) and detecting either active (Online) or inactive (Offline) faults through the use of on-board visual/audible indicators.

In addition to the indicators, the system shall employ an advanced diagnostic and fault detection system, which shall be accessible via the diagnostic tool. The diagnostic tool shall have the ability to check logic function.

### **TS 45.3.3 Programmability (Software)**

The multiplex system shall have security provisions to protect its software from unwanted changes. This shall be achieved through any or all of the following procedures: password protection, limited distribution of the configuration software, limited access to the programming tools required to change the software, and hardware protection that prevents undesired changes to the software.

Provisions for programming the multiplex system shall be possible through the diagnostic tool. The multiplex system shall have proper revision control to insure that the hardware and software is identical on each vehicle equipped with the system. Revision control shall be provided by all of the following: hardware component identification where labels are included on all multiplex hardware to identify components; hardware series identification where all multiplex hardware displays the current hardware serial number and firmware revision employed by the module; and software revision identification where all copies of the software in service displays the most recent revision number, and a method of determining which version of the software is currently in use in the multiplex system.



## **TS 45.4 Electronic Noise Control**

Electrical and electronic sub systems and components on all buses shall not emit electromagnetic radiation that will interfere with on-board systems, components or equipment, telephone service, radio or TV reception, or violate regulations of the Federal Communications Commission.

Electrical and electronic sub systems on the coaches shall not be affected by external sources of RFI/EMI. This includes, but is not limited to, radio and TV transmission, portable electronic devices including computers in the vicinity of or onboard the buses, AC or DC power lines and RFI/EMI emissions from other vehicles.

## **DRIVER PROVISIONS, CONTROLS AND INSTRUMENTATION**

### **TS 46. Driver's Area Controls**

#### **TS 46.1 General**

In general when designing the driver's area, it is recommended that SAE J833, "Human Physical Dimensions," be used.

Switches and controls shall be divided into basic groups and assigned to specific areas, in conformance with SAE Recommended Practice J680, Revised 1988, "Location and Operation of Instruments and Controls in Motor Truck Cabs," and be essentially within the hand reach envelope described in SAE Recommended Practice J287, "Driver Hand Control Reach."

#### **TS 46.2 Glare**

The driver's work area shall be designed to minimize glare to the extent possible. Objects within and adjacent to this area shall be matte black or dark gray in color wherever possible to reduce the reflection of light onto the windshield. The use of polished metal and light-colored surfaces within and adjacent to the driver's area shall be avoided.

#### **TS 46.3 Visors/Sun Shades**

##### **Front and Side Sun Shade/Visor**

Adjustable sun visor(s) shall be provided for the driver's windshield and the driver's side window. Visors shall be shaped to minimize light leakage between the visor and windshield pillars. Visors shall store out of the way and shall not obstruct airflow from the climate control system or interfere with other equipment, such as the radio handset or the destination control. Deployment of the visors shall not restrict vision of the rearview mirrors. Visor adjustments shall be made easily by hand with positive locking and releasing devices and shall not be subject to damage by over-tightening. Sun visor construction and materials shall be strong enough to resist breakage during adjustments. Visors may be transparent, but shall not allow a visible light transmittance in excess of 10 percent. Visors, when deployed, shall be effective in the driver's field of view at angles more than 5 degrees above the horizontal.

#### **TS 46.4 Driver's Controls**

Frequently used controls must be in easily accessible locations. These include the door control, kneel control, windshield wiper/washer controls, ramp, and lift and run switch. Any switches and controls necessary for the safe operation of the bus shall be conveniently located and shall provide for ease of operation. They shall be identifiable by shape, touch and permanent markings. Controls also shall be located so that passengers may not easily tamper with control settings.

All panel-mounted switches and controls shall be marked with easily read identifiers. Graphic symbols shall conform to SAE Recommended Practice J2402, “Road Vehicles – Symbols For Controls, Indicators, and Tell Tales,” where available and applicable. Color of switches and controls shall be dark with contrasting typography or symbols.

Mechanical switches and controls shall be replaceable, and the wiring at these controls shall be serviceable from a convenient location. Switches, controls and instruments shall be dust- and water-resistant.

### **TS 46.5 Normal Bus Operation Instrumentation and Controls**

The following list identifies bus controls used to operate the bus. These controls are either frequently used or critical to the operation of the bus. They shall be located within easy reach of the operator. The operator shall not be required to stand or turn to view or actuate these controls unless specified otherwise.

Systems or components monitored by onboard diagnostics system shall be displayed in clear view of the operator and provide visual and/or audible indicators. The intensity of indicators shall permit easy determination of on/off status in bright sunlight but not cause a distraction or visibility problem at night. All indicators shall be illuminated using backlighting.

The indicator panel shall be located in the instrument cluster mounted in the center of the driver’s dash, within easy view of the operator instrument panel. All indicators shall have a method of momentarily testing their operation. The audible alarm shall be tamper-resistant and shall have an outlet level between 80 and 83 dBA when measured at the location of the operator’s ear.

On-board displays visible to the operator shall be limited to indicating the status of those functions described herein that are necessary for the operation of the bus. All other indicators needed for diagnostics and their related interface hardware shall be concealed and protected from unauthorized access. **Table 5** represents instruments and alarms. The intent of the overall physical layout of the indicators shall be in a logical grouping of systems and severity nature of the fault.

**TABLE 5**  
Transit Bus Instruments and Alarms

<b>Device</b>	<b>Description</b>	<b>Location</b>	<b>Function</b>	<b>Visual/ Audible</b>
Master run switch	Rotary, four-position detent	Side console	Master control for bus, off, day run, night run and clearance ID lights	
Vehicle start	Approved momentary switch	Side console	Activates the High Voltage System	
Drive selector	Three illuminated push buttons	Side console	Provides selection of propulsion: forward, reverse and neutral	Gear selection
HVAC	Switch or switches to control HVAC	Side console	Permits selection of passenger ventilation: off, cool, heat, low fan, high fan or full auto with on/off only	
Driver’s ventilation	Rotary, four-position detent	Dash left wing	Permits supplemental ventilation: fan off, low, medium, or high	

**TABLE 5**  
Transit Bus Instruments and Alarms

<b>Device</b>	<b>Description</b>	<b>Location</b>	<b>Function</b>	<b>Visual/ Audible</b>
Defroster fan	Rotary, four-position detent	Dash left wing	Permits defroster: fan off, low, medium or high	
Defroster temperature	Rotary, four-position detent	Dash left wing	Adjusts defroster temperature	
Windshield wiper	One-variable rotary position operating both wipers	Dash left wing	Variable speed control of left and right windshield wipers	
Windshield washer	Push button	Dash left wing	Activates windshield washers	
Dash panel lights	Push button	Main display	Provides adjustment for light intensity in night run and day run position	
Interior lights	Three-position switch	Side console	Selects mode of passenger compartment lighting: low, off, high	
Front door ramp enable	Two-position switch	Dash right wing	Permits ramp activation from front door area	
Front door ramp	Three-position momentary switch	Dash right wing	Permits deploy and stow of front ramp	Amber light; exterior alarm
Front kneel	Three-position momentary switch	Dash right wing	Permits kneeling activation and raise and normal at front door remote location	Amber dash indicator; exterior alarm
Silent alarm	Recessed push button, NO and NC contacts momentary	Side console	Activates emergency radio alarm at dispatch and permits covert microphone and/or enables destination sign emergency message	
Video system event switch	Momentary on/off	Side console	Triggers event equipment,	
Left remote mirror	Four-position toggle type	Side console	Permits two-axis adjustment of left exterior mirror	
Right remote mirror	Four-position toggle type	Side console	Permits two-axis adjustment of right exterior mirror	
Mirror heater	Switch activated	Side console	Permits heating of outside mirrors when required	

**TABLE 5**  
Transit Bus Instruments and Alarms

Device	Description	Location	Function	Visual/ Audible
Passenger door control	Two momentary push buttons	Side console	Permits open/close control of front and rear passenger doors	Red light on push button indicating door open, amber light in instrument cluster indicating door open
Engine shutdown override	Momentary switch with operation protection	Side console	Permits driver to override auto engine shutdown	Continuous buzzer
Hazard flashers	Two-position switch	Dash right wing	Activates emergency flashers	Two green left/right indicator lights
Farebox interface	Farebox coach operator interface panel	Near farebox	Facilitates driver interaction with farebox system	LCD display
Destination sign interface	Destination sign interface panel	Over head	Facilitates driver interaction with destination sign system, manual entry	LED display
Turn signals	Momentary push button (two required) raised from other switches	Left foot panel	Activates left and right turn signals	Two green left/right indicators and audible indicator
PA manual	Momentary push button	Side console and left foot panel	Permits driver to manually activate public address microphone	
High beam	Detented push button	Left foot panel	Permits driver to toggle between low and high beam	Blue light
Parking brake	Pneumatic PPV	Side console	Permits driver to apply and release parking brake	Red light
Master door/interlock	Two-position switch	Out of operator's reach	Permits driver override to disable door and brake/throttle interlock	Red light and continuous buzzer
Stop request acknowledge	Push button momentary	Dash left wing	Permits driver to acknowledge stop requested condition	
Speedometer	Speedometer, odometer, and diagnostic capability	Dash center panel	Visual indication of speed and distance traveled, accumulated vehicle mileage, fault condition display	Analog dial
Door obstruction	Sensing of door obstruction	Dash center	Indication of rear door sensitive edge activation	Yellow symbol and buzzer

**TABLE 5**  
Transit Bus Instruments and Alarms

Device	Description	Location	Function	Visual/ Audible
Door ajar	Door not properly closed	Dash center	Indication of rear door not properly closed	Yellow light
Low system air pressure	Sensing low primary and secondary air tank pressure	Dash center	Indication of low air system pressure	Buzzer and red light
ABS indicator	Detects system status	Dash center	Displays system failure	Amber light
HVAC indicator	Detects system status	Dash center	Displays system failure	Amber or red light
Charging system indicator (12/24 V)	Detect charging system status	Dash center	Detects no charge condition and detects battery high, low, imbalance and no charge condition	Red or yellow light based on condition
Bike rack deployed indicator	Detects bike rack position	Dash center	Indication of bike rack not being in fully stowed position	Amber light
High Voltage battery system state of charge	Analog gauge and digital display	Dash center	Indication of high voltage battery system state of charge	Analog dial and digital bar
Active charge/regeneration and power draw	Analog gauge and digital display	Dash center	Indication of electric regeneration, charging and power draw	Analog dial and digital bar

## TS 46.6 Driver Foot Controls

Accelerator and brake pedals shall be designed for ankle motion. Foot surfaces of the pedals shall be faced with wear-resistant, nonskid, replaceable material.

### TS 46.6.1 Pedal Angle

The vertical angle of the accelerator and brake pedals shall be determined from a horizontal plane regardless of the slope of the cab floor. The accelerator and brake pedals shall be positioned at an angle of 40 to 45 degrees at the point of initiation of contact and extend downward to an angle of 20 to 25 degrees at full throttle.

The location of the brake and accelerator pedals shall be determined by the manufacturer, based on space needs, visibility, lower edge of windshield, and vertical H-point. The angle of the accelerator pedal shall be determined from a horizontal plane regardless of the slope of the cab floor.

### TS 46.6.2 Pedal Dimensions and Position

The floor-mounted accelerator pedal shall be 10 to 12 in. long and 3 to 4 in. wide. Clearance around the pedal  
Brake and Accelerator Pedals

#### Brake Pedal

Non-adjustable brake pedal.

## **TS 46.7 Driver Foot Switches**

### **Floor-Mounted Foot Control Platform**

The angle of the turn signal platform shall be determined from a horizontal plane, regardless of the slope of the cab floor. The turn signal platform is angled at a minimum of 10 degrees and a maximum of 37 degrees. It shall be located no closer to the seat front than the heel point of the accelerator pedal.

### **Turn Signal Controls**

Turn signal controls shall be floor-mounted, foot-controlled, water-resistant, heavy-duty, momentary contact switches.

### **Foot Switch Control**

The control switches for the turn signals shall be mounted on an inclined, floor-mounted stainless steel enclosure or metal plate mounted to an incline integrated into the driver's platform, located to the left of the steering column. The location and design of this enclosure shall be such that foot room for the operator is not impeded. The inclined mounting surface shall be skid-resistant. All other signals, including high beam and public address system, shall be in approved locations.

The foot switches shall be UL-listed, heavy-duty type, of a rugged, corrosion-resistant metal construction. The foot switches for the directionals shall be momentary type, while those for the PA system and the high beam shall be latching type. The spacing of the switches shall be such that inadvertent simultaneous deflection of switches is prevented.

## **TS 47. Driver's Amenities**

### **TS 47.1 Coat Hanger**

#### **Coat Hanger**

A suitable hanger shall be installed in a convenient, approved location for the driver's coat.

### **TS 47.2 Drink Holder**

#### **Drink Holder**

A device shall be provided to securely hold the driver's drink container, which may vary widely in diameter. It must be mounted within easy reach of the driver and must have sufficient vertical clearance for easy removal of the container. When the container is in the device, the driver's view of the road must not be obstructed, and leakage from the container must not fall on any switches, gauges or controls.

### **TS 47.3 Storage Box**

#### **Storage Box**

An enclosed driver storage area shall be provided with a positive latching door and/or lock. The minimum size is 1800 cubic in.

## **TS 48. Windshield Wipers and Washers**

### **TS 48.1 Windshield Wipers**

The bus shall be equipped with a windshield wiper for each half of the windshield. At 60 mph, no more than 10 percent of the wiped area shall be lost due to windshield wiper lift. For two-piece windshields, both wipers shall park along the center edges of the windshield glass. For single-piece windshields, wipers shall park along the bottom edge of the windshield. Windshield wiper motors and mechanisms shall be easily accessible

for repairs or service. The fastener that secures the wiper arm to the drive mechanism shall be corrosion-resistant.

## TS 48.2 Windshield Washers

The windshield washer system, when used with the wipers, shall deposit washing fluid evenly and completely wet the entire wiped area.

The windshield washer system shall have a minimum 4-gallon reservoir located for easy refilling from outside of the bus. Reservoir pumps, lines and fittings shall be corrosion-resistant and include a means to determine fluid level.

## TS 49. Driver's Seat

**FIGURE 5**  
Driver's Seat

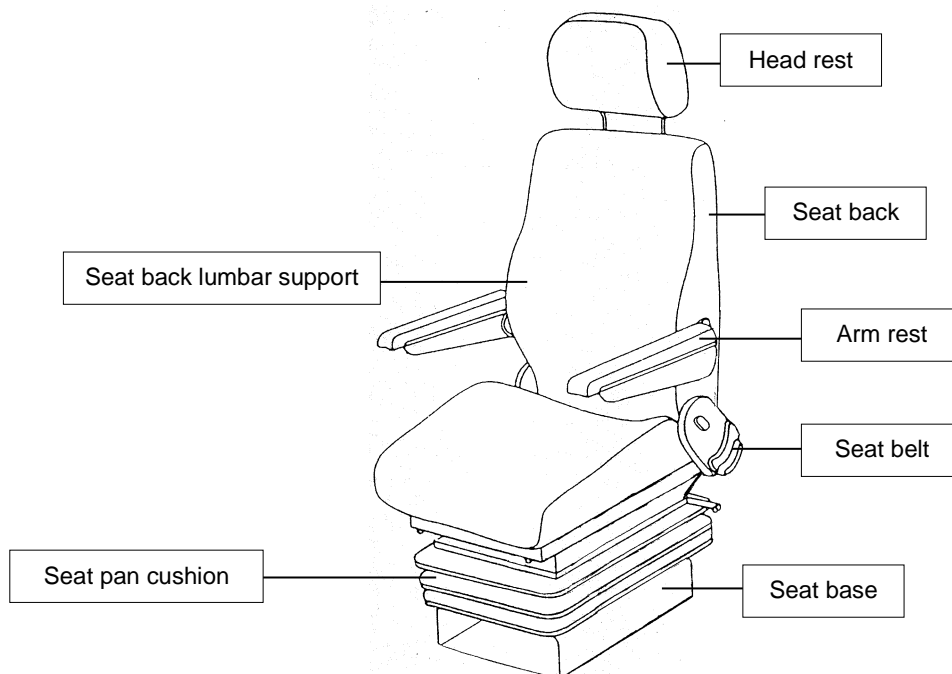

## TS 49.1 Dimensions

The driver's seat shall be comfortable and adjustable so that people ranging in size from a 95th-percentile male to a 5th-percentile female may operate the bus. *Example – Recaro 8HC.21.Y92.VC11*

### TS 49.1.1 Seat Pan Cushion Length

Measurement shall be from the front edge of the seat pan to the rear at its intersection with the seat back. The adjustment of the seat pan length shall be no less than 16.5 in. at its minimum length and no more than 20.5 in. at its maximum length.

### TS 49.1.2 Seat Pan Cushion Slope

Measurement is the slope of the plane created by connecting the two high points of the seat, one at the rear of the seat at its intersection with the seat back and the other at the front of the seat just before it waterfalls downward at the edge. The slope can be measured using an inclinometer and shall be stated in degrees of

incline relative to the horizontal plane (0 deg). The seat pan shall adjust in its slope from no less than plus 12 deg (rearward “bucket seat” incline) to no less than minus 5 deg (forward slope).

### **TS 49.1.3 Seat Base Fore/Aft Adjustment**

Measurement is the horizontal distance from the heel point to the front edge of the seat. The minimum and maximum distances shall be measured from the front edge of the seat when it is adjusted to its minimum seat pan depth (approximately 15 in.). On all low-floor buses, the seat base shall travel horizontally a minimum of 9 in. It shall adjust no closer to the heel point than 6 in. On all high-floor buses, the seat base shall travel a minimum of 9 in. and adjust no closer to the heel point than 6 in.

### **TS 49.1.4 Seat Pan Cushion Width**

Measurement is the horizontal distance across the seat cushion. The seat pan cushion shall be 17 to 21 in. across at the front edge of the seat cushion and 20 to 23 in. across at the side bolsters.

### **TS 49.1.5 Seat Suspension**

The driver’s seat shall be appropriately dampened to support a minimum weight of 380 lbs. The suspension shall be capable of dampening adjustment in both directions.

Rubber bumpers shall be provided to prevent metal-to-metal contact.

### **TS 49.1.6 Seat Back**

#### **Width**

Measurement is the distance between the outermost points of the front of the seat back, at or near its midpoint in height. The seat back width shall be no less than 19 in. Seat back will include dual recliner gears on both sides of the seat.

#### **Height**

Standard height seat back.

### **TS 49.1.7 Headrests**

Adjustable vinyl headrest.

### **TS 49.1.8 Seat Back Lumbar Support**

Measurement is from the bottom of the seat back at its intersection with the seat pan to the top of the lumbar cushioning. The seat back shall provide adjustable-depth lumbar back support with three individual operating lumbar cells within minimum range of 7 to 11 in.

### **TS 49.1.9 Seat Back Angle Adjustment**

The seat back angle shall be measured relative to a level seat pan, where 90 deg is the upright position and 90 deg-plus represents the amount of recline.

The seat back shall adjust in angle from a minimum of no more than 90 deg (upright) to at least 105 deg (reclined), with infinite adjustment in between.

### **TS 49.2 Seat Belt (3-Point w/ Orange Webbing)**

The belt assembly should be an auto-locking retractor (ALR). All seat belts should be stored in automatic retractors. The belts shall be mounted to the seat frame so that the driver may adjust the seat without resetting the seat belt.



Seat belts shall be provided across the driver's lap and diagonally across the driver's chest. The driver shall be able to use both belts by connecting a single buckle on the right side of the seat cushion. 3-pt seatbelts must be emergency locking retractor (ELR) in design.

### **Lap Belt Length**

**72 in.**

The lap belt assembly shall be a minimum of 72 in. in length.

### **TS 49.3 Adjustable Armrest**

One armrest, right side.

### **TS 49.4 Seat Control Locations**

While seated, the driver shall be able to make seat adjustments by hand without complexity, excessive effort or being pinched. Adjustment mechanisms shall hold the adjustments and shall not be subject to inadvertent changes.

### **TS 49.5 Seat Structure and Materials**

#### **Cushions**

Cushions shall be fully padded with at least 3 in. of materials in the seating areas at the bottom and back.

#### **Cushion Materials**

Closed-cell polyurethane (FMVSS 302).

### **TS 49.6 Pedestal**

Powder-coated steel.

### **TS 49.7 Seat Options**

- Seat Alarm

### **TS 49.8 Mirrors**

#### **TS 49.8.1 Exterior Mirrors**

The bus shall be equipped with a corrosion-resistant, outside rearview mirrors mounted with stable supports to minimize vibration. Mirrors shall be firmly attached to the bus to minimize vibration and to prevent loss of adjustment with a breakaway mounting system. Mirrors shall permit the driver to view the roadway along the sides of the bus, including the rear wheels. Mirrors should be positioned to prevent blind spots.

Mirrors shall retract or fold sufficiently to allow bus washing operations but avoid contact with windshield.

#### **Curbside Mirrors**

The curbside rearview mirror shall be mounted so that its lower edge is no less than 76in. above the street surface. A lower mount may be required due to mirror configuration requests.

#### **Remote Adjustment of Curbside Mirror**

The driver shall be able to adjust the curbside mirror remotely while seated in the driving position. The control for remote positioning of the mirror shall be a single switch or device.

### **Street-Side Mirrors**

The driver shall be able to adjust the street-side mirror remotely while seated in the driving position. The control for remote positioning of the mirror shall be a single switch or device. Turn signals shall be integrated into the mirrors

### **TS 49.8.2 Interior Mirrors**

Mirrors shall be provided for the driver to observe passengers throughout the bus without leaving the seat and without shoulder movement. The driver shall be able to observe passengers in the front/entrance and rear/exit areas, anywhere in the aisle, and in the rear seats.

## **WINDOWS**

### **TS 50. General**

A minimum of 10,000 sq in. of window area, including operator and door windows, shall be required on each side of the standard configuration bus.

### **TS 51. Windshield**

The windshield shall permit an operator's field of view as referenced in SAE Recommended Practice J1050. The vertically upward view shall be a minimum of 15 degrees, measured above the horizontal and excluding any shaded band. The vertically downward view shall permit detection of an object 3-1/2 feet high no more than 2 feet in front of the bus. The horizontal view shall be a minimum of 90 degrees above the line of sight. Any binocular obscuration due to a center divider may be ignored when determining the 90-degree requirement, provided that the divider does not exceed a 3-degree angle in the operator's field of view. Windshield pillars shall not exceed 10 degrees of binocular obscuration. The windshield shall be designed and installed to minimize external glare as well as reflections from inside the bus.

The windshield shall be easily replaceable by removing zip-locks from the windshield retaining moldings. Bonded-in-place windshield shall not be used. Winglets may be bonded.

#### **TS 51.1 Glazing**

The windshield glazing material shall have a nominal thickness laminated safety glass conforming to the requirements of ANSI Z26.1 Test Grouping 1A and the Recommended Practices defined in SAE J673.

### **TS 52. Driver's Side Window**

The operator's side window shall be the sliding type, requiring only the rear half of sash to latch upon closing and shall open sufficiently to permit the seated operator to easily adjust the street side outside rearview mirror. When in an open position, the window shall not rattle or close during braking. The operator's side window shall not be bonded in place and shall be easily replaceable. The glazing material shall have a single density tint.

The operator's view, perpendicular through operator's side window glazing, should extend a minimum of 33 inches (840 mm) to the rear of the Heel Point on the accelerator, and in any case must accommodate a 95<sup>th</sup> percentile male operator. The view through the glazing at the front of the assembly should begin not more than 560 mm (26 inches) above the operator's floor to ensure visibility of an under-mounted convex mirror.

The operator's side window glazing material shall have a 1/4 inch nominal thickness laminated safety glass conforming with the requirements of ANSI Z26.1-1996 Test Grouping AS-2 and the Recommended Practices defined in SAE J673.

## TS 53. Side Windows

### TS 53.1 Configuration

Side windows shall not be bonded in place, but shall be easily replaceable without disturbing adjacent windows and shall be mounted so that flexing or vibration from engine operation or normal road excitation is not apparent. All aluminum and steel material will be treated to prevent corrosion.

All side windows shall be easily replaceable without disturbing adjacent windows and shall be mounted so that flexing or vibration from engine operation or normal road excitation is not apparent.

### TS 53.2 Emergency Exit (Egress) Configuration

#### Minimum Egress

All side windows shall be fixed in position, except as necessary to meet the emergency escape requirements.

### TS 53.3 Rear Window

No requirement for rear window.

## HEATING, VENTILATING AND AIR CONDITIONING

### TS 54. Capacity and Performance

The HVAC climate control system shall be capable of controlling the temperature and maintaining the humidity levels of the interior of the bus as defined in the following paragraphs.

HVAC equipped. See below for configuration.

The coach shall be equipped with a **Thermo King Coach Air Conditioning System**, with IntelligAir II controls with integrated diagnostics, or approved equals.

With the bus running at the design operating profile with corresponding door opening cycle, and carrying a number of passengers equal to 150 percent of the seated load, the HVAC system shall control the average passenger compartment temperature within arrange between 65 and 80 °F, while maintaining the relative humidity to a value of 50 percent or less. The system shall maintain these conditions while subjected to any outside ambient temperatures within arrange of 10 to 95 °F and at any ambient relative humidity levels between 5 and 50 percent.

When the bus is operated in outside ambient temperatures of 95 to 115 °F, the interior temperature of the bus shall be permitted to rise 0.5°F for each degree of exterior temperature in excess of 95 °F.

When the bus is operated in outside ambient temperatures in the range of -10 to 10 °F, the interior temperature of the bus shall not fall below 55 °F while the bus is running on the design operating profile.

System capacity testing, including pull-down/warm-up, stabilization and profile, shall be conducted in accordance to APTA's *Recommended Practice* "Transit Bus HVAC System Instrumentation and Performance Testing."

Additional testing shall be performed as necessary to ensure compliance to performance requirements stated herein.

### **Capacity and Performance Requirements**

The air-conditioning portion of the HVAC system shall be capable of reducing the passenger compartment temperature from 115 to 95 °F in less than 20 minutes after engine start-up. Engine temperature shall be within the normal operating range at the time of start-up of the cool-down test, and the engine speed shall be limited to fast idle, which may be activated by a driver-controlled device. During the cool-down period, the refrigerant pressure shall not exceed safe high-side pressures, and the condenser discharge air temperature, measured 6 in. from the surface of the coil, shall be less than 45 °F above the condenser inlet air temperature. The appropriate solar load as recommended in the APTA “Recommended Instrumentation and Performance Testing for Transit Bus Air Conditioning System,” representing 4 p.m. on August 21, shall be used. There shall be no passengers on board, and the doors and windows shall be closed.

#### **R134a**

The air conditioning system shall meet these performance requirements using R134a.

### **TS 55. Controls and Temperature Uniformity**

The HVAC system excluding the driver’s heater/defroster shall be centrally controlled with an advanced electronic/diagnostic control system with provisions for extracting/reading data. The system shall be compliant with J1939 Communication Protocol for receiving and broadcasting of data.

The operator shall have full control over the defroster and operator's heater. The operator shall be able to adjust the temperature in the operator's area through air distribution and fans. The interior climate control system shall switch automatically to the ventilating mode if the refrigerant compressor or condenser fan fails.

Interior temperature distribution shall be uniform to the extent practicable to prevent hot and/or cold spots. After stabilization with doors closed, the temperatures between any two points in the passenger compartment in the same vertical plane, and 6 inches to 72 inches above the floor, shall not vary by more than 5°F with doors closed. The interior temperatures, measured at the same height above the floor, shall not vary more than ± 5°F, from the front to the rear, from the average temperature determined in accordance to APTA Recommended Instrumentation and Performance Testing for Transit Bus Air Conditioning System. Variations of greater than ± 5°F will be allowed for limited, localized areas provided the majority of the measured temperatures fall within the specified requirement.

#### **TS 55.1 Auxiliary Heater**

No auxiliary heater.

### **TS 56. Air Flow**

#### **TS 56.1 Passenger Area**

The cooling mode of the interior climate control system shall introduce air into the bus at or near the ceiling height at a minimum rate of 25 cubic feet per minute (cfm) per passenger based on the standard configuration bus carrying a number of passengers equal to 150 percent of the seated load. Airflow shall be evenly distributed throughout the bus with air velocity not exceeding 100 feet per minute on any passenger. The ventilating mode shall provide air at a minimum flow rate of 20 cfm per passenger.

Airflow may be reduced to 15 cfm per passenger (150 percent of seated load) when operating in the heating mode. The fans shall not activate until the heating element has warmed sufficiently to assure at least 70°F air

outlet temperature. The heating air outlet temperature shall not exceed 120°F under any normal operating conditions.

### **TS 56.2 Driver's Area**

The bus interior climate control system shall deliver at least 100 cfm of air to the operator's area when operating in the ventilating and cooling modes. Adjustable nozzles shall permit variable distribution or shutdown of the airflow. Airflow in the heating mode shall be reduced proportionally to the reduction of airflow into the passenger area. The windshield defroster unit shall meet the requirements of SAE Recommended Practice J382, Windshield Defrosting Systems Performance Requirements, and shall have the capability of diverting heated air to the operator's feet and legs. The defroster or interior climate control system shall maintain visibility through the operator's side window.

### **TS 56.3 Controls for the Climate Control System (CCS)**

The controls for the operator's compartment for heating, ventilation, and cooling systems shall be integrated and shall meet the following requirements.

- (1) The heat/defrost system shall be controlled by a separate switch that has an "Off" position and *at least two positions for speed control*. All switches and controls shall preclude the possibility of clothing becoming entangled. An "On-Off" switch shall be located to the right of or near the main Defroster switch.
- (2) A manually operated control valve shall not be required since the electric heater will not use heated water.

### **TS 56.4 Driver's Compartment Requirements**

A separate heating, ventilation, and defroster system for the operator's area shall be provided and shall be controlled by the operator. The system shall meet the following requirements:

- (1) The heater and defroster system shall provide heating for the operator and heated air to completely defrost and defog the windshield, operator's side window, and the front door glasses in all operating conditions. Fan(s) shall be able to draw air from the bus body interior and pass it through the defroster system and to the operator's area. A minimum capacity of 100cfm shall be provided. The operator shall have complete control of the heat for their area.
- (2) The defroster supply outlets shall be located at the lower edge of the windshield. These outlets shall be durable and shall be free of sharp edges that can catch clothes during normal daily cleaning. The system shall be such that foreign objects such as coins or tickets cannot fall into the defroster air outlets. Adjustable ball vents shall be provided at the left of the operator's position to allow direction of air onto the side windows.

A ventilation system shall be provided, which can be integrated as part of the defroster system, to ensure operator comfort and shall be capable of providing fresh air in the foot and/or head areas. Vents shall be controllable by the operator from the normal driving position. Decals shall be provided indicating "operating instructions" and "open" and "closed" positions as well. When closed, vents shall be sealed to prevent the migration of water or air into the bus.

### **TS 56.5 Driver's Cooling**

The requirements for operator's cooling shall be consistent with specifications noted in section TS 52. There shall be no dedicated evaporator for drivers cooling.

## **TS 57. Air Filtration**

Air shall be filtered before entering the AC system and being discharged into the passenger compartment. The filter shall meet the ANSI/ASHRAE 52.1 requirement for 5 percent or better atmospheric dust spot efficiency, 50 percent weight arrestance, and a minimum dust holding capacity of 120 g per 1000 cfm cell. Air filters shall be easily removable for service and cleanable.

## **TS 58. Roof Ventilators**

For the 40-foot bus, two roof ventilators shall be provided in the roof of the bus, one approximately over or just forward of the front axle and the other, approximately over the rear axle.

Each ventilator shall be easily opened and closed manually by a 50<sup>th</sup> percentile female. If roof ventilator(s) cannot be reached by a 50<sup>th</sup> percentile female, then a tool shall be provided to allow this. When open with the bus in motion, this ventilator shall provide fresh air inside the bus. Ventilator shall cover an opening area no less than 425 square inches and shall be capable of being positioned as a scoop with either the leading or trailing edge open no less than 4 inches, or with all four edges raised simultaneously to a height of no less than 3-1/2 inches. An escape hatch shall be incorporated into the roof ventilator. Roof ventilator(s) shall be sealed to prevent entry of water when closed. A bilingual (English/Spanish) decal giving operating instructions shall be affixed to the interior of the hatch and emergency instructions for opening from the exterior shall be affixed to the outside of the hatch.

## **TS 59. Maintainability**

Manually controlled shut-off valves in the refrigerant lines shall allow isolation of the compressor and dehydrator filter for service. To the extent practicable, self-sealing couplings utilizing O-ring seals shall be used to break and seal the refrigerant lines during removal of major components, such as the refrigerant compressor. Shut-off valves may be provided in lieu of self-sealing couplings. The condenser shall be located to efficiently transfer heat to the atmosphere and shall not ingest air warmed above the ambient temperature by the bus mechanical equipment, or to discharge air into any other system of the bus. The location of the condenser shall preclude its obstruction by wheel splash, road dirt or debris. HVAC components located within 6 in. of floor level shall be constructed to resist damage and corrosion.

High and low refrigerant pressure electronic gauges to be located in the return air area.

## **TS 60. Entrance/Exit Area Heating**

No requirements for entrance/exit area heating.

## **TS 61. Floor-Level Heating**

### **TS 61.1 Transit Coach**

No requirements for floor-level heating.

## **EXTERIOR PANELS, FINISHES AND EXTERIOR LIGHTING**

### **TS 62. Design**

The bus shall have a clean, smooth, simple design, primarily derived from bus performance requirements and passenger service criteria. The exterior and body features, including grilles and louvers, shall be shaped to facilitate cleaning by automatic bus washers without snagging washer brushes. Water and dirt shall not be retained in or on any body feature to freeze or bleed out onto the bus after leaving the washer. The body and

windows shall be sealed to prevent leaking of air, dust or water under normal operating conditions and during cleaning in automatic bus washers for the service life of the bus.

Exterior panels shall be sufficiently stiff to minimize vibration, drumming or flexing while the bus is in service. When panels are lapped, the upper and forward panels shall act as a watershed. However, if entry of moisture into the interior of the vehicle is prevented by other means, then rear cap panels may be lapped otherwise. The windows, hatches and doors shall be able to be sealed. Accumulation of spray and splash generated by the bus's wheels shall be minimized on windows and mirrors.

### **TS 62.1 Materials**

Body materials shall be selected and the body fabricated to reduce maintenance, extend durability and provide consistency of appearance throughout the service life of the bus. Detailing shall be kept simple, and add-on devices and trim are minimized and integrated into the basic design.

### **TS 63. Pedestrian Safety**

Exterior protrusions along the side and front of the bus greater than ½ in. and within 80 in. of the ground shall have a radius no less than the amount of the protrusion. The exterior rearview mirrors, cameras and required lights and reflectors are exempt from the protrusion requirement. Advertising frames shall protrude no more than 7/8 in. from the body surface. Grilles, doors, bumpers and other features on the sides and rear of the bus shall be designed to minimize toeholds or handholds.

Exterior protrusions shall not cause a line-of-sight blockage for the driver.

### **TS 64. Repair and Replacement**

#### **TS 64.1 Side Body Panels**

The lower side body of the bus shall be easily repairable by either applying common composite body repair techniques or by having lower side body panels that are made of impact-resistant material and easily and quickly replaceable.

### **TS 65. Rain Gutters**

Rain gutters shall either be provided or designed as an integral part of the bus body. The rain gutters shall prevent water flowing from the roof onto the passenger doors, operator's side window, and exterior mirrors. When the bus is decelerated, the gutters shall not drain onto the windshield, or operator's side window, or into the door boarding area. Cross sections of the gutters shall be adequate for proper operation.

### **TS 66. License Plate Provisions**

Provisions shall be made to mount standard-size U.S./Canada license plates per SAE J686 on the front and rear of the bus. These provisions shall direct-mount or recess the license plates so that they can be cleaned by automatic bus-washing equipment without being caught by the brushes. The rear license plate provision shall be illuminated per SAE J587.

#### **TS 66.1 Rub rails**

No requirement for rub rails.

## **TS 67. Fender Skirts**

Features to minimize water spray from the bus in wet conditions shall be included in wheel housing design. Any fender skirts shall be easily replaceable. They shall be flexible if they extend beyond the allowable body width. Wheels and tires shall be removable with the fender skirts in place.

### **TS 67.1 Splash Aprons**

#### **Standard Splash Aprons**

Splash aprons, composed of ¼ in. minimum composition or rubberized fabric, shall be installed behind and/or in front of wheels as needed to reduce road splash and protect underfloor components. The splash aprons shall extend downward to within 6 in. off the road surface at static conditions. Apron widths shall be no less than tire widths. Splash aprons shall be bolted to the bus understructure. Splash aprons and their attachments shall be inherently weaker than the structure to which they are attached. The flexible portions of the splash aprons shall not be included in the road clearance measurements. Splash apron shall be installed as necessary to protect the wheelchair loading device from road splash.

## **TS 68. Service Compartments and Access Doors**

### **TS 68.1 Access Doors**

Access doors larger than 100 sq in. in area shall be equipped with corrosion-resistant flush-mounted latches or locks except for coolant and fuel fill access doors. All such access doors that require a tool to open shall be standardized throughout the vehicle and will require a nominal 5/16 in. square male tool to open or lock.

## **TS 69. Bumpers**

### **TS 69.1 Location**

Bumpers shall provide impact protection for the front and rear of the bus with the top of the bumper being 27 in., ±2 in., above the ground. Bumper height shall be such that when one bus is parked behind another, a portion of the bumper faces will contact each other.

### **TS 69.2 Front Bumper**

No part of the bus, including the bumper, shall be damaged as a result of a 5mph impact of the bus at curb weight with a fixed, flat barrier perpendicular to the bus's longitudinal centerline. The bumper shall return to its pre-impact shape within 10 minutes of the impact. The bumper shall protect the bus from damage as a result of 6.5 mph impacts at any point by the common carriage with contoured impact surface defined in Figure 2 of FMVSS 301 loaded to 4000lbs parallel to the longitudinal centerline of the bus. It shall protect the bus from damage as a result of 5.5mph impacts into the corners at a 30deg angle to the longitudinal centerline of the bus. The energy absorption system of the bumper shall be independent of every power system of the bus and shall not require service or maintenance in normal operation during the service life of the bus. The bumper may increase the overall bus length specified by no more than 7 in.

#### **Bike Rack**

A 3 position bike rack with deployment sensor shall be incorporated on the front bumper. Example Sportsworks Apex 3.

### **TS 69.3 Rear Bumper**

No part of the bus, including the bumper, shall be damaged as a result of a 2mph impact with a fixed, flat barrier perpendicular to the longitudinal centerline of the bus. The bumper shall return to its pre-impact shape within 10 minutes of the impact. When using a yard tug with a smooth, flat plate bumper 2 ft wide contacting the horizontal centerline of the rear bumper, the bumper shall provide protection at speeds up to 5 mph, over



pavement discontinuities up to 1 in. high, and at accelerations up to 2 mph/sec. The rear bumper shall protect the bus when impacted anywhere along its width by the common carriage with contoured impact surface defined in Figure 2 of FMVSS 301 loaded to 4000 lbs, at 4 mph parallel to or up to a 30degangle to the longitudinal centerline of the bus. The rear bumper shall be shaped to preclude unauthorized riders standing on the bumper. The bumper shall not require service or maintenance in normal operation during the service life of the bus. The bumper may increase the overall bus length specified by no more than 7 in.

## **TS 69.4 Bumper Material**

Bumper material shall be corrosion-resistant and withstand repeated impacts of the specified loads without sustaining damage. These bumper qualities shall be sustained throughout the service life of the bus.

## **TS 70. Finish and Color**

### **TS 70.1 Appearance**

All exterior surfaces shall be smooth and free of wrinkles and dents. Exterior surfaces to be painted shall be properly prepared as required by the paint system Supplier prior to application of paint to ensure a proper bond between the basic surface and successive coats of original paint for the service life of the bus. Drilled holes and cutouts in exterior surfaces shall be made prior to cleaning, priming and painting, where possible, to prevent corrosion. The bus shall be painted prior to installation of exterior lights, windows, mirrors and other items that are applied to the exterior of the bus. Body filler materials may be used for surface dressing, but not for repair of damaged or improperly fitted panels.

Paint shall be applied smoothly and evenly with the finished surface free of visible dirt and the following other imperfections:

- blisters or bubbles appearing in the topcoat film
- chips, scratches or gouges of the surface finish
- cracks in the paint film
- craters where paint failed to cover due to surface contamination
- overspray
- peeling
- runs or sags from excessive flow and failure to adhere uniformly to the surface
- chemical stains and water spots
- dry patches due to incorrect mixing of paint activators
- buffing swirls

Proper adhesion between the basic surface and successive coats of the original paint shall be measured using an Elcometer adhesion tester as outlined in ASTM D4541-85. Adhesion shall be a minimum 300 ft-lbs. The bus manufacturer shall supply test samples of the exterior surface for each step of the painting process that may be subject to adhesion testing per ASTM G4541-87 and ASTM D4145-85. ASTM D4541-93 may be used for inspection testing during assembly of the vehicle.

Standard Contractor exterior paint finish quality. Base bus gel coat in white.

## **TS 71. Decals, Numbering and Signing**

Monograms, numbers and other special signing may be applied to the inside and outside of the bus as required. Signs shall be durable and fade-, chip- and peel-resistant. They may be painted signs, decals or pressure-sensitive appliqué. All decals shall be installed per the decal Supplier recommendations. Signs shall be provided in compliance with the ADA requirements defined in 49 CFR Part 38, Subpart B, 38.27.

## **TS 71.1 Passenger Information**

ADA priority seating signs as required and defined by 49 CFR, Part 38.27 shall be provided to identify the seats designated for passengers with disabilities.

Requirements for a public information system in accordance with 49 CFR, Part 38.35 shall be provided.

## **TS 72. Exterior Lighting**

Exterior lighting and reflectors shall comply, as applicable, with Part 393, Subpart B of the FMCSA and FMVSS 108.

All exterior lights shall be designed to prevent entry and accumulation of moisture or dust. Commercially available LED-type lamps shall be utilized at all exterior lamp locations. Lamps, lenses and fixtures shall be interchangeable to the extent practicable. Light lenses shall be designed and located to prevent damage when running the vehicle through an automatic bus washer. Front marker (clearance) lights along with lights located on the roof and sides of the bus shall have protective shields or be of the flush mount type to protect the lens against minor impacts.

### **Standard Lamps**

All LED lamps shall be standard installation of the OEM. The entire assembly shall be specifically coated to protect the light from chemical and abrasion degradation.

### **Standard Size**

Size of LED lamps used for tail, brake and turn signal lamps shall be standard installation of OEM.

## **TS 72.1 Backup Light/Alarm**

Visible and audible warnings shall inform following vehicles or pedestrians of reverse operation. Visible reverse operation warning shall conform to SAE Standard J593. Audible reverse operation warning shall conform to SAE Recommended Practice J994 Type C or D.

## **TS 72.2 Doorway Lighting**

Lamps at the front and rear passenger doorways (if applicable) shall comply with ADA requirements and shall activate only when the doors open. These lamps shall illuminate the street surface to a level of no less than 1 foot-candle for a distance of 3 ft outward from the outboard edge of the door threshold. The lights may be positioned above or below the lower daylight opening of the windows and shall be shielded to protect passengers' eyes from glare.

## **TS 72.3 Turn Signals**

### **Standard Turn Signals**

Turn-signal lights shall be provided on the front, rear, curb and street sides of the bus in accordance with federal regulations.

## **TS 72.4 Headlights**

Standard OEM headlight installation shall be provided in accordance with FMVSS 108 and Part 393, Subpart B of the FMCSA as applicable.

## **TS 72.5 Brake Lights**

### **TS 72.5.1 Transit Coach**

Brake lights shall be provided in accordance with FMVSS 108 and Part 393, Subpart B of the FMCSA as applicable. A center mounted brake light is provided.

### **TS 72.6 Service Area Lighting (Interior and Exterior)**

LED lamps are provided in the motor compartment and communication box to generally illuminate the area for night emergency repairs or adjustments. The passenger door operator compartments and junction/apparatus panels shall have adequate light to illuminate the space of the service areas to levels needed to complete typical emergency repairs and adjustments. The service area lamps shall be suitable for the environment in which they are mounted.

Motor compartment lamps shall be controlled by a switch mounted in the motor compartment. All other service area lamps shall be controlled by switches mounted on or convenient to the lamp assemblies. Power to the service area lighting shall be programmable. Power shall latch on with activation of the switch and shall be automatically discontinued (timed out) after 30 minutes to prevent damage caused by inadvertently leaving the service area lighting switch in the “on” position after repairs are made.

## **INTERIOR PANELS AND FINISHES**

### **TS 73. General Requirements**

Materials shall be selected on the basis of maintenance, durability, appearance, safety, flammability, and tactile qualities. Materials shall be strong enough to resist everyday abuse and be vandalism and corrosion resistant. Trim and attachment details shall be kept simple and unobtrusive. Interior trim shall be secured to avoid resonant vibrations under normal operational conditions.

Interior surfaces more than 10 in. below the lower edge of the side windows or windshield shall be shaped so that objects placed on them fall to the floor when the coach is parked on a level surface. Any components and other electrical components within close proximity to these surfaces shall also be resistant to this cleaning method.

### **TS 74. Interior Panels**

Panels shall be easily replaceable and tamper-resistant. They shall be reinforced, as necessary, to resist vandalism and other rigors of transit bus service. Individual trim panels and parts shall be interchangeable to the extent practicable.

#### **TS 74.1 Driver Area Barrier**

A barrier or bulkhead between the driver and the street-side front passenger seat shall be provided. The barrier shall minimize glare and reflections in the windshield directly in front of the barrier from interior lighting during night operation. The driver’s barrier shall extend from the top of the wheel well to the ceiling the level of the seated driver and shall fit close to the bus side windows and wall to prevent passengers from reaching the driver or the driver’s personal effects.

#### **TS 74.2 Modesty Panels**

Sturdy divider panels constructed of durable, unpainted, corrosion-resistant material complementing the interior shall be provided to act as both a physical and visual barrier for seated passengers.

Design and installation of modesty panels located in front of forward-facing seats shall include a handhold or grab handle along its top edge. These dividers shall be mounted on the sidewall and shall project toward the aisle no farther than passenger knee projection in longitudinal seats or the aisle side of the transverse seats. Modesty panels shall extend from at least the window opening of the side windows, and those forward of transverse seats shall extend downward to 1 and 1½ in. above the floor. Panels forward of longitudinal seats shall extend to below the level of the seat cushion. Dividers positioned at the doorways shall provide no less than a 2½ in. clearance between the modesty panel and a fully open, inward opening door, or the path of a deploying flip-out ramp to protect passengers from being pinched. Modesty panels installed at doorways shall be equipped with grab rails if passengers assist are not provided by other means.

The modesty panel and its mounting shall withstand a static force of 250 lbs applied to a 4 × 4 in. area in the center of the panel without permanent visible deformation.

Modesty panels shall be installed as stated.

### **TS 74.3 Front End**

The entire front end of the bus shall be sealed to prevent debris accumulation behind the dash and to prevent the driver's feet from kicking or fouling wiring and other equipment. The front end shall be free of protrusions that are hazardous to passengers standing at the front of the standee line area of the bus during rapid decelerations. Paneling across the front of the bus and any trim around the driver's compartment shall be formed metal or composite material. Composite dash panels shall be reinforced as necessary, vandal-resistant and replaceable. All colored, painted and plated parts forward of the driver's barrier shall be finished with a surface that reduces glare. Any mounted equipment must have provision to support the weight of equipment.

### **TS 74.4 Rear Bulkhead**

The rear bulkhead and rear interior surfaces shall be material suitable for exterior skin; painted and finished to exterior quality; or paneled with melamine-type material, composite, scratch-resistant plastic or carpeting and trimmed with stainless steel, aluminum or composite.

The rear bulkhead paneling shall be contoured to fit the ceiling, side walls and seat backs so that any litter or trash will tend to fall to the floor or seating surface when the bus is on a level surface. Any air vents in this area shall be louvered to reduce airflow noise and to reduce the probability of trash or liter being thrown or drawn through the grille. If it is necessary to remove the panel to service components located on the rear bulkhead, the panel shall be hinged or shall be able to be easily removed and replaced. Grilles where access to or adjustment of equipment is required shall be heavy-duty and designed to minimize damage and limit unauthorized access

### **TS 74.5 Headlining**

Ceiling panels shall be made of durable, corrosion resistant, easily cleanable material. Headlining shall be supported to prevent buckling, drumming or flexing and shall be secured without loose edges. Headlining materials shall be treated or insulated to prevent marks due to condensation where panels are in contact with metal members. Moldings and trim strips, as required to make the edges tamperproof, shall be stainless steel, aluminum or plastic, colored to complement the ceiling material. Headlining panels covering operational equipment that is mounted above the ceiling shall be on hinges for ease of service but retained to prevent inadvertent opening.

## TS 74.6 Fastening

Interior panels shall be attached so that there are no exposed unfinished or rough edges or rough surfaces. Fasteners should be corrosion resistant. Panels and fasteners shall not be easily removable by passengers. Exposed interior fasteners should be minimized, and where required shall be tamper-resistant.

## TS 74.7 Insulation

Any insulation material used between the inner and outer panels shall minimize the entry and/or retention of moisture. Insulation properties shall be unimpaired during the service life of the bus. Any insulation material used inside the engine compartment shall not absorb or retain oils or water and shall be designed to prevent casual damage that may occur during maintenance operations.

The combination of inner and outer panels on the sides, roof, wheel wells and ends of the bus, and any material used between these panels, shall provide a thermal insulation sufficient to meet the interior temperature requirements. The bus body shall be thoroughly sealed so that the driver or passengers cannot feel drafts during normal operations with the passenger doors closed.

## TS 74.8 Floor Covering

The floor covering shall have a non-skid walking surface that remains effective in all weather conditions. The floor covering, as well as transitions of flooring material to the main floor and to the entrance and exit area, shall be smooth and present no tripping hazards. Seams shall be sealed/welded per manufacturer's specifications. The standee line shall be approximately 2 in. wide and shall extend across the bus aisle. The color and pattern shall be consistent throughout the floor covering.

The area of the front ramp platform as well as the floor area under and around the ramp in the vestibule area may be LineX sprayed-on polyurethane, non-skid surface. The step edge shall be LineX yellow.

Any areas on floor, which are not intended for standees, such as areas "swept" during passenger door operation, shall be clearly and permanently marked. The floor in the operator's compartment shall be easily cleaned and shall be arranged to minimize debris accumulation.

A one-piece 3/16<sup>th</sup> inch minimum thickness center strip shall extend from the vertical wall of the rear settee between the aisle sides of transverse seats to the standee line. If the floor is of a bi-level construction, then center strip shall be one-piece at each level. The covering between the center strip and the wheel housings may be separate pieces, but be 1/8<sup>th</sup> inch minimum thickness smooth finish to top of cove with 1 to 2 inch radius. Exceptions allowed for the 1 to 2 inch radius on welded joint floor systems only. At the rear door, however, a separate strip as wide as the door shall extend from the center strip to the outboard edge of the rear/exit area.

The floor under the seats shall be covered with smooth surface flooring material. The floor covering shall closely fit the sidewall cove or extend to the top of the cove. **Preferred flooring is Altro Transflor Figura – Pinwheel TFFG20005F-2705F or approved equal.**

## TS 74.9 Interior Lighting

The light source shall be located to minimize windshield glare, with distribution of the light focused primarily on the passengers' reading plane while casting sufficient light onto the advertising display. The lighting system may be designed to form part of or the entire air distribution duct.

The lens material shall be translucent polycarbonate. Lenses shall be designed to effectively "mask" the light source. Lenses shall be sealed to inhibit incursion of dust and insects yet be easily removable for service.

Access panels shall be provided to allow servicing of components located behind light panels. If necessary, the entire light fixture shall be hinged.

## **TS 74.10 Passenger**

### **First Row Lights**

The operator shall be able to select either dim, off or bright for interior lighting. When in “day run” mode, all interior lights shall be as selected by the driver. In “night run” mode, the front most lights on each side (behind the driver and the front door) shall be turned on only when either door is opened. With both doors closed, the front most lights shall be off to minimize light reflection and glare on the windshield. The rear lights shall be on in the setting selected by the driver (off, dim or bright).

All interior lighting shall be turned off whenever the transmission selector is in reverse. The interior lights shall be LED. Agency shall approve all lighting diagrams.

### **First Light Modules Dim/Extinguish When Front Door is Closed**

When the master switch is in the “run” or “night/run” mode, the first light module on each side of the coach shall automatically extinguish or dim when the front door is in the closed position and illuminate when the door is opened.

## **TS 74.11 Driver’s Area**

The driver’s area shall have a light to provide general illumination, and it shall illuminate the half of the steering wheel nearest the driver to a level of 5 to 10 foot-candles.

## **TS 74.12 Seating Areas**

The interior lighting system shall provide a minimum 15 foot-candle illumination on a 1 sq ft plane at an angle of 45 degrees from horizontal, centered 33 in. above the floor and 24 in. in front of the seat back at each seat position. Allowable average light level for the rear bench seats shall be 7 foot-candles.

## **TS 74.13 Vestibules/Doors**

Floor surface in the aisles shall be a minimum of 10 foot-candles, and the vestibule area a minimum of 4 foot-candles with the front doors open and a minimum of 2 foot-candles with the front doors closed. The front entrance area and curb lights shall illuminate when the front door is open and master run switch is in the “lights” positions. Rear exit area and curb lights shall illuminate when the rear door is unlocked.

## **TS 74.14 Step Lighting**

Step lighting for the intermediate steps between lower and upper floor levels shall be a minimum of 4 foot-candles and shall illuminate in all engine run positions. The step lighting shall be low-profile to minimize tripping and snagging hazards for passengers and shall be shielded as necessary to protect passengers’ eyes from glare.

## **TS 74.15 Ramp Lighting**

Exterior and interior ramp lighting shall comply with CFR Part 49, Sections 19.29 and 19.31.

## **TS 74.16 Turntable Lighting**

Lighting in the turntable can be reduced to 7 foot-candles.

## **TS 74.17 Farebox Lighting**

Sufficient farebox lighting shall be provided and automatically come on whenever the front doors are opened and the run switch is in the “night run” or “night park” position

## **TS 75. Fare Collection**

Provide all wiring and structural provisions for installation of fare collection devices. Location of the fare collection device shall not restrict traffic in the vestibule, including wheelchairs if a front door loading device is used, and shall allow the driver to easily reach the farebox controls and to view the fare register. The fare box shall not restrict access to the driver area, shall not restrict operation of driver controls and shall not — either by itself or in combination with stanchions, transfer mounting, cutting and punching equipment, or route destination signs — restrict the driver’s field of view per SAE Recommended Practice J1050. The location and mounting of the fare collection device shall allow use, without restriction, by passengers. The fare box location shall permit accessibility to the vault for easy manual removal or attachment of suction devices. Meters and counters on the fare box shall be readable on a daily basis. The floor under the fare box shall be reinforced as necessary to provide a sturdy mounting platform and to prevent shaking of the fare box.

Transfer mounting, cutting and punching equipment (if required) shall be located in a position convenient to the driver.

Contractor shall provide fare collection installation layout to the Agency for approval.

**Optional: Agency will provide farebox to Contractor for install. – Genfare Fastfare**

## **TS 76. Interior Access Panels and Doors**

Access for maintenance and replacement of equipment shall be provided by panels and doors that appear to be an integral part of the interior. Access doors shall be hinged with gas props or over-center springs, where practical, to hold the doors out of the mechanic’s way. Panels shall prevent entry of mechanism lubricant into the bus interior. All fasteners that retain access panels shall be captive in the cover.

### **TS 76.1 Floor Panels**

Access openings in the floor shall be sealed to prevent entry of fumes and water into the bus interior. Flooring material at or around access openings shall be flush with the floor and shall be edge-bound with stainless steel or another material that is acceptable to the Agency to prevent the edges from coming loose. Access openings shall be asymmetrical so that reinstalled flooring shall be properly aligned. Fasteners shall tighten flush with the floor.

The number of special fastener tools required for panel and access door fasteners shall be minimized.

## **PASSENGER ACCOMMODATIONS**

### **TS 77. Passenger Seating**

#### **TS 77.1 Arrangements and Seat Style**

The passenger seating arrangement in the bus shall be such that seating capacity is maximized and in compliance to the following requirements.

##### **Forward-Facing Seat Configuration**

Passenger seats shall be arranged in a transverse, forward-facing configuration, except at the wheel housings and turntable, if applicable, where aisle-facing seats may be arranged as appropriate with due regard for

passenger access and comfort. Other areas where aisle-facing seats may be provided are at wheelchair securement areas and platforms (such as for fuel tank storage space).

### **TS 77.2 Rearward Facing Seats**

Rearward facing seats not allowed.

### **TS 77.3 Padded Inserts/Cushioned Seats**

The passenger seats shall be equipped with non-padded inserts throughout the bus.

### **TS 77.4 Seat back fitness**

#### **Back insert Seat Configuration**

The seat back insert thickness shall not exceed 1in. in the knee room area.

### **TS 77.5 Drain Hole in Seats**

No requirements for drain hole provision in seat inserts.

### **TS 77.6 Hip-to-Knee Room**

Hip-to-knee room measured from the center of the seating position, from the front of one seat back horizontally across the highest part of the seat to vertical surface immediately in front, shall be a minimum of 26 in. At all seating positions in paired transverse seats immediately behind other seating positions, hip-to-knee room shall be no less than 27 in.

### **TS 77.7 Foot Room**

Foot room, measured at the floor forward from a point vertically below the front of the seat cushion, shall be no less than 14 in. Seats immediately behind the wheel housings and modesty panels may have foot room reduced.

### **TS 77.8 Aisles**

The aisle between the seats shall be no less than 20 in. wide at seated passenger hip height. Seat backs shall be shaped to increase this dimension to no less than 24 in. at 32 in. above the floor (standing passenger hip height).



## TS 77.9 Dimensions

**FIGURE 6**  
Seating Dimensions and Standard Configuration

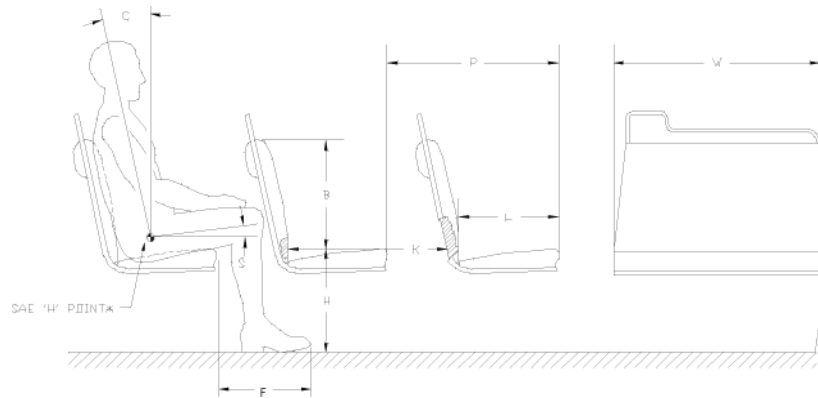

Seat dimensions for the various seating arrangements shall have the dimensions as follows (refer to **Figure 6**):

- The width, W, of the two-passenger transverse seat shall be a minimum 35 in.
- The length, L, shall be 17 in.,  $\pm 1$  in.
- The seat back height, B, shall be a minimum of 15 in.
- The seat height, H, shall be 17 in.,  $\pm 1$  in. For the rear lounge (or settee) and longitudinal seats, and seats located above raised areas for storage of under-floor components, a cushion height of up to 18 in.,  $\pm 2$  in., will be allowed. This shall also be allowed for limited transverse seats, but only with the expressed approval of the Agency.
- Foot room = F.
- The seat cushion slope, S, shall be between 5 and 11 degrees.
- The seat back slope, C, shall be between 8 and 17 degrees.
- Hip to knee room = K.
- The pitch, P, is shown as reference only.

## TS 77.10 Structure and Design

The passenger seat frame and its supporting structure shall be constructed and mounted so that space under the seat is maximized and is completely free of obstructions to facilitate cleaning.

Seats, structures and restraints around the securement area should not infringe into the mobility device envelope or maneuverability.

The transverse seat structure shall be fully cantilevered from the sidewall with sufficient strength for the intended service. The lowest part of the seat assembly that is within 12 in. of the aisle shall be at least 10 in. above the floor.

In locations at which cantilevered installation is precluded by design and/or structure, other seat mounting may be allowed.

All transverse objects — including seat backs, modesty panels, and longitudinal seats — in front of forward-facing seats shall not impart a compressive load in excess of 1000 lbs onto the femur of passengers ranging in size from a 5th-percentile female to a 95th-percentile male during a 10g deceleration of the bus. This deceleration shall peak at 0.05 to 0.015 seconds from initiation. Permanent deformation of the seat resulting

from two 95th-percentile males striking the seat back during this 10g deceleration shall not exceed 2 in., measured at the aisle side of the seat frame at height H. The seat back should not deflect more than 14 in., measured at the top of the seat back, in a controlled manner to minimize passenger injury. Structural failure of any part of the seat or sidewall shall not introduce a laceration hazard.

The seat assembly shall withstand static vertical forces of 500 lbs applied to the top of the seat cushion in each seating position with less than ¼-in. permanent deformation in the seat or its mountings. The seat assembly shall withstand static horizontal forces of 500 lbs evenly distributed along the top of the seat back with less than ¼-in. permanent deformation in the seat or its mountings. The seat backs at the aisle position and at the window position shall withstand repeated impacts of two 40-lb sandbags without visible deterioration. One sandbag shall strike the front 40,000 times and the other sandbag shall strike the rear 40,000 times. Each sandbag shall be suspended on a 36-in. pendulum and shall strike the seat back 10,000 times each from distances of 6, 8, 10 and 12 in. Seats at both seating positions shall withstand 4000 vertical drops of a 40-lb sandbag without visible deterioration. The sandbag shall be dropped 1000 times each from heights of 6, 8, 10 and 12 in. Seat cushions shall withstand 100,000 randomly positioned 3½-in. drops of a squirting, 150-lb, smooth-surfaced, buttocks-shaped striker with only minimal wear on the seat covering and no failures to seat structure or cushion suspension components.

The back of each transverse seat shall incorporate a handhold no less than 7/8 in. in diameter for standees and seat access/egress. The handhold shall not be a safety hazard during severe decelerations. The handhold shall extend above the seat back near the aisle so that standees shall have a convenient vertical assist, no less than 4 in. long that may be grasped with the full hand. This handhold shall not cause a standee using this assist to interfere with a seated 50th-percentile male passenger. The handhold shall also be usable by a 5th-percentile female, as well as by larger passengers, to assist with seat access/egress for either transverse seating position. The upper rear portion of the seat back and the seat back handhold immediately forward of transverse seats shall be padded and/or constructed of energy absorbing materials. During a 10g deceleration of the bus, the HIC number (as defined by SAE Standard J211a) shall not exceed 400 for passengers ranging in size from a 5th percentile female through a 95th percentile male.

The seat back handhold may be deleted from seats that do not have another transverse seat directly behind and where a vertical assist is provided.

Longitudinal seats shall be the same general design as transverse seats but without seat back handholds. Longitudinal seats may be mounted on the wheelhouses. Armrests shall be included on the ends of each set of longitudinal seats except on the forward end of a seat set that is immediately to the rear of a transverse seat, the driver's barrier, or a modesty panel, when these fixtures perform the function of restraining passengers from sliding forward off the seat. Armrests are not required on longitudinal seats located in the wheelchair parking area that fold up when the armrest on the adjacent fixed longitudinal seat is within 3½ in. of the end of the seat cushion. Armrests shall be located from 7 to 9 in. above the seat cushion surface. The area between the armrest and the seat cushion shall be closed by a barrier or panel. The top and sides of the armrests shall have a minimum width of 1 in. and shall be free from sharp protrusions that form a safety hazard.

Seat back handhold and armrests shall withstand static horizontal and vertical forces of 250 lbs applied anywhere along their length with less than ¼-in. permanent deformation. Seat back handhold and armrests shall withstand 25,000 impacts in each direction of a horizontal force of 125 lbs with less than ¼-in. permanent deformation and without visible deterioration.

## **TS 77.11 Construction and Materials**

Selected materials shall minimize damage from vandalism and shall reduce cleaning time. The seats shall be attached to the frame with tamper-resistant fasteners. Coloring shall be consistent throughout the seat

material, with no visually exposed portion painted. Any exposed metal touching the sides or the floor of the bus shall be stainless steel. The seat, pads and cushions shall be contoured for individuality, lateral support and maximum comfort and shall fit the framework to reduce exposed edges.

The minimum radius of any part of the seat back, handhold or modesty panel in the head or chest impact zone shall be a nominal ¼-in. The seat back and seat back handhold immediately forward of transverse seats shall be constructed of energy-absorbing materials to provide passenger protection and, in a severe crash, allow the passenger to deform the seating materials in the impact areas. Complete seat assemblies shall be interchangeable to the extent practicable.

**Agency to select seat fabric.**

## **TS 78. Passenger Assists**

Passenger assists in the form of full grip, vertical stanchions or handholds shall be provided for the safety of standees and for ingress/egress. Passenger assists shall be convenient in location, shape, and size for both the 95th-percentile male and the 5th-percentile female standee. Starting from the entrance door and moving anywhere in the bus and out the exit door, a vertical assist shall be provided either as the vertical portion of seat back assist or as a separate item so that a 5th-percentile female passenger may easily move from one assist to another using one hand and the other without losing support. All handholds and stanchions at front doorway, around farebox, and at interior steps for bi-level designs shall be powder-coated in a high-contrast yellow color. The forward-most vertical stanchions on either side of the aisle immediately behind the driver's area shall be:

The forward-most vertical stanchions on either side of the aisle immediately behind the driver's area shall be powder-coated yellow.

### **TS 78.1 Assists**

Excluding those mounted on the seats and doors, the assists shall have a cross-sectional diameter between 1¼ and 1½ in. or shall provide an equivalent gripping surface with no corner radii less than ¼ in. All passenger assists shall permit a full hand grip with no less than 1½ in. of knuckle clearance around the assist. Passenger assists shall be designed to minimize catching or snagging of clothes or personal items and shall be capable of passing the NHTSA Drawstring Test.

Any joints in the assist structure shall be underneath supporting brackets and securely clamped to prevent passengers from moving or twisting the assists. Seat handholds may be of the same construction and finish as the seat frame. Door mounted passenger assists shall be of anodized aluminum, stainless steel or powder-coated metal. Connecting tees and angles may be powder-coated metal castings. Assists shall withstand a force of 300 lbs applied over a 12-in. lineal dimension in any direction normal to the assist without permanent visible deformation. All passenger assist components, including brackets, clamps, screw heads and other fasteners used on the passenger assists shall be designed to eliminate pinching, snagging and cutting hazards and shall be free from burrs or rough edges.

### **TS 78.2 Front Doorway**

Front doors, or the entry area, shall be fitted with ADA-compliant assists. Assists shall be as far outward as practicable, but shall be located no farther inboard than 6 in. from the outside edge of the entrance step and shall be easily grasped by a 5th-percentile female boarding from street level. Door assists shall be functionally continuous with the horizontal front passenger assist and the vertical assist and the assists on the wheel housing or on the front modesty panel.

### **TS 78.3 Vestibule**

The aisle side of the driver's barrier, the wheel housings, and when applicable the modesty panels shall be fitted with vertical passenger assists that are functionally continuous with the overhead assist and that extend to within 36 in. of the floor. These assists shall have sufficient clearance from the barrier to prevent inadvertent wedging of a passenger's arm.

A horizontal passenger assist shall be located across the front of the bus and shall prevent passengers from sustaining injuries on the fare collection device or windshield in the event of a sudden deceleration. Without restricting the vestibule space, the assist shall provide support for a boarding passenger from the front door through the fare collection procedure. The assist shall be no less than 36 in. above the floor. The assists at the front of the bus shall be arranged to permit a 5th-percentile female passenger to easily reach from the door assist, to the front assist, to vertical assists on the driver's barrier, wheel housings or front modesty panel.

### **TS 78.4 Rear Doorway(s)**

Vertical assists that are functionally continuous with the overhead assist shall be provided at the aisle side of the transverse seat immediately forward of the rear door and on the aisle side of the rear door modesty panel(s). Passenger assists shall be provided on modesty panels that are functionally continuous with the rear door assists. Rear doors, or the exit area, shall be fitted with assists having a cross-sectional diameter between 1¼ and 1½ in. or providing an equivalent gripping surface with no corner radii less than ¼ in., and shall provide at least 1½ in. of knuckle clearance between the assists and their mounting. The assists shall be designed to permit a 5th-percentile female to easily move from one assist to another during the entire exiting process. The assists shall be located no farther inboard than 6 in. from the outside edge of the rear doorway step.

### **TS 78.5 Overhead**

Except forward of the standee line and at the rear door, a continuous, full grip, overhead assist shall be provided. This assist shall be located over the center of the aisle seating position of the transverse seats. The assist shall be no less than 70 in. above the floor.

Grab straps or other extensions as necessary shall be provided for sections where vertical assists are not available and for the use by passengers that cannot reach to 70 in.

Grab straps shall be: Extruded grey nylon

Overhead assists shall simultaneously support 150 lbs on any 12-in. length. No more than 5 percent of the full grip feature shall be lost due to assist supports.

### **TS 78.6 Longitudinal Seat Assists**

Longitudinal seats shall have vertical assists located between every other designated seating position, except for seats that fold/flip up to accommodate wheelchair securement. Assists shall extend from near the leading edge of the seat and shall be functionally continuous with the overhead assist. Assists shall be staggered across the aisle from each other where practicable and shall be no more than 52 in. apart or functionally continuous for a 5th percentile female passenger.

### **TS 78.7 Wheel Housing Barriers/Assists**

Unless passenger seating is provided on top of wheel housing, passenger assists shall be mounted around the exposed sides of the wheel housings (and propulsion compartments if applicable), which shall also be designed to prevent passengers from sitting on wheel housings. Such passenger assists shall also effectively retain items, such as bags and luggage, placed on top of wheel housing.

## **TS 79. Passenger Doors**

### **TS 79.1 Transit Coach**

#### **TS 79.1.1 Front door**

Forward of the front wheels and under direct observation of the driver.

### **TS 79.2 Materials and Construction**

Structure of the doors, their attachments, inside and outside trim panels and any mechanism exposed to the elements shall be corrosion resistant. Door panel construction shall be of corrosion-resistant metal or reinforced non-metallic composite materials. When fully opened, the doors shall provide a firm support and shall not be damaged if used as an assist by passengers during ingress or egress. Door edges shall be sealed to prevent infiltration of exterior moisture, noise, dirt and air elements from entering the passenger compartment, to the maximum extent possible based on door types.

The closing edge of each door panel shall have no less than 2 in. of soft weather stripping. The doors, when closed, shall be effectively sealed, and the hard surfaces of the doors shall be at least 4 in. apart (not applicable to single doors). The combined weather seal and window glazing elements of the front door shall not exceed 10 deg of binocular obstruction of the driver's view through the closed door..

### **TS 79.3 Door Glazing**

The front and rear doors shall both have full length glazing that is bonded to the frame.

### **TS 79.4 Door Projection**

#### **TS 79.4.1 Exterior**

The exterior projection of the front doors beyond the side of the bus shall be minimized and shall not block the line of sight of the rear exit door via the curb side mirror when the doors are fully open. The exterior projection of both doors shall be minimized and shall not exceed 14 in. during the opening or closing cycles or when doors are fully opened.

#### **TS 79.4.2 Interior**

Projection inside the bus shall not cause an obstruction of the rear door mirror or cause a hazard for standees.

### **TS 79.5 Door Height Above Pavement**

It shall be possible to open and close either passenger door when the bus loaded to gross vehicle weight rating is not knelt and parked with the tires touching an 8-in.-high curb on a street sloping toward the curb so that the street side wheels are 5 in. higher than the right side wheels.

### **TS 79.6 Closing Force**

Closing door edge speed shall not exceed 12 in. per second, and opening door speed shall not exceed 19 in. per second. Power doors shall not slam closed under any circumstance, even if the door is obstructed during the closing cycle. If a door is obstructed during the closing cycle, the pressure exerted on the obstruction shall not increase once initial contact has been made.

Power-close rear doors shall be equipped with an obstruction sensing system such that if an obstruction is within the path of the closing doors, the doors will stop and/or reverse direction prior to imparting a 10-lb force on 1 sq in. of that obstruction. If a contactless obstruction sensing system is employed, it shall be capable of discriminating between the normal doorway environment and passengers or other obstructions within the doorway, and of altering the zones of detection based upon the operating state of the door system.

Doors closed by a return spring or counterweight-type device shall be equipped with an obstruction-sensing device that, at a minimum, alerts the driver if an obstruction is detected between the closing doors. Doors closed by a return spring or counterweight type device, when unlocked, shall be capable of being pushed to the point where the door starts to open with a force not to exceed 25 lbs applied to the center edge of the forward door panel.

Whether or not the obstruction sensing system is present or functional, it shall be possible to withdraw a 1½ in. diameter cylinder from between the center edges of a closed and locked door with an outward force not greater than 42 lbs.

### **TS 79.6.1 Rear Door Closing Force**

Power-close rear doors shall be equipped with an obstruction-sensing system such that if an obstruction is within the path of the closing doors, the doors will stop and/or reverse direction prior to imparting a 10-lb force on 1 sq in. of that obstruction. If a contactless obstruction sensing system is employed, it shall be capable of discriminating between the normal doorway environment and passengers or other obstructions within the doorway, and of altering the zones of detection based upon the operating state of the door system.

### **TS 79.7 Actuators**

Doors shall open or close completely in not more than 3.5 seconds from the time of control actuation and shall be subject to the closing force requirements.

Door actuators shall be adjustable so that the door opening and closing speeds can be independently adjustable to satisfy the above requirements. Actuators and the complex door mechanism shall be concealed from passengers but shall be easily accessible for servicing. The door actuators shall be rebuildable. If powered by compressed air, exhaust from the door system shall be routed below the floor of the bus to prevent accumulation of any oil that may be present in the air system and to muffle sound.

Door actuators and associated linkages shall maximize door holding forces in the fully open and fully closed positions to provide firm, non-rattling, non-fluttering door panels while minimizing the force exerted by the doors on an obstruction midway between the fully open and closed positions.

The rear door actuator(s) shall be under the complete control of the vehicle operator and shall open and close in response to the position of the driver's door control.

Doors that employ a "swing" or pantograph geometry and/or are closed by a return spring or counterweight-type device shall be equipped with a positive mechanical holding device that automatically engages and prevents the actuation mechanism from being back-driven from the fully closed position. The holding device shall be overcome only when the driver's door control is moved to an "Exit Door Enable" position and the vehicle is moving at a speed of less than 2 mph, or in the event of actuation of the emergency door release.

Locked doors shall require a force of more than 300 lbs to open manually. When the locked doors are manually forced to open, damage shall be limited to the bending of minor door linkage with no resulting damage to the doors, actuators or complex mechanism.

### **TS 79.7.1 Rear Door Interlocks (Transit Coach)**

See "Hardware Mounting" for door system interlock requirements.

## **TS 79.8 Emergency Operation**

In the event of an emergency, it shall be possible to manually open doors designated as emergency exits from inside the bus using a force of no more than 25 lbs after actuating an unlocking device. The unlocking device shall be clearly marked as an emergency-only device and shall require two distinct actions to actuate. The respective door emergency unlocking device shall be accessible from the doorway area. The unlocking device shall be easily reset by the operator without special tools or opening the door mechanism enclosure. Doors that are required to be classified as “Emergency Exits” shall meet the requirements of FMVSS 217.

## **TS 79.9 Door Control**

The door control shall be located in the operator’s area within the hand reach envelope described in SAE Recommended Practice J287, “Driver Hand Control Reach.” The driver’s door control shall provide tactile feedback to indicate commanded door position and resist inadvertent door actuation.

## **TS 79.10 Door Controller**

Doors shall be operated by push-button controls, conveniently located and operable within the driver’s reach. The push buttons shall be labeled.

## **TS 79.11 Door Open/Close**

### **Operator-Controlled Front and Passenger-Controlled Rear Doors**

Operation of, and power to, the front passenger doors shall be completely controlled by the operator. Power to rear doors shall be controlled by operator. After enabling, the rear doors shall be opened by the passenger

A control or valve in the operator’s compartment shall shut off the power to, and/or dump the power from, the front door mechanism to permit manual operation of the front door with the bus shut down. A master door switch, which is not within reach of the seated operator, when set in the “off” position shall close the rear/center doors, deactivate the door control system, release the interlocks, and permit only manual operation of the rear/center doors.

## **TS 80. Accessibility Provisions**

Space and body structural provisions shall be provided at the front door of the bus to accommodate a wheelchair loading system.

### **TS 80.1 Loading Systems**

A self-contained fold-out type wheelchair ramp system, compliant with requirements defined in most recent revision of 49 CFR Part 38, Subpart B, §38.23c, shall be provided.

### **TS 80.2 Lift**

An automatically-controlled, power-operated ramp system compliant to requirements defined in 49 CFR Part 38, Subpart B, §38.23c shall provide ingress and egress quickly, safely and comfortably, both in forward and rearward directions, for a passenger in a wheelchair from a level street or curb.

The wheelchair loading system shall be located at the front door, with the ramp being of a simple hinged, flip-out type design being capable of deploying to the ground at a maximum 6:1 slope. The wheelchair lift control system must be capable of receiving multiplex command from vehicle interlocks.

When the system is not in use, the passageway shall appear normal. In the stored position of the ramp, no tripping hazards shall be present, and any resulting gaps shall be minimized. The controls shall be simple to operate with no complex phasing operations required, and the loading system operation shall be under the surveillance and complete control of the driver. The bus shall be prevented from moving during the loading or unloading cycle by a throttle and brake interlock system. The loading system shall be inhibited from stowing/deploying when a passenger is on the ramp/platform. A passenger departing or boarding via the ramp shall be able to easily obtain support by grasping the passenger assist located on the doors or other assists provided for this purpose. The platform shall be designed to protect the ramp from damage and persons on the sidewalk from injury during the extension/retraction or lowering/raising phases of operation.

### **TS 80.3 Wheelchair Accommodations**

#### **Two Forward-Facing Wheelchair Securement Locations**

Two forward-facing locations, as close to the wheelchair loading system as practical, shall provide parking space and securement system compliant with ADA requirements for a passenger in a wheelchair. QStraint Q'Pod system is preferred for wheelchair securement.

### **TS 80.4 Interior Circulation**

Maneuvering room inside the bus shall accommodate easy travel for a passenger in a wheelchair from the loading device and from the designated securement area. It shall be designed so that no portion of the wheelchair protrudes into the aisle of the bus when parked in the designated parking space(s). When the positions are fully utilized, an aisle space of no less than 20 in. shall be maintained. As a guide, no width dimension should be less than 34 in. Areas requiring 90-degree turns of wheelchairs should have a clearance arc dimension no less than 45 in., and in the parking area where 180-degree turns are expected, space should be clear in a full 60-in.-diameter circle. A vertical clearance of 12 in. above the floor surface should be provided on the outside of turning areas for wheelchair footrest.

## **SIGNAGE AND COMMUNICATION**

### **TS 81. Destination Signs (LED)**

A destination sign system shall be furnished on the front, right side near the front door, and on the rear of the vehicle. All signs shall be controlled via a single human-machine interface (HMI). In the absence of a single mobile data terminal (MDT), the HMI shall be conveniently located for the bus driver within reach of the seated driver. Preferred is White LED Hanover destination signs or approved equal.

The driver shall be able to access the sign while seated.

The destination sign compartments shall meet the following minimum requirements:

- Compartments shall be designed to prevent condensation and entry of moisture and dirt.
- Compartments shall be designed to prevent fogging of both compartment window and glazing on the unit itself.
- Access shall be provided to allow cleaning of inside compartment window and unit glazing.

### **TS 82. Passenger Information and Advertising**

#### **TS 82.1 Interior Displays**

Provisions shall be made on the rear of the driver's barrier or equipment box located on the wheel well for a frame to retain information such as routes and schedules. Customer shall review locations and options after award.



Advertising media 11 in. high and 0.09 in. thick shall be retained near the juncture of the bus ceiling and sidewall. The retainers may be concave and shall support the media without adhesives. The media shall be illuminated by the interior light system.

## **TS 82.2 Exterior Displays**

Provisions can be made to integrate advertising, which may be specified by the customer, into the exterior design of the bus.

## **TS 83. Passenger Stop Request/Exit Signal**

A passenger "Stop Requested" signal system that complies with applicable ADA requirements defined in 49 CFR, Part 38.37 shall be provided. The system shall consist of a touch tape, chime, and interior sign message. The touch tape shall be accessible to all seated passengers, with provisions for standees. It shall be easily accessible to all passengers, seated or standing. Vertical touch tape shall be provided at each window mulion and adjacent to each wheelchair parking position and priority seating positions.

A heavy-duty "stop requested" signal button shall be installed on modesty panel stanchion immediately forward of the rear door and clearly identified as "STOP."

A single "stop requested" chime shall sound when the system is first activated. A double chime shall sound anytime the system is activated from wheelchair passenger areas.

Exit signals located in the wheelchair passenger area shall be no higher than 4 feet above the floor. Instructions shall be provided to clearly indicate function and operation of these signals.

### **TS 83.1 Signal Chime**

A single "stop requested" chime shall sound when the system is first activated. A double chime shall sound anytime the system is activated from wheelchair passenger areas.

Exit signals located in the wheelchair passenger area shall be no higher than 4 feet above the floor. Instructions shall be provided to clearly indicate function and operation of these signals.

## **TS 84. Communications**

### **TS 84.1 Camera Surveillance System**

Provide all wiring and mounting locations for a multi-camera surveillance system including the installation of cameras, recorder, microphone, etc.. Current standard is AngelTrax - 9 camera system.

### **TS 84.2 Public Address System**

A public address system shall be provided on each bus for facilitating radio system and driver-originated announcements to passengers.

### **TS 84.3 Automatic Passenger Counter (APC)**

An infrared APC system shall be installed. Agency to provide details of APC system, including installation locations and number of buses to be equipped. System shall be Hella APC or approved equal.

## **TS 84.4 Radio Handset and Control System**

### **TS 84.4.1 Drivers Speaker**

Each bus shall have a recessed speaker in the ceiling panel above the driver. This speaker shall be the same component used for the speakers in the passenger compartment. It shall have 8 Ohms of impedance.

### **TS 84.4.2 Handset**

Contractor will install a handset for driver use. Current provider is Motorola.

### **TS 84.4.3 Driver Display Unit (DDU)**

Contractor shall install a driver display unit as close to the driver's instrument panel as possible.

### **TS 84.4.4 Emergency Alarm**

Contractor shall install an emergency alarm that is accessible to the driver but hidden from view.

## **TS 85. Event Data Recorders (EDR)**

No EDR shall be installed.

## **TS 86. Vehicle Charging Requirements**

### **TS 86.1 Plug-In Charging**

#### **TS 86.1.1 Charging Requirements**

The vehicle shall be able to charge with a commercially available plug-in charger that uses the North American automotive standard for DC plug-in charging, SAE J1772 CCS Type 1 standard charging protocol. There shall be a minimum of one (2) charge receptacle on the bus located at the rear, curb-side of the vehicle and rear, street side .

#### **TS 86.1.2 Plug-In Charger Requirements**

The plug-in charger(s) must comply with SAE J1772 CCS Type 1 standard for plug-in charging. The charger(s) must be able to charge the vehicle from 0% State of Charge to 100% State of Charge in under seven (7) hours.

### **TS 86.2 On-Route Charging**

#### **TS 86.2.1 Coach Charging Requirements**

The coach must be able to charge on-route using a charger that complies with SAE J3105 Electric Vehicle Power Transfer System Using a Mechanized Couple, the standard for on-route conductive charging.

#### **TS 86.2.2 On-Route Charger Requirements**

The on-route charging system must comply with SAE J3105 *Electric Vehicle Power Transfer System Using a Mechanized Couple*, the standard for on-route conductive charging. The on-route charging system shall be able charge the coach's energy storage system at rates up to 350kW.

## **TS 87. Approved Equals**

**Table 8** lists products that have been approved for the bus procurement. The list contains products that are of interest to the Agency and is not intended to be a comprehensive listing of every product required for the manufacture of the subject buses. Product categories not listed are left to the discretion of the Contractor so long as the product complies with the specifications. Product specification information is for reference only and may not reflect the latest or future improvements by manufacturers. Any change, revision or substitution

of specified products requires approval .of the agency. To add to or revise this list, Contractor must submit a written request per the Specification by the due date found in the RFP for approved equals.

**TABLE 8**  
Approved Equals Products

<b>Product</b>	<b>Manufacturer</b>	<b>Product Specification</b>

## **SECTION 7: WARRANTY REQUIREMENTS**

### **WR 1. Basic Provisions**

#### **WR 1.1 Warranty Requirements**

##### **WR 1.1.1 Contractor Warranty**

Warranties in this document are in addition to any statutory remedies or warranties imposed on the Contractor. Consistent with this requirement, the Contractor warrants and guarantees to the original Agency each complete bus and specific subsystems and components as follows. Performance requirements based on design criteria shall not be deemed a warranty item.

##### **WR 1.1.2 Complete Bus**

The complete bus, propulsion system, components, major subsystems and body and chassis structure are warranted to be free from Defects and Related Defects for one year or 50,000 miles, whichever comes first, beginning on the date of revenue service but not longer than 15 days after acceptance under “Inspection, Testing and Acceptance.” The warranty is based on regular operation of the bus under the operating conditions prevailing in the Agency’s locale.

##### **WR 1.1.3 Body and Chassis Structure**

Body, body structure, structural elements of the suspension and engine cradle are warranted to be free from Defects and Related Defects for three years or 150,000 miles, whichever comes first.

Primary load-carrying members of the bus structure, including structural elements of the suspension, are warranted against corrosion failure and/or Fatigue Failure sufficient to cause a Class 1 or Class 2 Failure for a period of 12 years or 500,000 miles, whichever comes first.

##### **WR 1.1.4 Propulsion System**

Propulsion system components, including the traction motor(s), traction motor controller(s), transmission, drive motors, drive and non-drive axles, and any other propulsion system-related line replacement components, shall be warranted to be free from Defects and Related Defects for the standard 12 years or 500,000 miles, whichever comes first. The propulsion system manufacturer’s standard warranty, delineating items excluded from the Extended Warranty, should be submitted in accordance with the Request for Pre-Offer Change or Approved Equal or with the Form for Proposal Deviation.

### **WR 1.1.5 Energy Storage System**

The Energy Storage System (ESS) shall be leased. The Energy Storage System (ESS), including the traction battery, Battery Management System, and any other ESS-related line replacement component, shall be warranted to be free from Defects and Related Defects for the term of the ESS lease. The ESS shall also be warranted for the term of the lease to remain within Warrantable End Of Life. The ESS original specified energy storage capacity and Warrantable End of Life, as a percentage of the original specified energy capacity, shall be clearly defined by the Proposer. Acceptable methods for measuring or obtaining ESS storage capacity with respect to its original specified capacity shall be clearly identified by the manufacturer. The manufacturer will propose the test method, and certify the results are true and accurate. The test will be performed according to a documented test procedure. The Agency is allowed to engage third-parties for capacity testing. If applicable, the proposal shall include a comprehensive statement of any additional warranty terms relating to the ESS, including explanation of all disclaimers within the warranty.

### **WR 1.1.6 Emission Control System (ECS)**

The Contractor warrants the emission control system for five years or 100,000 miles, whichever comes first. The ECS shall include, but is not limited to, the following components:

- complete exhaust system, including catalytic converter (if required)
- after treatment device
- components identified as emission control devices

### **WR 1.1.7 Subsystems**

The following subsystems shall be warranted to be free from Defects and Related Defects for two years or 100,000 miles, whichever comes first:

- Brake system: Foundation brake components, including advancing mechanisms, as supplied with the axles, excluding friction surfaces
- Destination signs: All destination sign equipment for the front, side and rear signs, power modules and operator control
- Heating, ventilating: Roof and/or rear main unit only, excluding floor heaters and front defroster
- AC unit and compressor: Roof and/or rear main unit only, excluding floor heaters and front defroster
- Door systems: Door operating actuators and linkages
- Air compressor
- Air dryer
- Wheelchair lift and ramp system: Lift and/or ramp parts and mechanical only
- Starter
- Alternator: Alternator only; does not include the drive system.
- Charge air cooler: Charge air cooler including core, tanks and including related surrounding framework and fittings
- Fire suppression: Fire suppression system including tank and extinguishing agent dispensing system
- Hydraulic systems: Including radiator fan drive and power steering as applicable
- Propulsion system cooling systems: Radiator including core, tanks and related framework, including surge tank and transmission cooler
- Power electronics: DC/DC converters, inverters, if supplied
- Passenger seating excluding upholstery
- Fuel storage and delivery system
- Surveillance system including cameras and video recorders

The following subsystems shall be warranted to be free from Defects and Related Defects for 12 years or 500,000 miles, whichever comes first:

- Low-voltage and high-voltage electrical wiring and harnesses (12 years)

#### **WR 1.1.8 Serial Numbers**

Upon delivery of each bus, the Contractor shall provide a complete electronic list of serialized units installed on each bus to facilitate warranty tracking. If supplied with the bus, the list shall include but is not limited to the following:

- Engine or traction motor(s) (if applicable)
- Propulsion system controller/inverter(s)
- Energy storage pack(s) or module(s)
- Power electronics: DC/DC converters, inverters
- Transmission
- Alternator
- Starter
- HVAC system and major components
- Drive axle
- Power steering unit
- Fuel cylinders (if applicable)
- Air compressor
- Wheelchair ramp (if applicable)

The Contractor shall provide updated serial numbers resulting from warranty campaigns. The format of the list shall be approved by the Agency prior to delivery of the first production bus.

#### **WR 1.1.9 Extension of Warranty**

If, during the warranty period, repairs or modifications on any bus are made necessary by defective design, materials or workmanship but are not completed due to lack of material or inability to provide the proper repair for thirty (30) calendar days, then the applicable warranty period shall be extended by the number of days equal to the delay period.

#### **WR 1.2 Voiding of Warranty**

The warranty shall not apply to the failure of any part or component of the bus that directly results from misuse, negligence, accident or repairs not conducted in accordance with the Contractor-provided maintenance manuals and with workmanship performed by adequately trained personnel in accordance with recognized standards of the industry. The warranty also shall be void if the Agency fails to conduct normal inspections and scheduled preventive maintenance procedures as recommended in the Contractor's maintenance manuals and if that omission caused the part or component failure. The Agency shall maintain documentation, auditable by the Contractor, verifying service activities in conformance with the Contractor's maintenance manuals.

#### **WR 1.3 Exceptions and Additions to Warranty**

The warranty shall not apply to the following items:

- scheduled maintenance items
- normal wear-out items
- items furnished by the Agency

Should the Agency require the use of a specific product and has rejected the Contractor's request for an alternate product, then the standard Supplier warranty for that product shall be the only warranty provided to the Agency. This product will not be eligible under "Fleet Defects," below.

The Contractor shall not be required to provide warranty information for any warranty that is less than or equal to the warranty periods listed.

### **WR 1.3.1 Pass-Through Warranty**

Should the Contractor elect to not administer warranty claims on certain components and wish to transfer this responsibility to the sub-suppliers, or to others, the Contractor shall request this waiver.

Contractor shall state in writing that the Agency's warranty reimbursements will not be impacted. The Contractor also shall state in writing any exceptions and reimbursement including all costs incurred in transport of vehicles and/or components. At any time during the warranty period, the Contractor may request approval from the Agency to assign its warranty obligations to others, but only on a case-by-case basis approved in writing by the Agency. Otherwise, the Contractor shall be solely responsible for the administration of the warranty as specified. Warranty administration by others does not eliminate the warranty liability and responsibility of the Contractor.

### **WR 1.3.2 Superior Warranty**

The Contractor shall pass on to the Agency any warranty offered by a component Supplier that is superior to that required herein. The Contractor shall provide a list to the Agency noting the conditions and limitations of the Superior Warranty not later than the start of production. The Superior Warranty shall not be administered by the Contractor.

## **WR 1.4 Fleet Defects**

### **WR 1.4.1 Occurrence and Remedy**

A Fleet Defect is defined as cumulative failures of twenty-five (25) percent of the same components in the same or similar application in a minimum fleet size of twelve (12) or more buses where such items are covered by warranty. A Fleet Defect shall apply only to the base warranty period in sections entitled "Complete Bus," "Propulsion System" and "Major Subsystems." When a Fleet Defect is declared, the remaining warranty on that item/component stops. The warranty period does not restart until the Fleet Defect is corrected.

For the purpose of Fleet Defects, each option order shall be treated as a separate bus fleet. In addition, should there be a change in a major component within either the base order or an option order, the buses containing the new major component shall become a separate bus fleet for the purposes of Fleet Defects.

The Contractor shall correct a Fleet Defect under the warranty provisions defined in "Repair Procedures." After correcting the Defect, the Agency and the Contractor shall mutually agree to and the Contractor shall promptly undertake and complete a work program reasonably designed to prevent the occurrence of the same Defect in all other buses and spare parts purchased under this Contract. Where the specific Defect can be solely attributed to particular identifiable part(s), the work program shall include redesign and/or replacement of only the defectively designed and/or manufactured part(s). In all other cases, the work program shall include inspection and/or correction of all the buses in the fleet via a mutually agreed-to arrangement. The Contractor shall update, as necessary, technical support information (parts, service and operator's manuals) due to changes resulting from warranty repairs. The Agency may immediately declare a Defect in design resulting in a safety hazard to be a Fleet Defect. The Contractor shall be responsible to furnish, install and replace all defective units.

### **WR 1.4.2 Exceptions to Fleet Defect Provisions**

The Fleet Defect warranty provisions shall not apply to Agency-supplied items, such as radios, fare collection equipment, communication systems and tires. In addition, Fleet Defects shall not apply to interior and exterior finishes, hoses, fittings and fabric.

## **WR 2. Repair Procedures**

### **WR 2.1 Repair Performance**

The Contractor is responsible for all warranty-covered repair Work. To the extent practicable, the Agency will allow the Contractor or its designated representative to perform such Work. At its discretion, the Agency may perform such Work if it determines it needs to do so based on transit service or other requirements. Such Work shall be reimbursed by the Contractor.

### **WR 2.2 Repairs by the Contractor**

If the Agency detects a Defect within the warranty periods defined in this section, it shall, within thirty (30) days, notify the Contractor's designated representative. The Contractor or its designated representative shall, if requested, begin Work on warranty-covered repairs within five calendar days after receiving notification of a Defect from the Agency. The Agency shall make the bus available to complete repairs timely with the Contractor's repair schedule.

The Contractor shall provide at its own expense all spare parts, tools and space required to complete repairs. At the Agency's option, the Contractor may be required to remove the bus from the Agency's property while repairs are being effected. If the bus is removed from the Agency's property, then repair procedures must be diligently pursued by the Contractor's representative.

### **WR 2.3 Repairs by the Agency**

#### **WR 2.3.1 Parts Used**

If the Agency performs the warranty-covered repairs, then it shall correct or repair the Defect and any Related Defects utilizing parts supplied by the Contractor specifically for this repair. At its discretion, the Agency may use Contractor-specified parts available from its own stock if deemed in its best interests.

#### **WR 2.3.2 Contractor-Supplied Parts**

The Agency may require that the Contractor supply parts for warranty-covered repairs being performed by the Agency. Those parts may be remanufactured but shall have the same form, fit and function, and warranty. The parts shall be shipped prepaid to the Agency from any source selected by the Contractor within fourteen (14) days of receipt of the request for said parts and shall not be subject to an Agency handling charge.

#### **WR 2.3.3 Defective Component Return**

The Contractor may request that parts covered by the warranty be returned to the manufacturing plant. The freight costs for this action shall be paid by the Contractor. Materials should be returned in accordance with the procedures outlined in "Warranty Processing Procedures."

#### **WR 2.3.4 Failure Analysis**

The Contractor shall, upon specific request of the Agency, provide a failure analysis of Fleet Defect or safety-related parts, or major components, removed from buses under the terms of the warranty that could affect fleet operation. Such reports shall be delivered within 60 days of the receipt of failed parts.



### **WR 2.3.5 Reimbursement for Labor and Other Related Costs**

The Agency shall be reimbursed by the Contractor for labor. The amount shall be determined by the Agency for a qualified mechanic at a straight time wage rate of [insert wage] per hour, which includes fringe benefits and overhead adjusted for the Agency's most recently published rate in effect at the time the Work is performed, plus the cost of towing the bus if such action was necessary and if the bus was in the normal service area. These wage and fringe benefit rates shall not exceed the rates in effect in the Agency's service garage at the time the Defect correction is made.

### **WR 2.3.6 Reimbursement for Parts**

The Agency shall be reimbursed by the Contractor for defective parts and for parts that must be replaced to correct the Defect. The reimbursement shall be at the current price at the time of repair and shall include taxes where applicable, plus fifteen (15) percent handling costs. Handling costs shall not be paid if parts are supplied by the Contractor and shipped to the Agency.

### **WR 2.3.7 Reimbursement Requirements**

The Contractor shall respond to the warranty claim with an accept/reject decision including necessary failure analysis no later than sixty (60) days after the Agency submits the claim and defective part(s), when requested. Reimbursement for all accepted claims shall occur no later than sixty (60) days from the date of acceptance of a valid claim. The Agency may dispute rejected claims or claims for which the Contractor did not reimburse the full amount. The parties agree to review disputed warranty claims during the following quarter to reach an equitable decision to permit the disputed claim to be resolved and closed. The parties also agree to review all claims at least once per quarter throughout the entire warranty period to ensure that open claims are being tracked and properly dispositioned.

### **WR 2.4 Warranty after Replacement/Repairs**

If any component, unit or subsystem is repaired, rebuilt or replaced by the Contractor or by the Agency with the concurrence of the Contractor, then the component, unit or subsystem shall have the unexpired warranty period of the original. Repairs shall not be warranted if Contractor-provided or authorized parts are not used for the repair, unless the Contractor has failed to respond within five days, in accordance with "Repairs by the Contractor."

If an item is declared to be a Fleet Defect, then the warranty stops with the declaration of the Fleet Defect. Once the Fleet Defect is corrected, the item(s) shall have three (3) months or remaining time and/or miles of the original warranty, whichever is greater. This remaining warranty period shall begin on the repair/replacement date for corrected items on each bus if the repairs are completed by the Contractor or on the date the Contractor provides all parts to the Agency.

### **WR 2.4.1 Warranty Processing Procedures**

The following list represents requirements by the Contractor to the Agency for processing warranty claims. One failure per bus per claim is allowed.

- bus number and VIN
- total vehicle life mileage at time of repair
- date of failure/repair
- acceptance/in-service date
- Contractor part number and description
- component serial number
- description of failure
- all costs associated with each failure/repair (invoices may be required for third-party costs):

- towing
- road calls
- labor
- materials
- parts
- handling
- troubleshooting time

### **WR 2.5 Forms**

The Agency's forms will be accepted by the Contractor if all of the above information is included. Electronic submittal may be used if available between the Contractor and the Agency.

### **WR 2.6 Return of Parts**

When returning defective parts to the Contractor, the Agency shall tag each part with the following:

- bus number and VIN
- claim number
- part number
- serial number (if available)

### **WR 2.7 Timeframe**

Each claim must be submitted no more than thirty (30) days from the date of failure and/or repair, whichever is later. All defective parts must be returned to the Contractor, when requested, no more than forty-five (45) days from the date of repair.

### **WR 2.8 Reimbursements**

Reimbursements are to be transmitted to the following address:

Warranty claims will be handled by our operator Transdev.

Transdev Services, Inc.  
3664 Leeds Ave.  
N. Charleston, SC 29405

## SECTION 8: QUALITY ASSURANCE

### QA 1. Contractor's In-Plant Quality Assurance Requirements

#### QA 1.1 Quality Assurance Organization

##### QA 1.1.1 Organization Establishment

The Contractor shall establish and maintain an effective in-plant quality assurance organization. It shall be a specifically defined organization and should be directly responsible to the Contractor's top management.

##### QA 1.1.2 Control

The quality assurance organization shall exercise quality control over all phases of production, from initiation of design through manufacture and preparation for delivery. The organization shall also control the quality of supplied articles.

##### QA 1.1.3 Authority and Responsibility

The quality assurance organization shall have the authority and responsibility for reliability, quality control, inspection planning, establishment of the quality control system, and acceptance/rejection of materials and manufactured articles in the production of the transit buses.

#### QA 1.2 Quality Assurance Organization Functions

##### QA 1.2.1 Minimum Functions

The quality assurance organization shall include the following minimum functions:

- **Work instructions:** The quality assurance organization shall verify inspection operation instructions to ascertain that the manufactured product meets all prescribed requirements.
- **Records maintenance:** The quality assurance organization shall maintain and use records and data essential to the effective operation of its program. These records and data shall be available for review by the resident inspectors. Inspection and test records for this procurement shall be available for a minimum of one year after inspections and tests are completed.
- **Corrective action:** The quality assurance organization shall detect and promptly ensure correction of any conditions that may result in the production of defective transit buses. These conditions may occur in designs, purchases, manufacture, tests or operations that culminate in defective supplies, services, facilities, technical data or standards.

##### QA 1.2.2 Basic Standards and Facilities

The following standards and facilities shall be basic in the quality assurance process:

- **Configuration control:** The Contractor shall maintain drawings, assembly procedures and other documentation that completely describe a qualified bus that meets all of the options and special requirements of this procurement. The quality assurance organization shall verify that each transit bus is manufactured in accordance with these controlled drawings, procedures and documentation.
- **Measuring and testing facilities:** The Contractor shall provide and maintain the necessary gauges and other measuring and testing devices for use by the quality assurance organization to verify that the buses conform to all specification requirements. These devices shall be calibrated at established periods against certified measurement standards that have known, valid relationships to national standards.
- **Production tooling as media of inspection:** When production jigs, fixtures, tooling masters, templates, patterns and other devices are used as media of inspection, they shall be proved for

accuracy at formally established intervals and adjusted, replaced or repaired as required to maintain quality.

- **Equipment use by resident inspectors:** The Contractor's gauges and other measuring and testing devices shall be made available for use by the resident inspectors to verify that the buses conform to all specification requirements. If necessary, the Contractor's personnel shall be made available to operate the devices and to verify their condition and accuracy.

### QA 1.2.3 Maintenance of Control

The Contractor shall maintain quality control of purchases:

- **Supplier control:** The Contractor shall require each Supplier to maintain a quality control program for the services and supplies that it provides. The Contractor's quality assurance organization shall inspect and test materials provided by Suppliers for conformance to specification requirements. Materials that have been inspected, tested and approved shall be identified as acceptable to the point of use in the manufacturing or assembly processes. Controls shall be established to prevent inadvertent use of nonconforming materials.
- **Purchasing data:** The Contractor shall verify that all applicable specification requirements are properly included or referenced in purchase orders of articles to be used on transit buses.

### QA 1.2.4 Manufacturing Control

- **Controlled conditions:** The Contractor shall ensure that all basic production operations, as well as all other processing and fabricating, are performed under controlled conditions. Establishment of these controlled conditions shall be based on the documented Work instructions, adequate production equipment and special working environments if necessary.
- **Completed items:** A system for final inspection and test of completed transit buses shall be provided by the quality assurance organization. It shall measure the overall quality of each completed bus.
- **Nonconforming materials:** The quality assurance organization shall monitor the Contractor's system for controlling nonconforming materials. The system shall include procedures for identification, segregation and disposition.
- **Statistical techniques:** Statistical analysis, tests and other quality control procedures may be used when appropriate in the quality assurance processes.
- **Inspection status:** A system shall be maintained by the quality assurance organization for identifying the inspection status of components and completed transit buses. Identification may include cards, tags or other normal quality control devices.

### QA 1.2.5 Inspection System

The quality assurance organization shall establish, maintain and periodically audit a fully documented inspection system. The system shall prescribe inspection and test of materials, Work in process and completed articles. As a minimum, it shall include the following controls:

- **Inspection personnel:** Sufficient trained inspectors shall be used to ensure that all materials, components and assemblies are inspected for conformance with the qualified bus design.
- **Inspection records:** Acceptance, rework or rejection identification shall be attached to inspected articles. Articles that have been accepted as a result of approved materials review actions shall be identified. Articles that have been reworked to specified drawing configurations shall not require special identification. Articles rejected as unsuitable or scrap shall be plainly marked and controlled to prevent installation on the bus. Articles that become obsolete as a result of engineering changes or other actions shall be controlled to prevent unauthorized assembly or installation. Unusable articles shall be isolated and then scrapped. Discrepancies noted by the Contractor or resident inspectors during assembly shall be entered by the inspection personnel on a record that accompanies the major

component, subassembly, assembly or bus from start of assembly through final inspection. Actions shall be taken to correct discrepancies or deficiencies in the manufacturing processes, procedures or other conditions that cause articles to be in nonconformity with the requirements of the Contract specifications. The inspection personnel shall verify the corrective actions and mark the discrepancy record. If discrepancies cannot be corrected by replacing the nonconforming materials, then the Agency shall approve the modification, repair or method of correction to the extent that the Contract specifications are affected.

- **Quality assurance audits:** The quality assurance organization shall establish and maintain a quality control audit program. Records of this program shall be subject to review by the Agency.

## **QA 2. Inspection**

### **QA 2.1 Inspection Stations**

Inspection stations shall be at the best locations to provide for the Work content and characteristics to be inspected. Stations shall provide the facilities and equipment to inspect structural, electrical, hydraulic and other components and assemblies for compliance with the design requirements.

Stations shall also be at the best locations to inspect or test characteristics before they are concealed by subsequent fabrication or assembly operations. These locations shall minimally include underbody structure completion, body framing completion, body prior to paint preparation, water test, propulsion system installation completion, underbody dress-up and completion, bus prior to final paint touchup, bus prior to road test, and bus final road test completion.

### **QA 2.2 Resident Inspectors**

#### **QA 2.2.1 Resident Inspector's Role**

The Agency shall be represented at the Contractor's plant by resident inspectors. Resident inspectors may be Agency employees or outside contractors. The Agency shall provide the identity of each inspector and shall also identify their level of authority in writing. They shall monitor, in the Contractor's plant, the manufacture of transit buses built under the procurement. The presence of these resident inspectors in the plant shall not relieve the Contractor of its responsibility to meet all of the requirements of this procurement. The Agency shall designate a primary resident inspector, whose duties and responsibilities are delineated in "Pre-Production Meetings," "Authority" and "Pre-Delivery Tests," below. Contractor and resident inspector relations shall be governed by the guidelines included as Attachment A to this section.

#### **QA 2.2.2 Pre-Production Meetings**

The primary resident inspector may participate in design review and Pre-Production Meetings with the Agency. At these meetings, the configuration of the buses and the manufacturing processes shall be finalized, and all Contract documentation provided to the inspector.

No less than thirty (30) days prior to the beginning of bus manufacture, the primary resident inspector may meet with the Contractor's quality assurance manager and may conduct a pre-production audit meeting. They shall review the inspection procedures and finalize inspection checklists. The resident inspectors may begin monitoring bus construction activities two weeks prior to the start of bus fabrication.

#### **QA 2.2.3 Authority**

Records and data maintained by the quality assurance organization shall be available for review by the resident inspectors. Inspection and test records for this procurement shall be available for a minimum of one year after inspections and tests are completed.

The Contractor's gauges and other measuring and testing devices shall be made available for use by the resident inspectors to verify that the buses conform to all specification requirements. If necessary, the Contractor's personnel shall be made available to operate the devices and to verify their condition and accuracy.

Discrepancies noted by the resident inspector during assembly shall be entered by the Contractor's inspection personnel on a record that accompanies the major component, subassembly, assembly or bus from start of assembly through final inspection. Actions shall be taken to correct discrepancies or deficiencies in the manufacturing processes, procedures or other conditions that cause articles to be in nonconformity with the requirements of the Contract specifications. The inspection personnel shall verify the corrective actions and mark the discrepancy record. If discrepancies cannot be corrected by replacing the nonconforming materials, then the Agency shall approve the modification, repair or method of correction to the extent that the Contract specifications are affected.

The primary resident inspector shall remain in the Contractor's plant for the duration of bus assembly Work under this Contract. Only the primary resident inspector or designee shall be authorized to release the buses for delivery. The resident inspectors shall be authorized to approve the pre-delivery acceptance tests. Upon request to the quality assurance supervisors, the resident inspectors shall have access to the Contractor's quality assurance files related to this procurement. These files shall include drawings, assembly procedures, material standards, parts lists, inspection processing and reports, and records of Defects.

#### **QA 2.2.4 Support Provisions**

The Contractor shall provide office space for the resident inspectors in close proximity to the final assembly area. This office space shall be equipped with desks, outside and interplant telephones, Internet access, file cabinet and chairs.

#### **QA 2.2.5 Compliance with Safety Requirements**

At the time of the Pre-Production Meeting, the Contractor shall provide all safety and other operational restrictions that govern the Contractor's facilities. These issues will be discussed and the parties will agree which rules/restrictions will govern the Agency's inspector(s) and any other Agency representatives during the course of the Contract.

### **QA 3. Acceptance Tests**

#### **QA 3.1 Responsibility**

Fully documented tests shall be conducted on each production bus following manufacture to determine its acceptance to the Agency. These acceptance tests shall include pre-delivery inspections and testing by the Contractor and inspections and testing by the Agency after the buses have been delivered.

#### **QA 3.2 Pre-Delivery Tests**

The Contractor shall conduct acceptance tests at its plant on each bus following completion of manufacture and before delivery to the Agency. These pre-delivery tests shall include visual and measured inspections, as well as testing the total bus operation and, if electric drive, charging operation. The tests shall be conducted and documented in accordance with written test plans approved by the Agency.

Additional tests may be conducted at the Contractor's discretion to ensure that the completed buses have attained the required quality and have met the requirements in "Section 6: Technical Specifications." The Agency may, prior to commencement of production, demand that the Contractor demonstrate compliance with any requirement in that section if there is evidence that prior tests have been invalidated by the Contractor's change of Supplier or change in manufacturing process. Such demonstration shall be by actual

test, or by supplying a report of a previously performed test on similar or like components and configuration. Any additional testing shall be recorded on appropriate test forms provided by the Contractor and shall be conducted before acceptance of the bus.

The pre-delivery tests shall be scheduled and conducted with thirty (30) days' notice so that they may be witnessed by the resident inspectors, who may accept or reject the results of the tests. The results of pre-delivery tests, and any other tests, shall be filed with the assembly inspection records for each bus. The underfloor equipment shall be available for inspection by the resident inspectors, using a pit or bus hoist provided by the Contractor. A hoist, scaffold or elevated platform shall be provided by the Contractor to easily and safely inspect bus roofs. Delivery of each bus shall require written authorization of the primary resident inspector. Authorization forms for the release of each bus for delivery shall be provided by the Contractor. An executed copy of the authorization shall accompany the delivery of each bus.

### **QA 3.2.1 Visual and Measured Inspections**

Visual and measured inspections shall be conducted with the bus in a static condition. The purpose of the inspection testing includes verification of overall dimension and weight requirements, that required components are included and are ready for operation, and that components and subsystems designed to operate with the bus in a static condition do function as designed.

### **QA 3.2.2 Total Bus Operation**

Total bus operation shall be evaluated during road tests. The purpose of the road tests is to observe and verify the operation of the bus as a system and to verify the functional operation of the subsystems that can be operated only while the bus is in motion.

Each bus shall be driven for a minimum of fifteen (15) miles during the road tests. If requested, computerized diagnostic printouts or electronic files showing the performance of each bus shall be produced and provided to the Agency. Observed Defects shall be recorded on the test forms. The bus shall be retested when Defects are corrected and adjustments are made. This process shall continue until Defects or required adjustments are no longer detected.

## Attachment A: New Bus Manufacturing Inspection Guidelines

### Pre-Production Meeting

#### Responsibilities

##### Agency

##### Agency

- Provides conformed copy of technical requirements.
- Recommended staff to be involved may include the following:
  - Project manager
  - Technical engineer
  - Contract administrator
  - Quality assurance administrator
  - Warranty administrator
- Process for inspector's role (to deal with Agency) for negotiated changes after freeze date.
- Contractual requirements:
  - Milestones
  - Documentation
  - Title requirements
  - Deliverables
  - Payments
  - Reliability tracking

##### Manufacturer

- Identifies any open issues.
- Recommended staff to be involved may include the following:
  - Project manager
  - Technical engineer(s)
  - Contract administrator
  - Quality assurance administrator
  - Warranty administrator
- Production flow (buses/week, shifts).
- Delivery schedule and offsite component build-up schedule.
- Bus QA documentation (including supplier application approvals and/or any certifications required for the specific production).
- Communication flow/decision making.

##### Inspector

- Agree on decisions inspectors can and cannot make.
- Primary contact for problems, etc.
- Production flow process (description of manufacturing by station).
- Factory hours (manage inspection schedule based on production hours).
- Plant rules.
- Safety requirements.
- Orientation requirements.
- Work environment.
- Inspector's office space (per contract).



## **Build Schedule**

The bus manufacturer's contract administrator shall supply a fleet build production schedule based on the dates in the Notice to Proceed, and a description of the manufacturer's schedule for plant operations.

The production schedule should contain specific milestone dates, such as the following:

- First vehicle on production line (date on which any work will begin).
- First vehicle off production line.
- First vehicle through manufacturer's quality assurance inspections.
- First vehicle shipped to the Agency.
- Last vehicle on production line.
- Last vehicle off production line.
- Last vehicle shipped to the Agency.

## **Plant Tour (if Meeting at OEM's Location)**

The Agency will review the entire process from start to finish and review the work completed at each line station, including quality control measures.

## **Prototype/Pilot Vehicle Production**

The Contractor shall conduct acceptance tests at its plant on each bus following completion of manufacture and before delivery to the Agency. These pre-delivery tests shall include visual and measured inspections, as well as testing the total bus operation. The tests shall be conducted and documented in accordance with written test plans approved by the Agency. The underfloor equipment shall be available for inspection by the resident inspectors, using a pit or bus hoist provided by the Contractor. A hoist, scaffold or elevated platform shall be provided by the Contractor to easily and safely inspect bus roofs. Delivery of each bus shall require written authorization of the primary resident inspector. Authorization forms for the release of each bus for delivery shall be provided by the Contractor. An executed copy of the authorization shall accompany the delivery of each bus.

Additional tests may be conducted at the Agency's discretion to ensure that the completed buses have attained the required quality and have met the requirements in "Section 6: Technical Specifications." The Agency may, prior to commencement of production, demand that the Contractor demonstrate compliance with any requirement in that section if there is evidence that prior tests have been invalidated by the Contractor's change of Supplier or change in manufacturing process. Such demonstration shall be by actual test, or by supplying a report of a previously performed test on similar or like components and configuration. Any additional testing shall be recorded on appropriate test forms provided by the Contractor and shall be conducted before acceptance of the bus.

The pre-delivery tests shall be scheduled and conducted with 30 days' notice so that they may be witnessed by the resident inspectors, who may accept or reject the results of the tests. The results of pre-delivery tests, and any other tests, shall be filed with the assembly inspection records for each bus.

## **Visual and Measured Inspections**

Visual and measured inspections shall be conducted with the bus in a static condition. The purpose of the inspection testing includes verification of overall dimension and weight requirements, that required components are included and are ready for operation, and that components and subsystems designed to operate with the bus in a static condition do function as designed.

## **Total Bus Operation**

Total bus operation shall be evaluated during road tests. The purpose of the road tests is to observe and verify the operation of the bus as a system and to verify the functional operation of the subsystems that can be operated only while the bus is in motion.

Each bus shall be driven for a minimum of 15 miles during the road tests. If requested, computerized diagnostic printouts showing the performance of each bus shall be produced and provided to the Agency. Observed defects shall be recorded on the test forms. The bus shall be retested when defects are corrected and adjustments are made. This process shall continue until defects or required adjustments are no longer detected.

## **Post-Delivery Tests**

The Agency shall conduct acceptance tests on each delivered bus. These tests shall be completed within 15 days after bus delivery and shall be conducted in accordance with the Agency's written test plans. The purpose of these tests is to identify defects that have become apparent between the time of bus release and delivery to the Agency. The post-delivery tests shall include visual inspection and bus operations. No post-delivery test shall apply new criteria that are different from criteria applied in a pre-delivery test.

Buses that fail to pass the post-delivery tests are subject to non-acceptance. The Agency shall record details of all defects on the appropriate test forms and shall notify the Contractor of acceptance or non-acceptance of each bus, after completion of the tests. The defects detected during these tests shall be repaired according to procedures defined in the contract.

## **Prototype/Pilot Vehicle Acceptance**

In order to assess the Contractor's compliance with the Technical Specifications, the Agency and the Contractor shall, at the Pre-Production Meeting, jointly develop a Configuration and Performance Review document for review of the pilot vehicle. This document shall become part of the official record of the Pre-Production Meeting.

Potential dimensional/performance tests that may be included in the Configuration and Performance Review include the following:

- Complete electrical system audit
- Dimensional requirements audit
- Seating capacity
- Water test
- Water runoff test
- Function test of systems/subsystems and components
- Sound/noise level tests
- Vehicle top speed
- Acceleration tests
- Brake stop tests
- Airflow tests
- PA function tests
- Air/brake system audit
- Individual axle weight
- Standee capacity
- Body deflection tests
- Silent alarm function test
- Interior lighting

- Exterior lighting
- Gradeability test
- Kneeling system function
- HVAC pull down/heat
- Speedometer
- Outside air infiltration (smoke)
- Wheelchair ramps
- Propulsion system performance qualification
  - This test shall be jointly conducted by the Contractor and the propulsion system manufacturer (including but not limited to charge air cooler performance, air to boil test, loss of coolant, fuel system, electrical inputs and protection systems).
- Transmission performance qualifications
  - This test shall be jointly conducted by the Contractor and the transmission manufacturer (including but not limited to retarder operation, heat exchanger, interface with ABS and electrical inputs).

### **Buy America Audit**

A post-delivery Buy America audit is required for federally funded bus procurements (see 49 CFR Part 663 for additional information). The on-site resident inspectors are to monitor the production processes to verify compliance with final assembly requirements identified by the Buy America pre-award audit. This audit is to verify compliance with final assembly requirements and final documentation of Buy America compliance and must be completed prior to title transfer.

### **Resident Inspection Process for Serial Production**

At the discretion of the Agency, a decision is made to perform resident inspection using the Agency's personnel, a contract inspector, or a combination of both. The decision is based on factors such as the availability of personnel, knowledge/expertise in bus build project management, the size of the bus order, etc.

### **Inspector Responsibilities**

The resident inspection process for the serial production of the buses begins following the completion and acceptance of the prototype or pilot vehicle if required, or according to the serial bus production schedule. Resident inspectors should represent the Agency for all build-related issues (quality, conformance, etc.). Resident inspectors can also address contractual type issues but should only do so under the consult of the Agency's contracts administrator. Resident inspectors are sent to the manufacturer's facility according to a Resident Inspection Schedule. Typically, one or two inspectors arrive onsite at the manufacturing facility about one week prior to actual production to setup the resident inspection process and to begin preliminary quality assurance inspections for items such as power plant build-up and wire harness production, and to inspect incoming parts, fasteners, fluids, etc., that will be used in the production of the buses. During the serial production of the buses, the resident inspectors should monitor the production of each bus, verifying the quality of materials, components, sub-assemblies and manufacturing standards. In addition, the configuration of each vehicle should be audited using the vehicle manufacturer's Build Specification and other documents to ensure contract compliance and uniformity.

### **Inspector Rotation/Scheduling**

During the resident inspection phase, a single inspector or multiple inspectors could be used. If it is decided to use multiple inspectors, then the inspectors could be rotated on a biweekly to monthly basis as required. During the rotation of inspectors, a sufficient period of overlap should be provided to guarantee the consistency of the resident inspection process.

## **Resident Inspector Orientation**

A resident inspector orientation by the bus manufacturer should take place upon the arrival of the initial inspection team. The orientation should include expectations for the use of personal protective equipment (safety shoes, safety glasses, etc.), daily check-in and check-out requirements, lines of communication, use of production documents such as speed memos and line movement charts, inspector/production meetings, inspector office arrangements, and anything else pertinent to the inspection team's involvement during the build. Many of the above items should already be formalized during the Pre-Production Meeting.

## **Audits, Inspections and Tests**

The resident inspection process monitors the production of each vehicle. Inspection stations should be strategically placed to test or inspect components or other installations before they are concealed by subsequent fabrication or assembly operations. These locations typically are placed for the inspection of underbody structure, body framing, electrical panels and harnesses, air and hydraulic line routings, installation of insulation, power plant build-up and installation, rust inhibitor/undercoating application, floor installation, front suspension alignment, and other critical areas.

## **Vehicle Inspections**

Each bus is subjected to a series of inspections after the bus reaches the point of final completion on the assembly line. Typically, the vehicle manufacturer performs its own quality assurance inspections following assembly line completion before releasing each bus to the resident inspectors. The inspections for each vehicle are documented, signed off upon passing and included in the vehicle record.

These are the typical inspections performed on each bus by the resident inspectors:

- Water test inspection
- Road test inspection
- Interior inspection (including functionality)
- Hoist/undercarriage inspection
- Exterior inspection (including roof)
- Electrical inspection
- Wheelchair ramp/lift inspection

## **Water Test Inspection**

The water test inspection checks the integrity of the vehicle's body seams, window frame seals and other exterior component close-outs for their ability to keep rainwater, road splash, melting snow and slush, and other exterior water from entering the inside of the vehicle. The vehicle's interior is inspected for signs of moisture and water leaks. To perform the leak inspection, interior ceiling and side panels are removed, and access doors are opened. If any moisture or water is detected, then the source of the leak will be located and repaired by the manufacturer, and the vehicle will be tested again.

## **Road Test Inspection**

The road test inspection checks all the vehicle's systems and subsystems while the vehicle is in operation. Typically, the road test inspection is performed immediately following the water test inspection to reveal any standing water that may be present due to a leak, but was not noticed during the "static" water test. Objectionable vibrations, air leakage and other factors that affect ride quality are recorded and reported to the vehicle manufacturer for resolution. Vehicle stability, performance, braking and interlock systems, HVAC, and other critical areas are checked to ensure that the vehicle is complete and ready to provide safe and reliable service.

The following tests may be performed and recorded during the road test:

- Acceleration test
- Top speed test
- Gradability test
- Service brake test
- Parking brake test
- Turning effort test
- Turning radius test
- Shift quality
- Quality of retarder or regenerative braking action

During the road test, a vehicle may be taken to a weigh station to record the vehicle's front axle weight, rear axle weight and total vehicle (curb) weight.

### **Interior Inspection**

The interior inspection checks the fit and finish of the interior installations.

In addition, the inspection also verifies the installation and function of systems and subsystems according to the Build Specification. All systems and functions accessed from the interior are inspected for functionality, appearance and safety.

Examples of systems/functions inspected include the following:

- Interior and exterior lighting controls
- Front and rear door systems
- Flooring installation
- Passenger and operator's seat systems
- Wheelchair securement and ramp systems
- Fire suppression system
- Electrical installations (multiplex, tell-tale wiring, panels, etc.)
- Window systems and emergency escape portals
- Operator dash/side panel controls/indicators

### **Hoist/Undercarriage Inspection**

The hoist/undercarriage inspection checks the installation of components, wiring, air lines, presence of fluid leaks, etc., located under the vehicle. Typically, this inspection is performed following the road test. The vehicle is lifted onto a hoist or pulled over a pit for the inspection. Areas inspected are the front suspension, air bags, airline routings, electrical connections and routings, drivetrain components, linkages and any other system or component that may be prone to early failure due to inadequate installation techniques. All lines, cables, hoses, etc., are inspected for proper securement and protection to prevent rubbing, chafing or any other condition that could result in a failure. The engine/powerplant and HVAC compartments are also inspected during this time.

### **Exterior Inspection**

The exterior inspection checks the fit and finish of components installed on the exterior of the vehicle. Access panels are opened and accessories are inspected for proper installation. In addition, vehicle paint, graphics and proper decals are also inspected. Acceptable paint finish quality (orange peel, adhesion, etc.) should be agreed on with the vehicle manufacturer prior to production to ensure consistency of inspections.

## Electrical Inspection

The vehicle's main electrical panels and other subpanels are inspected for proper components, to include relays, fuses, modules, terminal strips, decals, etc. In addition, electrical harnesses are inspected for proper wiring and termination techniques, bulkhead protection, looming and other items that could result in future electrical failure. Onboard vehicle compartment schematics are verified for accuracy.

## Wheelchair Ramp Inspection

The wheelchair ramp assembly is inspected for proper installation and performance. Clearances critical to the operation of the ramp are verified, and the ramp's electrical systems are inspected to ensure appropriate wire routings and protection. The successful integration of the ramp assembly into the vehicle is verified, and the vehicle interlocks are checked during automatic and manual ramp operation.

## Audits

During serial production of the bus's quality assurance inspection, tests may be performed to ensure that the manufacturer's quality standards are being followed. These inspection audits could be on items such as torque wrench calibrations, proper techniques for fastener installations, proper use and type of adhesives, use of correct installation drawings on the production line, etc.

## Communications

The lines of communications, formal and informal, should be discussed and outlined in the Pre-Production Meeting. As previously discussed, resident inspectors should represent the Agency for all bus-build related issues (quality, conformance, etc.). Resident inspectors can relay communications addressing contractual type issues but should do so only under the consult of the Agency's contract administrator. Actual personnel contacts for the manufacturing facility should be established during resident inspector orientation. These contacts could include quality assurance, production, material handling, engineering and buy-off area personnel.

## Documentation

The following documents/reports are typically generated during the bus build process:

- Vehicle build specification
- Sales order
- Pre-Production Meeting notes
- Prototype and production correspondence (vehicle build file)
- Manufacturer's vehicle record (Warranty file)
  - Vehicle line documents
  - Serialization documents (Warranty file)
  - Alignment verification
  - Brake testing
  - HVAC testing and checkout
  - Manufacturer's QA checklist and signoff
  - Weight slip (prototype and Warranty file)
  - Prototype performance tests document (vehicle build file)
    - Acceleration Test
    - Top Speed Test
    - Gradeability Test
    - Interior Noise Test A – Stationary
    - Interior Noise Test B – Dynamic
    - Exterior Noise Test A – Pull Away

- Exterior Noise Test B – Pass-By
- Exterior Noise Test C – Curb Idle
- Turning Radius Test
- Turning Effort Test
- Parking Brake Test
- Service Brake Test
- Vehicle acceptance inspections—production (Warranty file)
  - Water Test Inspection Report
  - Road Test Inspection Report
  - Interior Inspection Report
  - Hoist/Undercarriage Inspection Report
  - Exterior Inspection Report
  - Electrical Inspection Report
  - Wheelchair Inspection Report
- Speed Memos (Warranty file)
- Agency Vehicle Inspection record(Warranty file)
- Release for delivery documentation (Warranty file)
- Post-Production Acceptance – Certificate of Acceptance(Accounting)
- Post-Delivery Inspection Report – (Fleet Management & Warranty files)

## Vehicle Release for Delivery

Upon satisfactory completion of all inspection, audit and test criteria, and resolution of any outstanding issues affecting the purchase of any or all buses, proper documentation (the Release for Delivery) is signed by the designated resident inspector authorizing the bus manufacturer to deliver the vehicle to the Agency’s facility, where it will undergo a post-delivery inspection process and final acceptance. The satisfactory sign-off of the Release for Delivery should complete the resident inspector’s duties for each bus. In final preparation for delivery, the bus manufacturer may request the resident inspector to do a final walk-through of the bus after it has been cleaned and prepped for shipping.

## Post-Delivery and Final Acceptance

The Agency shall conduct acceptance tests on each delivered bus. These tests shall be completed within 15 days after bus delivery and shall be conducted in accordance with the Agency’s written test plans. The purpose of these tests is to identify defects that have become apparent between the time of bus release and delivery to the Agency. The post-delivery tests shall include visual inspection, along with a verification of system(s) functionality and overall bus operations. No post-delivery test shall apply new criteria that are different from criteria applied in a pre-delivery test.

Buses that fail to pass the post-delivery tests are subject to non-acceptance. The Agency shall record details of all defects on the appropriate test forms and shall notify the Contractor of acceptance or non-acceptance of each bus within five days after completion of the tests. The defects detected during these tests shall be repaired according to procedures defined in the contract after non-acceptance.

## Certificate of Acceptance

- **Accepted**
- **Not accepted:** In the event that the bus does not meet all requirements for acceptance. The Agency must identify reasons for non-acceptance and work with the OEM to develop a timeline of addressing the problem for a satisfactory resolution and redelivery.
- **Conditional acceptance:** In the event that the bus does not meet all requirements for acceptance, the Agency may conditionally accept the bus and place it into revenue service pending receipt of Contractor furnished materials and/or labor necessary to address the identified issue(s).

## SECTION 9: FORMS AND CERTIFICATIONS

### CER 1. Proposer's Checklist

RFP: CARTA2019-04 40ft Electric Transit Bus

#### Package 1: Technical Proposal

- 1. Letter of Transmittal
- 2. Technical Proposal
- 3. Acknowledgement of Addenda
- 4. Form for Proposal Deviation
- 5. Vehicle Questionnaire
- 6. References and non-priced information (if provided by Proposer)
- 7. Engineering organization chart, engineering change control procedure, field modification process
- 8. Manufacturing facility plant layout, other contracts, staffing
- 9. Production schedule and other Contract commitments for the duration of this Contract.
- 10. Quality Assurance Program

#### Package 2: Price Proposal

- 1. Letter of Transmittal
- 2. Pricing Schedule (including option buses, spare parts package, engineering, manuals, training, special tools and test equipment)

#### Package 3: Qualifications Package

- 1. Pre-Award Evaluation Data Form
- 2. A copy of the three (3) most recent audited financial statements or a statement from the Proposer regarding how financial information may be reviewed by the Agency
- 3. Letter for insurance
- 4. Letter for performance bond (if applicable)
- 5. Letter of commitment for parental financial guarantee (if applicable)
- 6. Proposal Form

#### Package 4: Proprietary/Confidential Information

- 1. Proprietary/Confidential Information

There may be items in the first three packages that are included in Package 4 because they are considered to be proprietary/confidential information. When this occurs, the Proposer must note that fact in packages 1 through 3.





**CER 3. Acknowledgement of Addenda**

Failure to acknowledge receipt of all addenda may cause the Proposal to be considered nonresponsive to the Solicitation. Acknowledged receipt of each addendum must be clearly established and included with the Proposal.

- The undersigned acknowledges receipt of the following addenda to the documents:	
Addendum No.:	- Dated:
Addendum No.:	- Dated:
Addendum No.:	- Dated:
Addendum No.:	- Dated:
- Proposer:	
Name:	
Title:	
Phone:	
Street address:	
City, state, ZIP:	
- _____	
Authorized signature	Date

### CER 4. Contractor Service and Parts Support Data

- **Location of nearest Technical Service Representative to Agency**  
Name:  
Address:  
Telephone:  
Describe technical services readily available from said representative:
  
- **Location of nearest Parts Distribution Center to Agency:**
  - Name:
  - Address:
  - Telephone:
  - Describe the extent of parts available at said center:
  
- **Policy for delivery of parts and components to be purchased for service and maintenance:**
  - Regular method of shipment:
  - Cost to Agency:

**CER 5. Form for Proposal Deviation**

This form shall be completed for each condition, exception, reservation or understanding (i.e., Deviation) in the Proposal according to “Conditions, Exceptions, Reservations or Understandings.” One copy without any price/cost information is to be placed in the Technical Proposal as specified in “Technical Proposal Requirements,” and a separate copy with any price/cost information placed in the Price Proposal as specified in “Price Proposal Requirements.”

Charleston Area Regional Transportation Authority  
RFP: CARTA2019-04 40ft Electric Transit Bus

Deviation No.:	Contractor:	RFP section:	Page:
<b>Complete description of Deviation:</b>			
<b>Rationale (pros and cons):</b>			

**CER 6. Pricing Schedule**

Charleston Area Regional Transportation Authority  
RFP: CARTA2019-04 40ft Electric Transit Bus

	All prices are to be in United States dollars	
	– Unit Price	– Extension
<b>Qty 6 - 40ft Electric Transit Bus</b>		
<b>Depot Plug In Charging Stations</b>		
<b>On-Route Charging Stations</b>		
– Extended Warranty		
– Extended Warranty		
– Other		
– Other		
– Other		
– Sales tax (if applicable)	N/A	N/A
– Delivery charges		
<b>– TOTAL PROPOSED PRICE</b>		
– ADA equipment (included in above unit prices)		

– This form is to be completed and included in the Price Package.

## CER 7. Pre-Award Evaluation Data Form

**NOTE:** This form is to be completed and included in the Qualification Package. Attach additional pages if required.

Charleston Area Regional Transportation Authority  
RFP: CARTA2019-04 40ft Electric Transit Bus

<p><b>1. Name of firm:</b></p> <p><b>2. Address:</b></p> <p><b>3. <input type="checkbox"/> Individual <input type="checkbox"/> Partnership <input type="checkbox"/> Corporation <input type="checkbox"/> Joint Venture</b></p> <p><b>4. Date organized:</b> <b>State in which incorporated:</b></p> <p><b>5. Names of officers or partners:</b></p> <p>a. b. c. d. e.</p> <p><b>6. How long has your firm been in business under its present name?</b></p>
<p>7. Attach as <b>SCHEDULE ONE</b> a list of similar current contracts that demonstrates your available capacity, including the quantity and type of bus, name of contracting party, percentage completed and expected completion date.</p> <p>8. Attach as <b>SCHEDULE TWO</b> a list of at least three similar contracts that demonstrates your technical proficiency, each with the name of the contracting party and number and they type of buses completed within the last five years.</p> <p><b>9. Have you been terminated or defaulted, in the past five years, on any Contract you were awarded?</b> <input type="checkbox"/> Yes <input type="checkbox"/> No If yes, then attach as <b>SCHEDULE THREE</b> the full particulars regarding each occurrence.</p> <p>10. Attach as <b>SCHEDULE FOUR</b> Proposer's last three (3) financial statements prepared in accordance with generally accepted accounting principles of the jurisdiction in which the Proposer is located, and audited by an independent certified public accountant; or a statement from the Proposer regarding how financial information may be reviewed by the Agency (This may require execution of an acceptable non-disclosure agreement between the Agency and the Proposer.)</p> <p>11. Attach as <b>SCHEDULE FIVE</b> a list of all principal Subcontractors and the percentage and character of Work (Contract amount) that each will perform on this Contract.</p> <p>12. If the Contractor or Subcontractor is a joint venture, submit <b>PRE-AWARD EVALUATION DATA</b> forms for each member of the joint venture.</p>
<p>The above information is confidential and will not be divulged to any unauthorized personnel.</p>
<p>The undersigned certifies to the accuracy of all information: <b>Name and title:</b> <b>Company:</b></p> <p>_____</p> <p>Authorized signature <span style="float: right;">Date</span></p>

**CER 8. Federal Certifications**  
**CER 8.1 Buy America Certification**

This form is to be submitted with an offer exceeding the small purchase threshold for federal assistance programs, currently set at \$100,000.

**– Certificate of Compliance**

The Proposer hereby certifies that it will comply with the requirements of 49 USC Section 5323(j)(2)(C), Section 165(b)(3) of the Surface Transportation Assistance Act of 1982, as amended, and the regulations of 49 CFR 661.11:

**Name and title:**  
**Company:**

\_\_\_\_\_

Authorized signature Date

**Certificate of Non-Compliance**

The Proposer hereby certifies that it cannot comply with the requirements of 49 USC Section 5323(j)(2)(C) and Section 165(b)(3) of the Surface Transportation Assistance Act of 1982, as amended, but may qualify for an exception to the requirements consistent with 49 USC Sections 5323(j)(2)(B) or (j)(2)(D), Sections 165(b)(2) or (b)(4) of the Surface Transportation Assistance Act, as amended, and regulations in 49 CFR 661.7.

**Name and title:**  
**Company:**

\_\_\_\_\_

Authorized signature Date

**CER 8.2 Debarment and Suspension Certification for Prospective Contractor**

Primary covered transactions must be completed by Proposer for contract value over \$25,000.

Choose one alternative:

– The Proposer, \_\_\_\_\_ certifies to the best of its knowledge and belief that it and its principals:

1. Are not presently debarred, suspended, proposed for debarment, declared ineligible, or voluntarily excluded from covered transactions by any federal department or agency;
2. Have not within a three-year period preceding this Proposal been convicted of or had a civil judgment rendered against them for commission of fraud or a criminal offense in connection with obtaining, attempting to obtain, or performing a public (federal, state or local) transaction or Contract under a public transaction; violation of federal or state antitrust statutes or commission or embezzlement, theft, forgery, bribery, falsification or destruction of records, making false statements, or receiving stolen property;
3. Are not presently indicted for or otherwise criminally or civilly charged by a governmental entity (federal, state, or local) with commission of any of the offenses enumerated in Paragraph 2 of this certification; and
4. Have not within a three-year period preceding this Proposal had one or more public transactions (federal, state or local) terminated for cause or default.

**OR**

– The Proposer is unable to certify to all of the statements in this certification, and attaches its explanation to this certification. (In explanation, certify to those statements that can be certified to and explain those that cannot.)

The Proposer certifies or affirms the truthfulness and accuracy of the contents of the statements submitted on or with this certification and understands that the provisions of Title 31 USC § Sections 3801 are applicable thereto.

---

**Name:**

\_\_\_\_\_

Authorized signature Date



**CER 8.3 Debarment and Suspension Certification (Lower-Tier Covered Transaction)**

This form is to be submitted by each Subcontractor receiving an amount exceeding \$25,000.

<p>The prospective lower-tier participant (Proposer) certifies, by submission of this Proposal, that neither it nor its "principals" as defined at 49 CFR § 29.105(p) is presently debarred, suspended, proposed for debarment, declared ineligible, or voluntarily excluded from participation in this transaction by any federal department or agency.</p> <p>If the prospective Proposer is unable to certify to the statement above, it shall attach an explanation, and indicate that it has done so by placing an "X" in the following space: _____</p> <p><b>THE PROPOSER, _____, CERTIFIES OR AFFIRMS THE TRUTHFULNESS AND ACCURACY OF EACH STATEMENT OF ITS CERTIFICATION AND EXPLANATION, IF ANY. IN ADDITION, THE PROPOSER UNDERSTANDS AND AGREES THAT THE PROVISIONS OF 31 USC §§ 3801 ET SEQ. APPLY TO THIS CERTIFICATION AND EXPLANATION, IF ANY.</b></p>
<p><b>Name and title of the Proposer's authorized official:</b></p>    <hr/>
<p>Authorized signature _____ Date _____</p>

**CER 8.4 Non-Collusion Affidavit**

This affidavit is to be filled out and executed by the Proposer; if a corporation makes the bid, then by its properly executed agent. The name of the individual swearing to the affidavit should appear on the line marked "Name of Affiant." The affiant's capacity, when a partner or officer of a corporation, should be inserted on the line marked "Capacity." The representative of the Proposer should sign his or her individual name at the end, not a partnership or corporation name, and swear to this affidavit before a notary public, who must attach his or her seal.

State of _____, County of _____	
I, _____, being first duly sworn, do hereby state that (Name of Affiant)	
I am _____ of _____ (Capacity) (Name of Firm, Partnership or Corporation)	
whose business is _____	
and who resides at _____	
and that _____ (Give names of all persons, firms, or corporations interested in the bid)	
is/are the only person(s) with me in the profits of the herein contained Contract; that the Contract is made without any connection or interest in the profits thereof with any persons making any bid or Proposal for said Work; that the said Contract is on my part, in all respects, fair and without collusion or fraud, and also that no members of the Board of Trustees, head of any department or bureau, or employee therein, or any employee of the Authority, is directly or indirectly interested therein.	
_____ Signature of Affiant Date	
Sworn to before me this _____ day of _____, 20____.	- Seal
_____ Notary public My commission expires	

**CER 8.5 Lobbying Certification**

This form is to be submitted with an offer exceeding \$100,000.

The Proposer certifies, to the best its knowledge and belief, that:

- 1. No federal appropriated funds have been paid or will be paid, by or on behalf of the undersigned, to any person for influencing or attempting to influence an officer or employee of a federal department or agency, a member of the U.S. Congress, an officer or employee of the U.S. Congress, or an employee of a member of the U.S. Congress in connection with the awarding of any federal Contract, the making of any federal grant, the making of any federal loan, the entering into of any cooperative agreement, and the extension, continuation, renewal, amendment or modification thereof.
- 2. If any funds other than federal appropriated funds have been paid or will be paid to any person for making lobbying contacts to an officer or employee of any agency, a member of Congress, an officer or employee of Congress, or an employee of a member of Congress in connection with this federal Contract, grant, loan or cooperative agreement, the undersigned shall complete and submit Standard Form LLL, "Disclosure Form to Report Lobbying," in accordance with its instruction, as amended by "Government wide Guidance for New Restrictions on Lobbying," 61 Fed. Reg. 1413 (1/19/96).
- 3. The undersigned shall require that the language of this certification be included in the award documents for all sub awards at all tiers (including subcontracts, sub grants and contracts under grants, loans and cooperative agreements) and that all sub recipients shall certify and disclose accordingly. This certification is a material representation of fact upon which reliance was placed when this transaction was made or entered into. Submission of this certification is a prerequisite for making or entering into this transaction imposed by 31, USC § 1352 (as amended by the Lobbying Disclosure Act of 1995). Any person who fails to file the required certification shall be subject to a civil penalty of not less than \$10,000 and not more than \$100,000 for each such failure.

**THE PROPOSER, \_\_\_\_\_, CERTIFIES OR AFFIRMS THE TRUTHFULNESS AND ACCURACY OF EACH STATEMENT OF ITS CERTIFICATION AND DISCLOSURE, IF ANY. IN ADDITION, THE PROPOSER UNDERSTANDS AND AGREES THAT THE PROVISIONS OF 31 USC §§ 3801 ET SEQ. APPLY TO THIS CERTIFICATION AND DISCLOSURE, IF ANY.**

Name of the bidder or Proposer's authorized official: \_\_\_\_\_

Title: \_\_\_\_\_

Signature

Date

Per paragraph 2 of the included form Lobbying Certification, add Standard Form–LLL, "Disclosure Form to Report Lobbying," if applicable.

**CER 8.6 Certificate of Compliance with Bus Testing Requirement**

The undersigned certifies that the vehicle offered in this procurement complies and will, when delivered, comply with 49 USC § 5323(c) and FTA’s implementing regulation at 49 CFR Part 665 according to the indicated one of the following three alternatives.

Mark one and only one of the three blank spaces with an “X.”

- 1. \_\_\_\_\_ The buses offered herewith have been tested in accordance with 49 CFR Part 665 on \_\_\_\_\_ (date). If multiple buses are being proposed, provide additional bus testing information below or on attached sheet. The vehicles being sold should have the identical configuration and major components as the vehicle in the test report, which must be submitted with this Proposal. If the configuration or components are not identical, then the manufacturer shall provide with its Proposal a description of the change and the manufacturer’s basis for concluding that it is not a major change requiring additional testing. If multiple buses are being proposed, testing data on additional buses shall be listed on the bottom of this page.
  
- 2. \_\_\_\_\_ The manufacturer represents that the vehicle is “grandfathered” (has been used in mass transit service in the United States before October 1, 1988, and is currently being produced without a major change in configuration or components), and submits with this Proposal the name and address of the recipient of such a vehicle and the details of that vehicle’s configuration and major components.
  
- 3. \_\_\_\_\_ The vehicle is a new model and will be tested and the results will be submitted to the Agency prior to acceptance of the first bus.

The undersigned understands that misrepresenting the testing status of a vehicle acquired with federal financial assistance may subject the undersigned to civil penalties as outlined in the Department of Transportation’s regulation on Program Fraud Civil Remedies, 49 CFR Part 31. In addition, the undersigned understands that FTA may suspend or debar a manufacturer under the procedures in 49 CFR Part 29.

**Company name:**  
**Name and title of the Proposer’s authorized official:**

---

Authorized signature \_\_\_\_\_ Date \_\_\_\_\_

**CER 8.7 DBE Approval Certification**

I hereby certify that the Proposer has complied with the requirements of 49 CFR 26, Participation by Disadvantaged Business Enterprises in DOT Programs, and that its goals have not been disapproved by the Federal Transit Administration.

**Name and title of the Proposer’s authorized official:**

---

Authorized signature Date

**CER 8.8 Federal Motor Vehicle Safety Standards**

The Proposer and (if selected) Contractor shall submit (1) manufacturer’s FMVSS self-certification sticker information that the vehicle complies with relevant FMVSS or (2) manufacturer’s certified statement that the contracted buses will not be subject to FMVSS regulations.

**Company name:**  
**Name of signer:**  
**Title:**

---

Authorized signature Date

**CER 9. Other Certifications**  
**CER 9.1 Proposal Form**

**NOTE:** The following is an example of a Proposal form to be modified as appropriate by the Agency and included in the RFP.

Proposer shall complete the following form and include it in the price Proposal.

**PROPOSAL**

By execution below by a duly authorized representative(s) of the Proposer, the Proposer hereby offers to furnish equipment and services as specified in its Proposal submitted to CARTA in response to Request for Proposal No. CARTA2019-04 in its entirety.

Proposer: \_\_\_\_\_

Street address: \_\_\_\_\_

City, state, ZIP: \_\_\_\_\_

Name and title of Authorized Signer(s): \_\_\_\_\_

Name and title of Authorized Signer(s): \_\_\_\_\_

Phone: \_\_\_\_\_

\_\_\_\_\_  
Authorized signature

\_\_\_\_\_  
Date

\_\_\_\_\_  
Authorized signature

\_\_\_\_\_  
Date

**CER 9.2 Notice of Award**

By execution below, CARTA accepts Proposal as indicated above.

Procurement/Contracts Administrator:

---

---

Authorized signature

Date



## CER 9.3 Certification of Compliance with Standards, Certifications and Regulations

CER 9.3 identifies the specifications, standards, regulations, and references used within this RFP. This form must be completed and included in the Technical Proposal and requires an indication of the state of compliance and an opportunity for listing other pertinent references. Please indicate “compliance” as, full, partial or N/A (not applicable). If “partial” or “N/A,” please describe.

Standard	Title	Compliance	If “partial” or “N/A,” please describe
SAE J10	Automotive and Off-Highway Air Brake Reservoir Performance and Identification Requirements - Truck and Bus J10_201312		
SAE J211a	Instrumentation for Impact Test J211A_197112		
SAE J287	Driver Hand Control Reach J287_201603		
SAE J366	Exterior Sound Level for Heavy Trucks and Buses (STABILIZED Sep 2011) J366_201109		
SAE J382	Windshield Defrosting Systems Performance Requirements-- Trucks, Buses, and Multipurpose Vehicles (Cancelled Sep 2000) J382_200009		
SAE J534	Lubrication Fittings J534_201508		
SAE J537	Storage Batteries J537_201604		
SAE J541	Voltage Drop for Starting Motor Circuits (Cancelled Jul 2013) J541_201307		
SAE J587	License Plate Illumination Devices (Rear Registration Plate Illumination Devices) J587_201711		
SAE J593	Backup Lamp (Reversing Lamp) J593_201606		
SAE J673	Automotive Safety Glazing Materials J673_201506		
SAE J680	Location and Operation of Air Brake Controls in Motor Truck Cabs J680_201508		
SAE J686	Motor Vehicle License Plates (STABILIZED Jul 2012) J686_201207		
SAE J689	Curbstone Clearance, Approach, Departure, and Ramp Breakover Angles—Passenger Car and Light Truck (Cancelled Aug 2009) J689_200908		
SAE J833	Human Physical Dimensions		
SAE J844	Nonmetallic Air Brake System Tubing (STABILIZED Dec 2012) J844_201212		
SAE J941	Motor Vehicle Drivers' Eye Locations J941_201003		
SAE J994	Alarm—Backup—Electric Laboratory Performance Testing J994_201409		
SAE J1050	Describing and Measuring the Driver's Field of View J1050_200902		

Standard	Title	Compliance	If "partial" or "N/A," please describe
SAE J1113	Electromagnetic Compatibility Measurement Procedures and Limits for Components of Vehicles, Boats (up to 15 m), and Machines (Except Aircraft) (16.6 Hz to 18 GHz) J1113/1_201810		
SAE J1127	Low Voltage Battery Cable J1127_201512		
SAE J1128	Low Voltage Primary Cable J1128_201512		
SAE J1149	Metallic Air Brake System Tubing and Pipe (STABILIZED Oct 2015) J1149_201510		
SAE J1292	Automobile and Motor Coach Wiring(STABILIZED Apr 2016) J1292_201604		
SAE J1308	Fan Guard for Off-Road Machines J1308_201312		
SAE J1455	Recommended Environmental Practices for Electronic Equipment Design in Heavy-Duty Vehicle Applications J1455_201703		
SAE J1587	Electronic Data Interchange Between Microcomputer Systems in Heavy-Duty Vehicle Applications (STABILIZED Jan 2013) J1587_201301		
SAE J1654	Unshielded High Voltage Primary Cable J1654_201609		
SAE J1708	Serial Data Communications Between Microcomputer Systems in Heavy-Duty Vehicle Applications (STABILIZED Sep 2016) J1708_201609		
SAE J1763	A Conceptual Its Architecture: An Atis Perspective (Cancelled May 2003) J1763_200304		
SAE J1772	SAE Electric Vehicle and Plug in Hybrid Electric Vehicle Conductive Charge Coupler J1772_201710		
SAE J1939	Serial Control and Communications Heavy Duty Vehicle Network - Top Level Document J1939_201808		
SAE J1986	Balance Weight and Rim Flange Design Specifications, Test Procedures, and Performance Recommendations J1986_201603		
SAE J1995	Engine Power Test Code - Spark Ignition and Compression Ignition - Gross Power and Torque Rating J1995_201401		
SAE J2344	Guidelines for Electric Vehicle Safety J2344_201003		
SAE J2402	Road Vehicles—Symbols for Controls, Indicators, and Tell-tales J2402_201001		
SAE J2464	Electric and Hybrid Electric Vehicle Rechargeable Energy Storage System (RESS) Safety and Abuse Testing J2464_200911		
SAE J2711	Recommended Practice for Measuring Fuel Economy and Emissions of Hybrid-Electric and Conventional Heavy-Duty Vehicles(STABILIZED Jul 2018) J2711_201807		
SAE J2910	Recommended Practice for the Design and Test of Hybrid Electric and Electric Trucks and Buses for Electrical Safety J2910_201404		
SAE J3068	Electric Vehicle Power Transfer System Using a Three-Phase Capable Coupler J3068_201804		

Standard	Title	Compliance	If "partial" or "N/A," please describe
FMVSS 105	Hydraulic and Electric Brake Systems		
FMVSS 121	Air Brake Systems		
FMVSS 207	Seating Systems		
FMVSS 210	Seat Belt Assembly Anchorages		
FMVSS 217	Bus Emergency Exits and Window Retention and Release		
FMVSS 301	Fuel System Integrity		
FMVSS 302	Flammability of Interior Materials		
FMVSS 403	Platform Lift Systems for Motor Vehicles		
FMVSS 404	Platform Lift Installations in Motor Vehicles		
ANSI/IAS NGV2 (1998)	Basic Requirements for Compressed Natural Gas Vehicle (NGV) Fuel Containers		
ANSI/IAS PRD1 (1998)	Pressure Relief Devices For Natural Gas Vehicle (NGV) Fuel Containers		
ANSI Z26.1	Safety Glazing Materials for Glazing Motor Vehicles and Motor Vehicle Equipment Operating on Land Highways - Safety Standard		
ANSI/ASHR AE 52.1	Method of Testing General Ventilation Air-Cleaning Devices for Removal Efficiency by Particle Size		
ASTM A240	Standard Specification for Chromium and Chromium-Nickel Stainless Steel Plate, Sheet, and Strip for Pressure Vessels and for General Applications		
ASTM A269	Standard Specification for Seamless and Welded Austenitic Stainless Steel Tubing for General Service		
ASTM B117	Standard Practice for Operating Salt Spray (Fog) Apparatus		
ASTM D1003	Standard Test Method for Haze and Luminous Transmittance of Transparent Plastics		
ASTM D4541-85	Standard Test Method for Pull-Off Strength of Coatings Using Portable Adhesion Testers		
ASTM E162-90	Standard Test Method for Surface Flammability of Materials Using a Radiant Heat Energy Source		
ASTM E424	Standard Test Methods for Solar Energy Transmittance and Reflectance (Terrestrial) of Sheet Materials		
ECE R100 Rev 2	Uniform provisions concerning the approval of vehicles with regard to specific requirements for the electric power train		
FTA Docket 90A	Recommended Fire Safety Practices for Transit Bus and Van Materials Selection		
CGA C-6.4	Methods for External Visual Inspection of Natural Gas Vehicle (NGV) Fuel Containers and Their Installation		
NGV-3.1/ CGA-12.3	Fuel system components for compressed natural gas powered vehicles		
CARB 2292.5	Specifications for Compressed Natural Gas		

Standard	Title	Compliance	If “partial” or “N/A,” please describe
UL 935	Standard for Fluorescent-Lamp Ballasts		
ISO 5128	Acoustics – Measurement of noise inside motor vehicles		
ISO 26262	Road Vehicles – Functional Safety		
NFPA-52	Vehicular Natural Gas Fuel Systems Code		
PS 1-95	Construction and Industrial Plywood		
UN/DOT 38.3	UN Transportation Testing for Lithium Batteries		
UNECE Council Directive 95/54(R10)	Adapting to technical progress Council Directive 72/245/EEC on the approximation of the laws of the Member States relating to the suppression of radio interference produced by spark-ignition engines fitted to motor vehicles and amending Directive 70/156/EEC on the approximation of the laws of the Member States relating to the type-approval of motor vehicles and their trailers		

### CER 10. Vehicle Technical Information

This form must be completed and included in the Technical Proposal.

**GENERAL DATA SHEET**  
40ft Electric Transit Bus

<b>Bus manufacturer:</b>	
Bus model:	
<b>Understructure manufacturer:</b>	
Model number:	

**Basic Body Construction**

Type:	
<b>Tubing or frame member thickness and dimensions</b>	
Overstructure	
Understructure	
<b>Skin thickness and material</b>	
Roof	
Sidewall	
Skirt panel	
Front end	
Rear end	

**Dimensions**

<b>Overall length</b>	Over bumpers	<input type="text"/>	ft	<input type="text"/>	in.
	Over body	<input type="text"/>	ft	<input type="text"/>	in.
<b>Overall width</b>	Over body excluding mirrors	<input type="text"/>	ft	<input type="text"/>	in.
	Over body including mirrors—driving position	<input type="text"/>	ft	<input type="text"/>	in.
	Over tires front axles	<input type="text"/>	ft	<input type="text"/>	in.
	Over tires center axle	<input type="text"/>	ft	<input type="text"/>	in.
	Over tires rear axles	<input type="text"/>	ft	<input type="text"/>	in.

<b>Overall height (maximum)</b>	<input type="text"/>	ft	<input type="text"/>	in.
<b>Overall height (main roof line)</b>	<input type="text"/>	ft	<input type="text"/>	in.

<b>Angle of approach</b>	<input type="text"/>	deg
<b>Breakover angle</b>	<input type="text"/>	deg
<b>Breakover angle (rear)</b>	<input type="text"/>	deg
<b>Angle of departure</b>	<input type="text"/>	deg

**Doorway Dimensions**

	Front	Rear
Width between door posts	<input type="text"/> in.	<input type="text"/> in.
Door width between panels	<input type="text"/> in.	<input type="text"/> in.
Clear door width	<input type="text"/> in.	<input type="text"/> in.
Doorway height	<input type="text"/> in.	<input type="text"/> in.
Knuckle clearance	<input type="text"/> in.	<input type="text"/> in.

Step height from ground measured at center of doorway

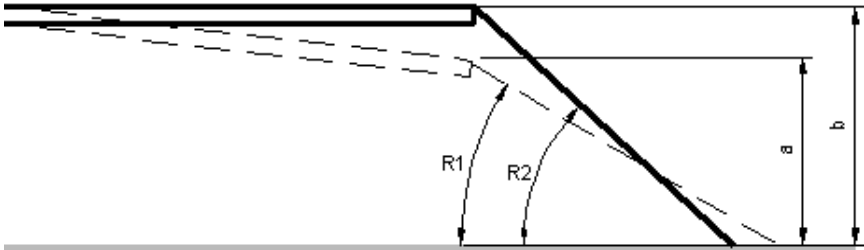

	Front doorway, empty	Ramp angle	Rear Doorway, empty
Kneeled	a. <input type="text"/> in.	R1 <input type="text"/> deg	a. <input type="text"/> in.
Unkneeled	b. <input type="text"/> in.	R2 <input type="text"/> deg	b. <input type="text"/> in.

**Interior head room (center of aisle)**

Front axle location	<input type="text"/> in.
Center axle location	<input type="text"/> in.
Rear axle location	<input type="text"/> in.

Aisle width between transverse seats  in.

**Floor height above ground (centerline of bus)**

At front door	<input type="text"/> in.
At front axle	<input type="text"/> in.
At drive axle	<input type="text"/> in.
At rear door	<input type="text"/> in.

**Minimum ground clearance (between bus and ground, with bus unkneeled)**

Excluding axles	<input type="text"/> in.
Including axles	<input type="text"/> in.

**Horizontal turning envelope** (see diagram below)

Outside body turning radius, TR0 (including bumper)  
 Front inner corner radius, TR1  
 Front wheel inner turning radius, TR2  
 Front wheel outer turning radius, TR3  
 Inside Body Turning Radius innermost point, TR4 (including bumper)

<input type="text"/>	ft	<input type="text"/>	in.
<input type="text"/>	ft	<input type="text"/>	in.
<input type="text"/>	ft	<input type="text"/>	in.
<input type="text"/>	ft	<input type="text"/>	in.
<input type="text"/>	ft	<input type="text"/>	in.

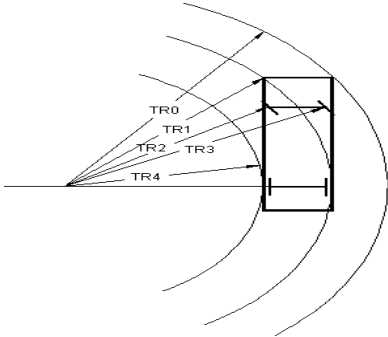

**Wheel base**

Front  in.  
 Rear  in.

**Overhang, centerline of axle over bumper**

Front  in.  
 Rear  in.

**Floor**

Interior length  ft  in.  
 Interior width (excluding coving)  ft  in.  
 Total standee area (approximately)  ft<sup>2</sup>  
 Minimum distance between wheelhouses:  
 Front  in.  
 Rear  in.  
 Center  in.  
 Maximum interior floor slope (from horizontal)  deg

**Passenger capacity provided**

Total maximum seating   
 Standee capacity   
 Minimum hip to knee room  in.  
 Minimum foot room  in.

**Weight**

	No. of people	Front axle			Center axle			Rear axle			Total bus
		Left	Right	Total	Left	Right	Total	Left	Right	Total	
Empty bus, full	<input type="text"/>	<input type="text"/>	<input type="text"/>	<input type="text"/>	<input type="text"/>	<input type="text"/>	<input type="text"/>	<input type="text"/>	<input type="text"/>	<input type="text"/>	<input type="text"/>

fuel and farebox											
Fully seated, full fuel and farebox											
Fully loaded standee and fully seated, full fuel and farebox											
Crush load (1.5x fully loaded)											
GVWR											
GAWR											

**Engine, main**

Manufacturer			
Type and weight rating			
Model number			
Bore		in.	
Stroke		in.	
Displacement		in. <sup>3</sup>	
Compression ratio			
Injector type and size			
Net SAE horsepower		hp at	
Net SAE torque		lb/ft at	
Crankcase oil capacity			
New engine, dry		gal	
New engine, wet		gal	
Turbocharger make and model			
Maximum speed, no load		RPM	
Maximum speed, full load		RPM	
Speed at idle		RPM	
Speed at fast idle		RPM	

**Engine information/graphs to be attached with this form:**

- Engine speed vs. road speed
- Torque vs. engine speed
- Horsepower vs. engine speed
- Fuel consumption vs. engine speed
- Vehicle speed vs. time (both loaded and unloaded)
- Vehicle speed vs. grade (both loaded and unloaded)
- Acceleration vs. time

**Traction Motor**

Manufacturer	
Model Number	



Type		
Max Power at Speed		kW @ rpm
Max Torque at Speed		N-m @ rpm
Continuous rated power		kW
Average efficiency		%
Max motor speed		rpm
Cooling Type		

Attach torque-speed curve and efficiency maps

Change of acceleration vs. time

**Hybrid drive or transmission**

Manufacturer				
Type				
Speeds				
Gear ratios	Forward:		Reverse:	
Shift speeds		mph		
1st-2nd		mph		
2nd-3rd		mph		
3rd-4th		mph		
4th-5th (if applicable)		mph		
5th-6th (if applicable)		mph		
Fuel capacity (including heat exchanger and filters)				

**Voltage regulator**

Manufacturer		
Model		

**Voltage equalizer**

Manufacturer		
Model		

**Alternator**

Manufacturer		
Type		
Model		
Output at idle		amps
Output at maximum speed		amps
Maximum warranted speed		rpm
Speed at idle (approximately)		rpm
Drive type		

**Auxiliary Inverter(s)**

Manufacturer		
--------------	--	--

Model Number	
Output Voltage	

**DC-DC Converter**

Manufacturer	
Model Number	
Output Voltage	

**Starter motor**

Manufacturer	
Type	
Model	

**Air compressor**

Manufacturer			
Type			
Rated capacity			CFM
Capacity at idle (approximately)			CFMs
Capacity at maximum speed (engine)			CFM
Maximum warranted speed			rpm
Speed idle			rpm
Drive type			
Governor:			
Cut-in pressure			psi
Cut-out pressure			psi

**Axles**

**First**

Manufacturer			
Type			
Model number			
Gross axle weight rating			lbs
Axle load			lbs

**Second**

Manufacturer			
Type			
Model number			
Gross axle weight rating			lbs
Axle load			lbs

**Third**

Manufacturer	
--------------	--

Type		
Model number		
Gross axle weight rating		lbs
Axle load		lbs
Axle ratio		

**Suspension system**

Manufacturer		
Type:	First:	
	Second:	
	Third:	
Springs:	First:	
	Second:	
	Third:	

**Joint**

Manufacturer		
Type		
Model number		

**Wheels and tires**

**Wheels**

Make		
Size		
Capacity		
Material		

**Tires**

Manufacturer		
Type		
Size		
Load range/air pressure		psi

**Steering, power**

**Pump**

Manufacturer and model number		
Type		
Relief pressure		psi

**Booster/gear box**

Manufacturer and model number		
Type		
Ratio		

Power steering fluid capacity	<input type="text"/>	gal
Maximum effort at steering wheel	<input type="text"/>	lbs (unloaded stationary coach on dry asphalt pavement)
Steering wheel diameter	<input type="text"/>	in.

**Brakes**

Make of fundamental brake system	<input type="text"/>		
Brake chambers vendor size and part number:	First:	<input type="text"/>	
	Second:	<input type="text"/>	
	Third:	<input type="text"/>	
Brake operation effort	<input type="text"/>		

**Slack adjuster's vendor's type and part numbers**

First:	Right:	<input type="text"/>
	Left:	<input type="text"/>
Second:	Right:	<input type="text"/>
	Left:	<input type="text"/>
Third:	Right:	<input type="text"/>
	Left:	<input type="text"/>
Length:	First take-up:	<input type="text"/>
	Second take-up:	<input type="text"/>
	Third take-up:	<input type="text"/>

**Brake drums/discs**

First:	Manufacturer	<input type="text"/>	
	Part number	<input type="text"/>	
	Diameter	<input type="text"/>	in.
Second:	Manufacturer	<input type="text"/>	
	Part number	<input type="text"/>	
	Diameter	<input type="text"/>	in.
Third:	Manufacturer	<input type="text"/>	
	Part number	<input type="text"/>	
	Diameter	<input type="text"/>	in.

Brake lining manufacturer	<input type="text"/>
Type	<input type="text"/>

**Brake lining identification**

First:	Forward	<input type="text"/>
	Reverse	<input type="text"/>
Second:	Forward	<input type="text"/>
	Reverse	<input type="text"/>
Third:	Forward	<input type="text"/>

Reverse

**Brake linings per shoe**

First	<input type="text"/>
Second	<input type="text"/>
Third	<input type="text"/>

**Brake lining widths**

First	<input type="text"/>	in.
Second	<input type="text"/>	in.
Third	<input type="text"/>	in.

**Brake lining lengths**

First	<input type="text"/>	in.
Second	<input type="text"/>	in.
Third	<input type="text"/>	in.

Brake lining thickness  in.

**Brake lining per axle**

First	<input type="text"/>	sq. in.
Second	<input type="text"/>	sq. in.
Third	<input type="text"/>	sq. in.

**Cooling system**

**Radiator/charge air cooler**

Manufacturer	<input type="text"/>		
Type	<input type="text"/>		
Model number	<input type="text"/>		
Number of tubes	<input type="text"/>		
Tubes outer diameter	<input type="text"/> in./	<input type="text"/> in.	
Fins per inch	<input type="text"/> fins		
Fin thickness	<input type="text"/> in.		
Total cooling and heating system capacity	<input type="text"/> gal		
Radiator fan speed control	<input type="text"/>		
Surge tank capacity	<input type="text"/> quarts		
Engine thermostat temperature setting: Initial opening (fully closed)	<input type="text"/>	°F	
	Fully open	<input type="text"/>	°F
Overheat alarm temperature sending unit setting	<input type="text"/>	°F	
Shutdown temperature setting	<input type="text"/>	°F	

**Air reservoir capacity**

Supply reservoir		in. <sup>3</sup>
Primary reservoir		in. <sup>3</sup>
Secondary reservoir		in. <sup>3</sup>
Packing reservoir		in. <sup>3</sup>
Accessory reservoir		in. <sup>3</sup>
Other reservoir type		in. <sup>3</sup>

**Heating, ventilation and air conditioning equipment**

Heating system capacity		BTU/hr
Electrical load at maximum heating capacity		kW
Air conditioning capacity		BTU
Electrical load at maximum cooling capacity		kW
Ventilating capacity		CFM

**Compressor**

Manufacturer			
Model			
Number of cylinders			
Drive ratio			
Maximum warranted speed			rpm
Operating speed			rpm (recommended)
Weight			lbs
Oil capacity	Dry		gal
	Wet		gal
Refrigerant:	Type		lbs

**Condenser**

Manufacturer		
Model		
Number of fins/in.		
Outer diameter of tube		in.
Fin thickness		in.

**Condenser fan**

Manufacturer		
Model		
Fan diameter		in.
Speed maximum		rpm
Flow rate (maximum)		CFM

**Receiver**

Manufacturer		
Model		
Capacity		lbs

**Condenser fan drive motors**

Manufacturer		
Model		
Type		
Horsepower		hp
Operating speed		rpm

**Evaporator fan drive motors**

Manufacturer		
Model		
Type		
Horsepower		hp
Operating speed		rpm

**Evaporator(s)**

Manufacturer		
Model		
Number of rows		
Number of fins/in.		
Outer diameter of tube		in.
Fin thickness		in.
Number of evaporators		

**Expansion valve**

Manufacturer		
Model		

**Filter-drier**

Manufacturer		
Model		

**Heater cores**

Manufacturer		
Model		
Capacity		Btu/hr
Number of rows		
Number of fins/in.		

Outer diameter of tube		in.
Fin thickness		in.
Number of heater cores		

**Floor heater blowers**

Front	
Rear	

**Controls**

Manufacturer	
Model	

**Driver's heater**

Manufacturer		
Model		
Capacity		Btu/hr

**Ventilation system**

Type	
------	--

**Coolant heater**

Make		
Model		
Capacity		Btu

**Interior lighting**

Manufacturer		
Type		
Number of fixtures		
Size of fixtures		
Power pack		

**Doors**

**Front**

Manufacturer of operating equipment	
Type of door	
Type of operating equipment	

**Rear**

Manufacturer of operating equipment	
Type of door	
Type of operating equipment	



**Passenger windows**

**Front**

Manufacturer			
Model			
Type			
Number:	Side		
	Rear		
Sizes:			
Glazing:	Type		
	Thickness		
	Color of tint		
	Light transmission		

**Mirrors**

	Size	Type	Manufacturer	Part no.	Model no.
Right side exterior					
Left side exterior					
Center rearview					
Front entrance area					
Upper-right corner					
Rear exit area					

**Seats**

**Passenger**

Manufacturer	
Model	
Type	

**Operator**

Manufacturer	
Model and part number	
Type	

**Paint**

Manufacturer	
Type	

**Wheelchair ramp equipment**

Manufacturer		
Model number		
Capacity		lbs

Width of platform		in.	
Length of platform		in.	
System fluid capacity		quarts	
Type of fluid used			
Operating hydraulic pressure		psi	
Hydraulic cylinders:	Size		
	Number		

**Wheelchair securement equipment**

Manufacturer	
Model number	

**Destination signs**

Manufacturer	
Type	

**Character length**

Front destination		in.	
Front route		in.	
Curbside destination		in.	
Rear route		in.	

**Character height**

Front destination		in.	
Front route		in.	
Curbside destination		in.	
Rear route		in.	

**Number of characters**

Front destination			
Front route			
Curbside destination			
Rear route			

**Message width**

Front destination		in.	
Front route		in.	
Curbside destination		in.	
Rear route		in.	

**Electrical**

**Multiplex system**

Manufacturer	
--------------	--

Model number

**Energy Storage**

Low Voltage

Manufacturer	
Model number	
Type	
Cold cranking amps	

High Voltage

Type/chemistry	
Manufacturer (cell)	
Model (cell)	
Nominal cell voltage	
Minimum cell voltage	
Maximum cell voltage	
Cell capacity (Ah)	
Manufacturer/supplier (pack or smallest removable unit)	
Model name (pack or smallest removable unit)	

Weight of pack (smallest removable unit)		lbs
Gross energy capacity of each pack (smallest removable unit)		kWh
Total number of packs in ESS		
Gross energy capacity of ESS when new		kWh
Usable energy capacity of ESS when new		kWh
Gross energy capacity of ESS at warrantable end of life		kWh
Usable energy capacity of ESS at warrantable end of life		kWh
Nominal voltage of ESS		V
Minimum allowable operating SoC		%
Maximum allowable operating SoC		%
Tested cycle until warrantable end of life		
Average ESS operating efficiency		%
Operating temperature range		°F

Energy storage cooling system		
Manufacturer		
Model number		
Type (e.g., forced air, liquid)		
Average power consumption		kW
Max power consumption		kW
Battery management system		
Manufacturer		
Model number		

**Charging Compatibility**

Charger inlet type	
Charging standards/compatibility	

**Batteries**

Manufacturer	
Model number	
Type	

**Communication system**

**GPS**

Manufacturer	
Model number	

**PA system**

	Manufacturer	Model number	Number
Amplifier			
Microphone			
Internal speakers			
External speaker			

**Energy storage (hybrid drive)**

Type		
Number of cells		V
Battery pack voltage		V
Weight		lbs

**Security camera system**

Manufacturer		
Model number		
Number of cameras		
Storage capacity		

**Bike racks**

Manufacturer	
Model number	

**Fire detection system**

Manufacturer		
Model number		
Fire detectors		
Type (thermal or optical)		

Number of detectors

**Automatic voice annunciator system**

Manufacturer   
Model and part number

**Annunciator LED sign**

Number of signs   
Housing dimensions   
Character length  in.  
Character height  in.  
Character width  in.

**GPS antenna**

Manufacturer   
Model and part number

**Automatic passenger counter**

Manufacturer   
Model and part number a.   
b.   
c.   
Sensor type

**Real-time bus arrival prediction system**

	Manufacturer	Model number
Router	Cradlepoint	IBR900
Cellular modem		
Charge protection		

**Electronic tire pressure monitoring system**

Manufacturer   
Model number

**Electronic brake stroke/wear indicator system**

Manufacturer   
Model number

## SECTION 10: APPENDIXES

### Appendix A: Guidelines for Calculating Liquidated Damages

#### Calculation of Liquidated Damages

Prior to its Solicitation, the Agency should document and file for the record its derivation of the amount of liquidated damage that is entered in “Liquidated Damages for Late Delivery of the Bus.” The following identifies some suggested areas for consideration by which an Agency may be damaged if buses are not delivered as contracted.

For determining amounts for liquidated damages, the following guidance is provided:

1. The liquidated damage amount must not be punitive but shall be based upon damages that the Agency would incur as a result of the delay.
2. The liquidated damage amount must be calculated on the basis of damages that the Agency would incur and be substantiated by experience data.
3. A definition of days and any exempted days for delay should be included.

#### Cost to Retain Old Fleet

If the purpose of the procurement is to replace older buses that are being retired, there can be two areas of damage that are additive: extra cost of maintenance and cost of purchasing or renting additional buses to meet fleet availability requirements.

1. **Extra cost of maintenance.** The *difference* in maintenance costs, old buses minus new ones, is a realistic damage, assuming that older buses will be continued in service for the duration and not replaced with alternative leased buses.
2. **Cost to obtain additional buses to meet fleet availability.** Reliability of the older buses is not expected to be as good as for new ones, and they can be expected to be out of service for maintenance or repair for longer periods than new ones. Therefore, additional buses may be needed to ensure that required service on routes is met.

#### Cost to Obtain Alternative Fleet

The damage may be attributed to requirements to obtain an alternative fleet for the duration of the delay. Such may be precipitated because a sales agreement on the old buses being replaced is expected to have been executed prior to the Contract delivery date for new buses or because the new buses are needed for new or expanded services.

1. **Cost to replace old buses being sold.** This approach is an alternative to the cost of retaining the old fleet of (1) above. It is suggested that the liquidated damage be the lower of this alternative and that of (1).
2. **Cost to meet requirements for new or expanded service.** Under this approach, the liquidated damage would simply be the daily costs of the alternative fleet as calculated above.

#### Increased Contract Administrative Costs

Delays in delivery will increase the period that the Contract must be administered and possibly increase the effort or waste the effort of either in-house staff or consultants for in-plant inspection and to assist in taking delivery and acceptance.

1. **Increased Contract period.** The amount of the damage can be calculated as the average daily cost of Contract administration, apart from any technical services.

2. **Increased technical services.** Technical services for in-plant inspection and to assist in taking delivery and acceptance will have been budgeted consistent with the Contract schedule. The extra budget for these services could be determined as a daily rate.

### **Fines**

Damages may include fines for which a court has already imposed or can be expected to be imposed on the Procuring Authority not meeting required emission (noise or air quality) reductions or features mandated by the Americans with Disabilities Act. Include this element only if the Agency can prove its vulnerability for such fines and a purpose of the procurement is to comply with such laws or ordinances.

### **Fuel Consumption**

If the new buses are expected to consume less fuel per passenger capacity, then the difference in fuel consumption costs per day may be included.

## Appendix B: Guidelines for Calculating Early Delivery Incentives

Any provision of incentive payments for early delivery should be made on the basis of savings that may be reasonably expected to accrue to the Agency. Prior to its Solicitation, the Agency should document and file for the record its derivation of the amount of any incentive that would be entered in the option provided in “Liquidated Damages for Late Delivery of the Bus.” It is suggested that any savings be shared between the Contractor and the Agency on the basis of some predetermined ratio, not exceeding an amount approximately that of the anticipated profit under the Contract. The following provides suggested areas in which an Agency may accrue savings for early delivery.

### Savings to Retire Old Fleet Early

If the purpose of the procurement is to replace older buses that are being retired, there can be savings in maintenance costs. The *difference* in maintenance costs, old buses minus new ones, could be a savings if the old fleet can be retired early.

### Decreased Contract Administrative Costs

Early delivery can decrease the period that the Contract must be administered. The amount of savings can be calculated as the average daily cost of Contract administration, apart from any technical services.

### Fines

If the Agency is being fined or can be expected to be imposed for failure to meet court-mandated emissions standards or requirements of the Americans with Disabilities Act, and early delivery reduces any such fines, savings will accrue. This element should be included *only* if the Agency can prove its vulnerability to such fines and a purpose of the procurement is to comply with such laws or ordinances.

### Fuel Consumption

If the new buses are expected to consume less fuel per passenger capacity, then the *difference* in fuel consumption costs per day may be included as a savings if the old fleet can in fact be replaced by the early delivered fleet.



## Appendix C: Examples of Evaluation Criteria

### EXAMPLE 1: EVALUATION OF PROPOSALS AND SELECTION PROCESS

#### A. Evaluation/Selection Committee

An Evaluation/Selection Committee (Committee), which may include Agency staff, consortium members, and possibly one or more outside experts, will review and screen the Proposals submitted according to the pre-established criteria as set forth below.

#### B. Technical Evaluation Criteria(maximum of 80 points)

Proposals will be evaluated using the following principal selection criteria:

1. **Product design and performance (0–30 points):**The information provided by the Proposer in its technical submittal relating to the buses to be provided will be utilized to evaluate the Proposal in relation to this factor. Vehicle construction and system design, as well as documented reliability, may be used in this evaluation, as well as other design and performance elements of the components that comprise those systems. At a minimum, test results, safety and maintenance factors, and cost of normal operation for the bus design and system components proposed, may be considered in determining a final value for this factor.
2. **Proposer’s reputation and performance (0–30 points):**The Committee will consider the capability and reputation of the Proposer as presented in the Proposal or as is determined by review of information available from references or other resources. The evaluation may look at the Proposer’s overall organizational and financial capabilities and consider key components such as organizational reporting structure, quality control, quality assurance, research and development, technical, training and parts support, response time, product capabilities, ability to furnish multiple bus configurations, bonding capacity, and financial history, as well as other considerations, in reaching a final point determination. The committee may also look at judgments, liens, Fleet Defect history, warranty claims and the steps that the manufacturer took to resolve these concerns in assessing the overall reputation of the manufacturer.
3. **Delivery schedule (0–20 points):**The Committee will review the proposed delivery schedule for the Agency’s minimum purchase of coaches. Delivery schedules that fulfill the delivery requirements, with evidence that the schedule can be accomplished, may receive higher points for this category.

#### C. Cost Proposal Evaluation (maximum of 20 points)

As described below, the proposed cost as submitted by the Proposer on the Agency’s form will be assigned a maximum of 20 points. The Contractor is *required* to use the Agency’s form, without alteration, for submittal of its cost Proposal. *Please DO NOT use your own forms.*

The cost will be evaluated in the following manner:

1. **Cost Proposal Criteria (0–20 points)**
  - a. The Cost Proposal criteria will be based on Line 3.C. of Appendix B as noted in Section 8.B.6, “Sum of Total Base Offer per Bus.”
  - b. The lowest average Cost Proposal will receive 20 points. Every other Proposal previously found to be in the Competitive Range will be given points proportionately in relation to the lowest price. This point total will be calculated by dividing the lowest price by the total price of the Proposal being evaluated and the result multiplied by the maximum weight for price (20 points) to arrive at a Cost Proposal score.

The application of the above formula will result in a uniform assignment of points relative to the criterion of price.

#### **D. Evaluation Methodology**

The maximum number of points achievable in each of the aforementioned areas is as follows:

- **Product design and performance:**0–30 points
- **Manufacturer’s reputation and performance:**0–30 points
- **Delivery schedule:**0–20 points
- **Cost proposal:**0–20 points

**TOTAL POSSIBLE POINTS: 100**

The Agency may require clarifications or oral interviews with Proposers. Discussions may also be held with Proposers to determine acceptability of proposed Deviations and/or to address deficiencies and weaknesses of the Proposal. See “Agency Rights” for additional information.

#### **Certifications**

The certifications will be reviewed for proper execution and responsiveness.

#### **Type of Contract to be Awarded**

The Agency intends to award a fixed-price Contract per unit for six (6) vehicles. The services of the Contractor will be based on the scope of Work as outlined in “Section 1: Description of Work.”

#### **Period for Acceptance**

The Proposal shall be valid for a minimum of 180 calendar days from the date stipulated in the RFP for receipt of Proposals. If this offer is accepted within that time period, the Proposer agrees to furnish all services and items as stipulated in the RFP and in any accompanying amendments.

## References

SAE #	Title	Date Published
J10	Methods of Test for Paints - Part J10: Determination of Deposition Efficiency of Coating Powders	Sep 15, 1998
J211	Instrumentation for Impact Test—Part 2: Photographic Instrumentation	May 1, 2001
J287	Driver Hand Control Reach	Feb 1, 2007
J366	Exterior Sound Level for Heavy Trucks and Buses	Feb 1, 1987
J382	Windshield Defrosting Systems Performance Requirements - Trucks, Buses, and Multipurpose Vehicles.	Jan 1, 1994
J534	Lubrication Fittings	May 1, 2008
J537	Storage Batteries	Sep 1, 2000
J541	Voltage Drop for Starting Motor Circuits	Oct 1, 1996
J587	License Plate Illumination Devices (Rear Registration Plate Illumination Devices)	Sep 1, 2003
J593	Backup Lamps (Reversing Lamps)	Sep 1, 2005
J673	Automotive Safety Glasses	Oct 1, 2005
J680	Location and Operation of Instruments and Controls in Motor Truck Cabs, Recommended Practice	Sep 1, 1988
J686	Motor Vehicle License Plates	Oct 1, 1999
J689	Curbstone Clearance, Approach, Departure, and Ramp Breakover Angles—Passenger Car and Light Truck	Aug 1, 2009
J833	Human Physical Dimensions	May 1, 2003
J844	Nonmetallic Air Brake System Tubing	Nov 1, 2004
J941	Motor Vehicle Drivers' Eye Locations	Mar 1, 2010
J994	Alarm—Backup—Electric Laboratory Performance Testing	Mar 1, 2009
J1050	Describing and Measuring the Driver's Field of View	Jan 1, 2003
J1113	Electromagnetic Compatibility Component Test Procedure Part 42, Conducted Transient Emissions	Oct 1, 2006
J1127	Low Voltage Battery Cable	Mar 1, 2010
J1128	Low Voltage Primary Cable	Dec 1, 2005
J1149	Metallic Air Brake System Tubing and Pipe	Aug 1, 2007
J1292	Automobile and Motor Coach Wiring	Jan 1, 2008
J1455	Recommended Environmental Practices for Electronic Equipment Design in Heavy-Duty Vehicle Applications	Jun 1, 2006
J1587	Joint SAE/TMC Electronic Data Interchange between Microcomputer Systems in Heavy-Duty Vehicle Applications, Recommended Practice	Jan 1, 1996
J1708	Serial Data Communications Between Microcomputer Systems in Heavy-Duty Vehicle Applications	Oct 1, 2008
J1986	Balance Weight and Rim Flange Design Specifications, Test Procedures, and Performance Recommendations	Jan 1, 2006
J1939	Data Link Layer	Dec 1, 2006
J1995	Engine Power Test Code - Spark Ignition and Compression Ignition - Gross Power Rating, Standard;	Jun 1, 1990
J2402	Road Vehicles—Symbols for Controls, Indicators, and Tell-tales	Jan 1, 2010
J2711	Recommended Practice for Measuring Fuel Economy and Emissions of Hybrid-Electric and Conventional Heavy-Duty Vehicles	Sept 1, 2002

## Abbreviation and Acronyms

<b>A/C</b>	air conditioning
<b>ABS</b>	antilock braking system
<b>AC</b>	alternating current
<b>ACQ</b>	alkaline copper quaternary
<b>ADA</b>	Americans with Disabilities Act
<b>ADB</b>	advanced design bus
<b>Ah</b>	amp hour
<b>ALR</b>	auto-locking retractor
<b>APA</b>	The Engineered Wood Association, formerly the American Plywood Association
<b>APC</b>	automatic passenger counter
<b>APTA</b>	American Public Transportation Association
<b>ASTM</b>	ASTM International, formerly the American Society for Testing and Materials
<b>ATC</b>	automatic traction control
<b>AVL</b>	automatic vehicle location
<b>AWG</b>	American Wire Gauge
<b>BAFO</b>	Best and Final Offer
<b>BMS</b>	Battery Management System
<b>BRT</b>	bus rapid transit
<b>CARB</b>	California Air Resources Board
<b>CCS</b>	climate control system
<b>CCTV</b>	closed-circuit television
<b>cfm</b>	cubic feet per minute
<b>CGA</b>	Compressed Gas Association
<b>CNG</b>	compressed natural gas
<b>dB</b>	decibel
<b>DBE</b>	disadvantaged business enterprise
<b>DC</b>	direct current
<b>DDU</b>	driver display unit
<b>DEF</b>	diesel exhaust fluid
<b>DOT</b>	Department of Transportation
<b>DPF</b>	diesel particulate filter
<b>EDR</b>	event data recorder
<b>ECM</b>	Engine Control and Monitoring
<b>ECS</b>	emission control system
<b>ELR</b>	emergency locking retractor
<b>EMI</b>	electromagnetic interference
<b>EPA</b>	Environmental Protection Agency
<b>EOL</b>	end of life
<b>ESS</b>	energy storage system
<b>EVSE</b>	electric vehicle supply equipment
<b>fc</b>	foot-candle
<b>FEA</b>	Finite Element Analysis
<b>FEMA</b>	failure mode effects analysis
<b>FMCSA</b>	Federal Motor Carrier Safety Administration
<b>FMVSS</b>	Federal Motor Vehicle Safety Standards
<b>FTA</b>	Federal Transit Administration
<b>GAWR</b>	gross axle weight rated
<b>GPS</b>	global positioning system
<b>GVW</b>	gross vehicle weight

<b>GVWR</b>	gross vehicle weight rated
<b>H-point</b>	hip-point
<b>HDS</b>	hybrid drive system
<b>HMI</b>	human-machine interface
<b>HSC</b>	hybrid system controller
<b>HV</b>	high voltage
<b>HVAC</b>	heating, ventilation and air conditioning
<b>I/O</b>	input/output
<b>IEEE</b>	Institute of Electrical and Electronics Engineers
<b>inHg</b>	inches of mercury
<b>ISO</b>	International Standards Organization
<b>kJ</b>	kilojoule
<b>LEL</b>	LED emergency light
<b>LFL</b>	lower flammability limit
<b>LV</b>	low voltage
<b>mA</b>	milliampere
<b>MDT</b>	mobile data terminal
<b>MPa</b>	mega-Pascal
<b>NC</b>	normally closed
<b>NFPA</b>	National Fire Protection Association
<b>NGV</b>	natural gas vehicle
<b>NOx</b>	nitrogen oxide
<b>NO</b>	normally open
<b>NTP</b>	notice to proceed
<b>OEM</b>	original equipment manufacturer
<b>OSI</b>	Open Systems Interconnect
<b>PA</b>	public address
<b>PMO</b>	project management oversight
<b>PPV</b>	price per vehicle
<b>PRD</b>	pressure relief device
<b>psi</b>	pounds per square inch
<b>RF</b>	radio frequency
<b>RFI</b>	radio frequency interference
<b>RTC</b>	real-time clock
<b>SAE</b>	SAE International, formerly the Society of Automotive Engineers
<b>scf</b>	standard cubic feet
<b>SLW</b>	seated load weight
<b>SoC</b>	state of charge
<b>UL</b>	Underwriters Laboratories
<b>UNECE</b>	United Nations Economic Commission for Europe
<b>UPS</b>	uninterruptable power supply
<b>USC</b>	United States Code
<b>USCA</b>	United States Code Annotated
<b>V DC</b>	volts of direct current
<b>WEOL</b>	warrantable end of life
<b>Wh</b>	watt-hours
<b>VIN</b>	vehicle information number
<b>ZEV</b>	zero-emission vehicle